



GPU SuperServer®
SYS-422GA-NRT

USER'S MANUAL

Revision 1.0 (MNL-2893)

The information in this User's Manual has been carefully reviewed and is believed to be accurate. The vendor assumes no responsibility for any inaccuracies that may be contained in this document, and makes no commitment to update or to keep current the information in this manual, or to notify any person or organization of the updates. Note: For the most up-to-date version of this manual, see our website at <https://www.supermicro.com>.

Super Micro Computer, Inc. ("Supermicro") reserves the right to make changes to the product described in this manual at any time and without notice. This product, including software and documentation, is the property of Supermicro and/or its licensors, and is supplied only under a license. Any use or reproduction of this product is not allowed, except as expressly permitted by the terms of said license.

IN NO EVENT WILL Super Micro Computer, Inc. BE LIABLE FOR DIRECT, INDIRECT, SPECIAL, INCIDENTAL, SPECULATIVE OR CONSEQUENTIAL DAMAGES ARISING FROM THE USE OR INABILITY TO USE THIS PRODUCT OR DOCUMENTATION, EVEN IF ADVISED OF THE POSSIBILITY OF SUCH DAMAGES. IN PARTICULAR, SUPER MICRO COMPUTER, INC. SHALL NOT HAVE LIABILITY FOR ANY HARDWARE, SOFTWARE, OR DATA STORED OR USED WITH THE PRODUCT, INCLUDING THE COSTS OF REPAIRING, REPLACING, INTEGRATING, INSTALLING OR RECOVERING SUCH HARDWARE, SOFTWARE, OR DATA.

Any disputes arising between manufacturer and customer shall be governed by the laws of Santa Clara County in the State of California, USA. The State of California, County of Santa Clara shall be the exclusive venue for the resolution of any such disputes. Supermicro's total liability for all claims will not exceed the price paid for the hardware product.

FCC Statement: This equipment has been tested and found to comply with the limits for a Class A or Class B digital device pursuant to Part 15 of the FCC Rules. These limits are designed to provide reasonable protection against harmful interference when the equipment is operated in industrial environment for Class A device or in residential environment for Class B device. This equipment generates, uses, and can radiate radio frequency energy and, if not installed and used in accordance with the manufacturer's instruction manual, may cause harmful interference with radio communications. Operation of this equipment in a residential area is likely to cause harmful interference, in which case you will be required to correct the interference at your own expense.

California Best Management Practices Regulations for Perchlorate Materials: This Perchlorate warning applies only to products containing CR (Manganese Dioxide) Lithium coin cells. "Perchlorate Material-special handling may apply. See <https://www.dtsc.ca.gov/hazardouswaste/perchlorate>".



WARNING: This product can expose you to chemicals including lead, known to the State of California to cause cancer and birth defects or other reproductive harm. For more information, go to <https://www.P65Warnings.ca.gov>.



AVERTISSEMENT : Ce produit peut vous exposer à des agents chimiques, y compris le plomb, identifié par l'État de Californie comme pouvant causer le cancer, des malformations congénitales ou d'autres troubles de la reproduction. Pour de plus amples informations, prière de consulter <https://www.P65Warnings.ca.gov>.

The products sold by Supermicro are not intended for and will not be used in life support systems, medical equipment, nuclear facilities or systems, aircraft, aircraft devices, aircraft/emergency communication devices or other critical systems whose failure to perform be reasonably expected to result in significant injury or loss of life or catastrophic property damage. Accordingly, Supermicro disclaims any and all liability, and should buyer use or sell such products for use in such ultra-hazardous applications, it does so entirely at its own risk. Furthermore, buyer agrees to fully indemnify, defend and hold Supermicro harmless for and against any and all claims, demands, actions, litigation, and proceedings of any kind arising out of or related to such ultra-hazardous use or sale.

Manual Revision 1.0

Release Date: March 30, 2026

Unless you request and receive written permission from Super Micro Computer, Inc., you may not copy any part of this document. Information in this document is subject to change without notice. Other products and companies referred to herein are trademarks or registered trademarks of their respective companies or mark holders.

Copyright © 2026 by Super Micro Computer, Inc.
All rights reserved.

Published in the United States of America

Preface

About This Manual

This manual is written for professional system integrators and PC technicians. It provides information for the installation and use of the SYS-422GA-NRT server. Installation and maintenance should be performed by certified service technicians only.

Notes

For your system to work properly, follow the links below to download all necessary drivers/utilities and the user's manual for your server.

- Supermicro product manuals: <https://www.supermicro.com/support/manuals>
- Product drivers and utilities: <https://www.supermicro.com/wdl>
- Product safety info: https://www.supermicro.com/about/policies/safety_information.cfm
- A secure data deletion tool designed to fully erase all data from storage devices can be found on our website:
https://www.supermicro.com/about/policies/disclaimer.cfm?url=/wdl/utility/Lot9_Secure_Data_Deletion_Utility
- Frequently Asked Questions: <https://www.supermicro.com/FAQ/index.php>
- If you still have questions after referring to our FAQs, contact our support team. Region-specific Technical Support email addresses can be found at: "[Contacting Supermicro](#)" on page 12
- If you have any feedback on Supermicro product manuals, contact our writing team at: Techwriterteam@supermicro.com

This manual may be periodically updated without notice. Check the Supermicro website for possible updates to the manual revision level.

Conventions Used in the Manual

Special attention should be given to the following symbols for proper installation and to prevent damage done to the components or injury to yourself.



Warning! Indicates important information given to prevent equipment/property damage or personal injury.



Warning! Indicates high voltage may be encountered while performing a procedure.



Warning! Indicates hazardous moving parts may be encountered while handling a fan or components near a fan.

Important: Important information given to ensure proper server installation or to relay safety precautions.

Note: Additional information given to differentiate various models or to provide information for proper server setup.

Contents

Contacting Supermicro	12
Chapter 1: Introduction	13
1.1 Overview	14
1.2 System Features	15
Front View	15
Control Panel	15
Rear View	17
1.3 System Architecture	19
Main Components	19
Motherboard Block Diagram	20
1.4 Motherboard Quick Reference	21
Motherboard Overview	21
Quick Reference	22
Chapter 2: Server Installation	25
2.1 Unpacking the System	26
2.2 Preparing for Setup	27
Choosing a Setup Location	27
Rack Precautions	27
System Precautions	27
Rack Mounting Considerations	28
Ambient Operating Temperature	29
Airflow	29
Mechanical Loading	29
Circuit Overloading	29
Reliable Ground	29
2.3 Installing the Rails	30
Identifying the Rails	30
Installing the Inner Rails onto the Chassis	31
Installing the Outer Rails onto the Rack	31
2.4 Installing the Chassis into the Rack	33
Removing the Chassis from the Rack	34

Chapter 3: Maintenance and Component Installation	36
3.1 Removing Power	38
Removing Power from a Node	38
Removing Power from the System	38
3.2 Accessing the System	39
Removing the Chassis Cover	39
3.3 Static-Sensitive Devices	40
Precautions	40
3.4 Processor and Heatsink Installation	41
Dual Socket BR (LGA-7529) Processors	42
Processor Top View	42
Overview of the Processor Carrier	42
Overview of the Processor Socket	45
Overview of the Processor Heatsink Module	45
Installing the Processor	47
Assembling the Processor Heatsink Module	50
3.5 Memory Support and Installation	52
General Guidelines for Optimizing Memory Performance	52
Memory Support	52
The Intel® Xeon® 6900 series processors with P-cores	53
DIMM Installation	54
DIMM Removal	57
3.6 Motherboard Battery Removal and Installation	58
Battery Removal	58
Proper Battery Disposal	58
Battery Installation	58
3.7 Storage Drives	59
Removing a Drive Carrier from the Chassis	60
Installing a Drive into a Drive Carrier	61
Hot-Swap for NVMe Drives	61
Ejecting a Drive	61
Replacing a Drive	62
3.8 System Cooling	63
Fans	63

Changing a System Fan	63
Air Shrouds	65
Installing an Air Shroud	65
3.9 GPU and PCIe Cards	66
Installing Expansion Cards	67
3.10 Power Supply	68
Replacing the Power Supply	68
Chapter 4: Motherboard Connections, Jumpers, and LEDs	70
4.1 Power Supply and Power Connections	72
Power Supply Connections	72
4.2 Headers and Connections	73
Power Supply and Power Connections	73
Power Supply Connections	73
Control Panel	73
Power Button	74
Reset Button	74
Power Fail LED	74
UID LED	75
Fail LED (Information LED for OH/FF/PF)	75
NIC1/NIC2 (LAN1/LAN2)	76
UID Switch/HDD LED	76
Power LED	76
NMI Button	77
Chassis Intrusion	77
External BMC I ² C Header	77
Fan Headers	78
Liquid Cooling Leakage Sensor Header	78
M.2 Slots	78
MCIO PCIe 5.0 x8 Connectors	79
NC-SI Connection	79
NVMe I ² C Header	79
NVMe I ² C Header	79
PDB CPLD Connector	79
TPM/Port 80 Header	80

VROC RAID Key Header	80
4.3 I/O Connection	82
Advanced I/O Module (AIOM) for I/O Support	82
4.4 Jumper Settings	83
CMOS Clear	83
4.5 LED Indicators	85
M.2 LEDs	85
BMC Heartbeat LED	85
Onboard Power LED	85
Unique Identifier LED (UID)	86
Chapter 5: Software	87
5.1 Microsoft Windows OS Installation	88
Installing the OS	88
5.2 Driver Installation	90
5.3 BMC	91
BMC ADMIN User Password	91
5.4 Logging into the BMC	92
Chapter 6: Optional Components	93
6.1 TPM Security Module	94
6.2 HBA Card	95
6.3 RAID Cards	96
6.4 Cable Management Arm	97
Installing the Cable Management Arm	98
Removing the Cable Management Arm	99
6.5 Intel Virtual RAID on CPU (VROC)	100
Requirements and Restrictions	100
Additional Information	100
Hardware Key	101
Configuring Intel VMD	101
Configuring VMD Manually	102
Creating NVMe RAID Configurations	105
Status Indications	107
Hot-Swap Drives	107
Hot-Unplug	107

Hot-Plug	108
Related Information Links	108
Chapter 7: Troubleshooting and Support	109
7.1 Online Resources	110
Website	110
Direct Links for the SYS-422GA-NRT System	110
Direct Links for General Support and Information	110
7.2 Baseboard Management Controller (BMC)	111
7.3 Troubleshooting Procedures	112
Before Power On	112
No Power	112
No Video	112
System Boot Failure	112
Memory Errors	113
Losing the System's Setup Configuration	113
If the System Becomes Unstable	113
7.4 CMOS Clear	115
7.5 Motherboard Battery	116
7.6 Where to Get Replacement Components	117
7.7 Technical Support Procedures	118
Returning Merchandise for Service	118
7.8 Feedback	120
Chapter 8: UEFI BIOS	121
8.1 Introduction	122
Updating BIOS	122
Starting the Setup Utility	122
8.2 Main Setup	124
8.3 Advanced Setup Configurations	126
Boot Feature Menu	126
CPU Configuration Menu	128
Advanced Power Management Configuration Menu	131
CPU P State Control Menu	132
Hardware PM State Control Menu	135
CPU C State Control Menu	135

Package C State Control Menu	136
CPU1 Core Disable Bitmap Menu	136
Chipset Configuration Menu	137
Uncore Configuration Menu	137
Memory Configuration Menu	139
Memory Topology Menu	139
Memory Map Menu	140
Memory RAS Configuration Menu	140
Security Configuration Menu	142
IIO Configuration Menu	147
CPU1 Configuration Menu	148
Intel VT for Directed I/O (VT-d) Menu	150
PCIe Leaky Bucket Configuration Menu	150
Super IO Configuration Menu	151
Serial Port 1 Configuration Menu	151
Serial Port 2 Configuration Menu	152
Serial Port Console Redirection Menu	152
Network Stack Configuration Menu	155
MAC:(MAC address)-IPv4 Network Configuration Menu	156
MAC:(MAC address)-IPv6 Network Configuration Menu	157
PCIe/PCI/PnP Configuration Menu	158
ACPI Settings Menu	160
Trusted Computing Menu	161
Supermicro KMS Server Configuration Menu	163
Super-Guardians Configuration Menu	165
HTTP Boot Configuration Menu	167
Intel(R) Ethernet Controller Menu	168
TLS Authenticate Configuration Menu	169
Driver Health Menu	170
8.4 Event Logs	171
8.5 BMC	173
System Event Log Menu	173
BMC Network Configuration Menu	174
8.6 Security	177

Supermicro Security Erase Configuration Menu	178
HDD Security Configuration Menu	179
Secure Boot Menu	180
TCG Storage Security Configuration Menu	183
8.7 Boot	184
8.8 Save & Exit	186
Appendix A: BIOS Codes	188
BIOS Error POST (Beep) Codes	188
Additional BIOS POST Codes	188
Appendix B: Standardized Warning Statements for AC Systems	189
Standard Warning Definition	189
Electrical Warning Definition	191
Installation Instructions	193
Circuit Breaker	194
Power Disconnection Warning	195
Equipment Installation	197
Rack Stability Hazard	199
Rack-Mounted Equipment Warning	201
Restricted Access Location	202
Battery Handling	204
Redundant Power Supplies	206
Backplane Voltage	207
Comply with Local and National Electrical Codes	209
Fan Warning	210
Connection to Earth	212
Power Cable and AC Adapter	213
Product Disposal	216
Appendix C: System Specifications	218
Appendix D: General Data Center Environmental Specifications	221

Contacting Supermicro

Headquarters

Address: Super Micro Computer, Inc.
980 Rock Ave.
San Jose, CA 95131 U.S.A.

Tel: +1 (408) 503-8000

Fax: +1 (408) 503-8008

Email: Marketing@supermicro.com (General Information)
Sales-USA@supermicro.com (Sales Inquiries)
[Government Sales-USA@supermicro.com](mailto:Government_Sales-USA@supermicro.com) (Gov. Sales Inquiries)
Support@supermicro.com (Technical Support)
RMA@Supermicro.com (RMA Support)
Webmaster@supermicro.com (Webmaster)

Website: <https://www.supermicro.com>

Europe

Address: Super Micro Computer B.V.
Het Sterrenbeeld 28, 5215 ML
's-Hertogenbosch, The Netherlands

Tel: +31 (0) 73-6400390

Fax: +31 (0) 73-6416525

Email: Sales_Europe@supermicro.com (Sales Inquiries)
Support_Europe@supermicro.com (Technical Support)
RMA_Europe@supermicro.com (RMA Support)

Website: <https://www.supermicro.nl>

Asia-Pacific

Address: Super Micro Computer, Inc.
3F, No. 150, Jian 1st Rd.
Zhonghe Dist., New Taipei City 235 Taiwan (R.O.C)

Tel: +886 (2) 8226-3990

Fax: +886 (2) 8226-3992

Email: Sales-Asia@supermicro.com.tw (Sales Inquiries)
Support@supermicro.com.tw (Technical Support)
RMA@supermicro.com.tw (RMA Support)

Website: <https://www.supermicro.com.tw>

Chapter 1:

Introduction

This chapter provides a brief outline of the functions and features of the SYS-422GA-NRT system. It is based on the MBD-X14DBG-AP motherboard and the CSE-418G3TS-R000NFP chassis.

1.1 Overview	14
1.2 System Features	15
Front View	15
Rear View	17
1.3 System Architecture	19
Main Components	19
Motherboard Block Diagram	20
1.4 Motherboard Quick Reference	21
Motherboard Overview	21
Quick Reference	22

1.1 Overview

This chapter provides a brief outline of the functions and features of the GPU SuperServer SYS-422GA-NRT. The following provides an overview of the system specifications and capabilities.

System Overview	
Motherboard	MBD-X14DBG-AP
Chassis	CSE-418G3TS-R000NFP
Processor	Dual Socket BR (LGA-7529) Intel® Xeon® 6900 series processors with P-cores, up to 128 cores/256 threads, up to 504 MB cache, up to 500 W TDP (air cooled).
Memory	24 DIMM slots per node, supporting up to 3 TB 8800 MT/s ECC DDR5 MRDIMM or up to 3 TB 6400 MT/s ECC DDR5 RDIMM (1DPC).
Drive Support	Internal Storage: Two M.2 NVMe slots (M-key) Drive Bay Options: Option A: Eight front hot-swappable E3.S 1T PCIe 5.0 x4 NVMe drive bays Option B: Eight front hot-swappable E3.L 1T PCIe 5.0 x4 NVMe drive bays Option C: Eight front hot-swappable 2.5" PCIe 5.0 x4 NVMe drive bays
Expansion Slots	PCIe Configuration by default: 13 PCIe 5.0 x16 FHFL slots M.2: Two M.2 PCIe 5.0 x4 NVMe slots (B+M-key)
I/O Ports	LAN: Two RJ45 10 GbE LAN ports (Intel® X710-AT2) and one dedicated RJ45 IPMI port USB: Two USB 3.0 Type-A ports (Rear) Video: One VGA port TPM: One TPM header
System Cooling	Fans: Ten 8-cm heavy-duty fans with optimal fan speed control Air Shroud: One primary, up to five optional (depending on add-on cards)
Power	Four 3200 W Redundant (3 + 1) Titanium Level (96%) power supplies Input: 1400 W: 100–127 VAC / 50-60 Hz / 16–15.4 A 3200 W: 219.1–240 VAC / 50-60 Hz / 16–14.8 A
Form Factor	17.2" x 7" x 29" (437 x 178 x 737 mm) (W x H x D)

1.2 System Features

The following views of the system display the main features. Refer to the System Specifications appendix of this manual for additional specifications.

Front View

The following features are located on the front of the SYS-422GA-NRT server.

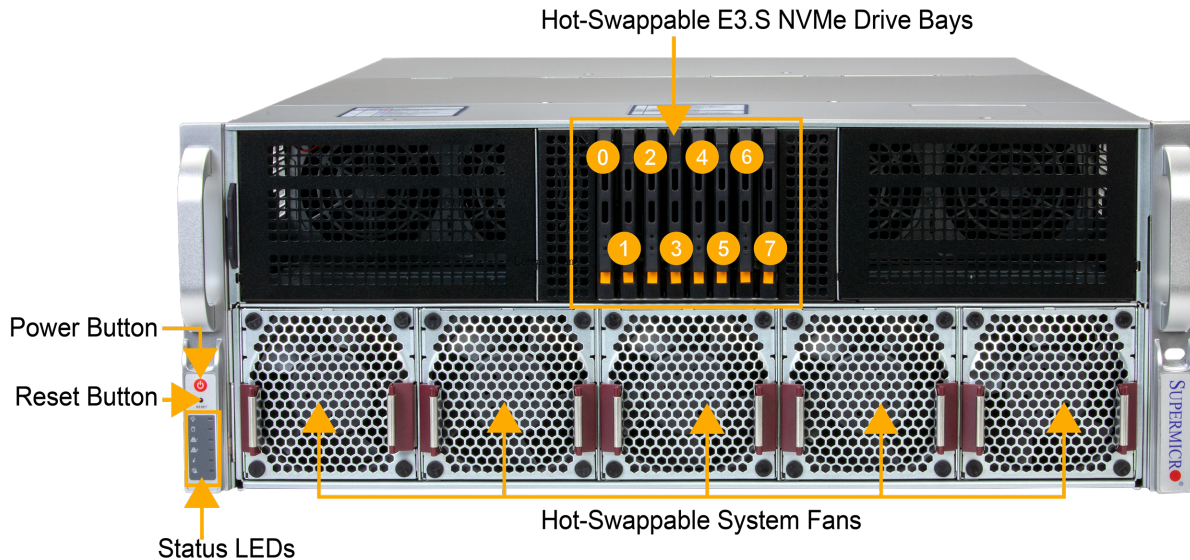

Figure 1-1. SYS-422GA-NRT Front View

System Features: Front	
Feature	Description
NVMe Drive Bays	Eight hot-swappable E3.S NVMe drive bays
Power Button	Applies or removes primary power from the power supply to the server, but maintains standby power.
Reset Button	The reset button is used to reset the system.
Status LEDs	LED indicators for system status
System Fans	Five hot-swappable system fans (front; additional fans located in the middle)

Control Panel

The following switches and LEDs are located on the SYS-422GA-NRT server control panel.

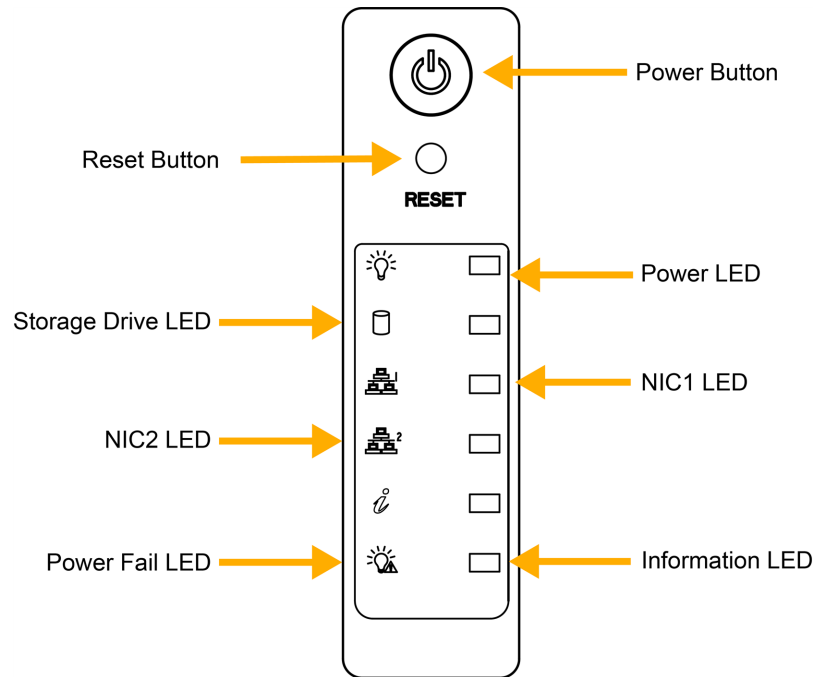

Figure 1-2. SYS-422GA-NRT Control Panel

Control Panel Features	
Feature	Description
Power Button	Applies or removes primary power from the power supply to the server but maintains standby power.
Reset Button	Resets the system.
Power LED	Indicates power is being supplied to the system power supply units. This LED is illuminated when the system is operating normally.
Storage Drive LED	Indicates activity on the storage drives when flashing.
NIC1 LED	Indicates network activity on LAN1 when flashing.
NIC2 LED	Indicates network activity on LAN2 when flashing.
Information LED	Alerts operator to several states, as noted in the table below.
Power Fail LED	Indicates a power supply module has failed.

Information LED	
Color, Status	Description
Red, solid	An overheat condition has occurred.

Information LED	
Color, Status	Description
Red, blinking at 1 Hz	Fan failure; check for an inoperative fan.
Red, blinking at 0.25 Hz	Power failure; check for an inoperative power supply.
Red, solid with Power LED blinking green	Fault detected.
Blue and red, blinking at 10 Hz	Recovery mode.
Blue, solid	UID has been activated locally to locate the server in a rack environment.
Blue, blinking at 1 Hz	UID has been activated via BMC to locate the server in a rack environment.
Blue, blinking at 2 Hz	BMC is resetting.
Blue, blinking at 4 Hz	BMC is setting factory defaults.
Blue, blinking at 10 Hz with Power LED blinking green	BMC/BIOS firmware is updating.

Rear View

The following features are located on the front of the SYS-422GA-NRT server.

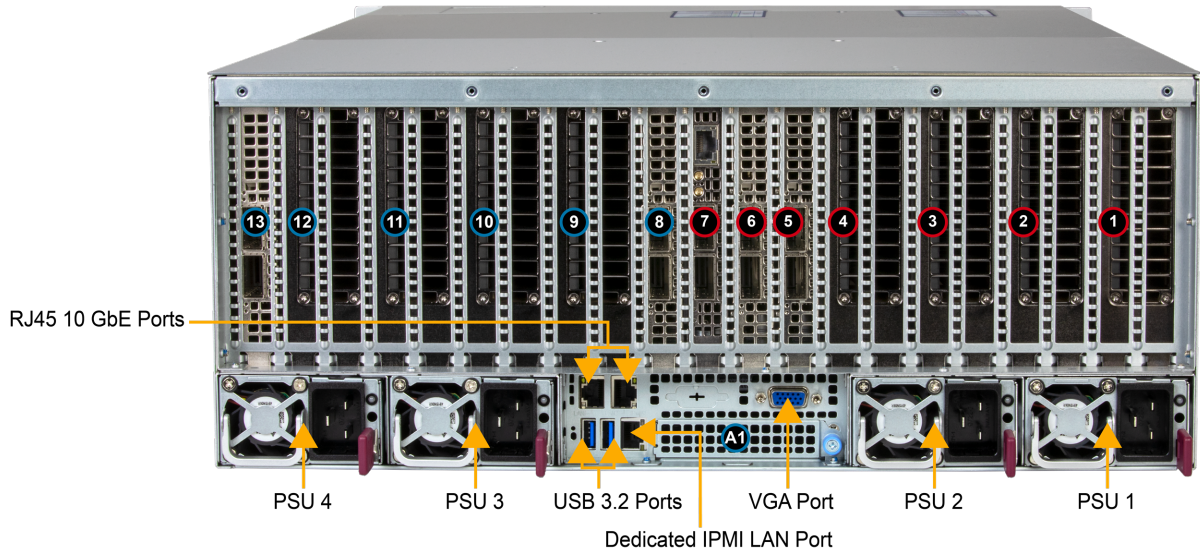

Figure 1-3. SYS-422GA-NRT Rear View

System Features: Rear	
Feature	Description
PCIe Slots	13 PCIe 5.0 x16 FHFL slots
Power Supplies	Four hot-swappable redundant power supply modules

System Features: Rear	
Feature	Description
USB 3.2 Ports	Two USB 3.2 ports
RJ45 10 GbE Ports	Two RJ45 10 GbE Ports
VGA Port	One VGA interface for video
Dedicated IPMI LAN Port	One dedicated IPMI LAN port

Expansion Slot Locations (All PCIe 5.0)		
Item	Description	Controlled by
1	x16 slot	CPU1 (via PLX)
2	x16 slot	CPU1 (via PLX)
3	x16 slot	CPU1 (via PLX)
4	x16 slot	CPU1 (via PLX)
5	x16 slot	CPU1 (via PLX)
6	x16 slot	CPU1 (via PLX)
7	x16 slot	CPU1 (direct)
8	x16 slot	CPU2 (via PLX)
9	x16 slot	CPU2 (via PLX)
10	x16 slot	CPU2 (via PLX)
11	x16 slot	CPU2 (via PLX)
12	x16 slot	CPU2 (via PLX)
13	x16 slot	CPU2 (via PLX)
A1	x16 slot	CPU2 (OCP 3.0)

Power Supply Indicators		
Power Supply Condition	Green LED	Amber LED
No AC power to power supply	Off	Off
Power supply critical events causing a shutdown/failure/OCP/OVP/Fan Fail/OTP/UVP	Off	On
Power supply warning events where the power supply continues to operate; high temperature; over voltage; under voltage, etc.	Off	1 Hz Blinking
AC present only 12 VSB ON (PS OFF)	1 Hz Blinking	Off
Output ON and OK	On	Off
AC cord unplugged and in redundant mode	Off	On

1.3 System Architecture

This section covers the locations of the system's main components and provides a motherboard block diagram.

Main Components



Figure 1-4. SYS-422GA-NRT Main Component Locations

System Features: Top	
Feature	Description
M.2 NVMe Slots	Two M.2 NVMe slots
DIMM Slots	24 DDR5 DIMM slots
Processors	Dual Intel® Xeon® 6900 Series Processors

System Features: Top

System Fans

Five hot-swappable system fans

Motherboard Block Diagram

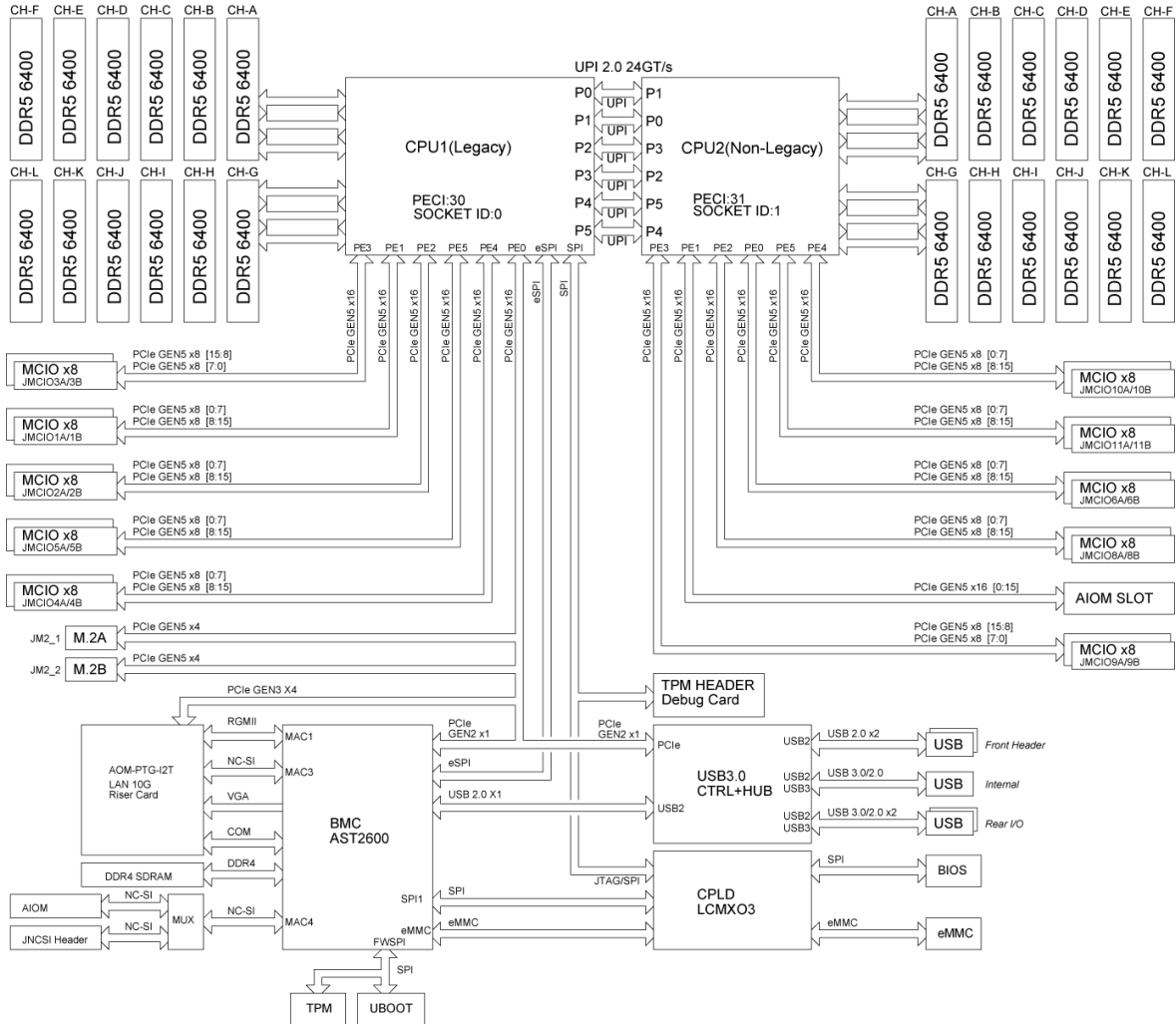

Figure 1-5. MBD-X14DBG-AP Block Diagram

Note: This is a general block diagram and may not exactly represent the features on your motherboard. For the actual specifications of your motherboard, see "[Motherboard Quick Reference](#)" on the next page.

1.4 Motherboard Quick Reference

For details on the MBD-X14DBG-AP motherboard layout and other quick reference information, refer to the content below.

Motherboard Overview

This chapter provides detailed information on the components installed on the SYS-422GA-NRT server as well as the features supported by the GPU SuperServer.

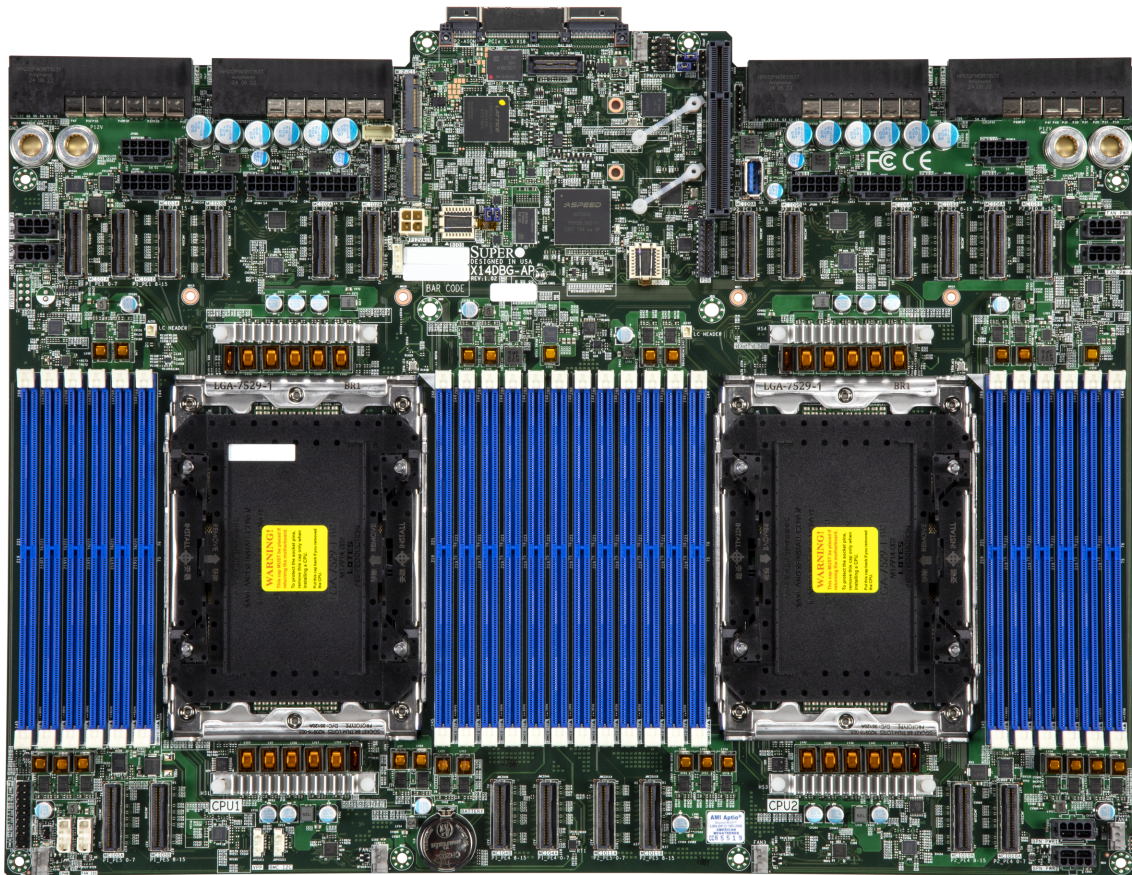

Figure 1-6. MBD-X14DBG-AP Motherboard Image

LED	Description	Status
LED1, LED2	M.2 Activity LED	Blinking Green: M.2 Devices Working Normally
LEDBMC	BMC Heartbeat LED	Blinking Green: BMC Normal (Active), Solid Green: (During BMC Reset or during a Cold Reboot)
LEDPWR	Power LED	LED On: Onboard Power On
UID_LED	Unit Identifier (UID) LED	Solid Blue: Unit Identification LED

Connector	Description
Battery (BT1)	Onboard Battery
FAN1–FAN4	4-pin Fan Headers
FANSTBY	System Fan to run during S5
JAIOM1	Supermicro Advanced Input/Output Module (AIOM) PCIe 5.0 x16 Connector for I/O support
JBPNI2C1	I ² C connector for NVMe backplane
JF1	Front Panel Header
JIPMB1	IPMB Header
JIPMB2	Fan Board PMBUS Header
JL1	Chassis Intrusion Header
JLCS1, JLCS2	Liquid Leakage Detection Sensor Headers
JM2_1, JM2_2	M.2 Connectors (M-key)
JMCIO1A, 1B, 2A, 2B, 3A, 3B, 4A, 4B, 5A, 5B, 6A, 6B, 8A, 8B, 9A, 9B, 10A, 10B, 11A, 11B	MCIO Connectors for Processor PCIe Connections
JNCSI1	Network Controller Sideband Interface Header
JNCSI2_BF	Network Controller Sideband Interface Header for Bluefield-3
JNVI2C1	VPP Header for NVMe Devices
JPDB1	Connection for communication to PDB CPLD
JPGW1–10	CEM5 GPU Power Connector
JPW1–4	Power Supply Unit Connectors

Connector	Description
JPWR1-4	Fan Connectors
JPWR5-6	Backplane Power Connectors
JPWR_STBY	12 V AUX Power Connector
JRK1	Intel VROC RAID Key Header
JSLOT1	AOM-PTG-I2T I/O Riser Card Connection
JTPM1	Trusted Platform Module/Port 80 Connector
PWR1-4	Power Bus Bar for AOM-PCIE5-418P and PDB
USB2 (3.0) (J25)	USB Header with support for USB 3.0 Port

Note: For detailed instructions on how to configure VROC RAID settings, refer to the VROC RAID Configuration User's Guide posted on the web page under the following link: <https://www.supermicro.com/support/manuals>.

Chapter 2:

Server Installation

This chapter provides advice and instructions for mounting your server in a server rack. If your server is not already fully integrated with processors, system memory, etc., refer to ["Maintenance and Component Installation" on page 36](#) for details on installing those specific components.

Important: Electrostatic Discharge (ESD) can damage electronic components. To prevent such damage to printed circuit boards (PCBs), it is important to use a grounded wrist strap, handle all PCBs by their edges, and keep PCBs in anti-static bags when not in use.

2.1 Unpacking the System	26
2.2 Preparing for Setup	27
Choosing a Setup Location	27
Rack Precautions	27
System Precautions	27
Rack Mounting Considerations	28
2.3 Installing the Rails	30
Identifying the Rails	30
Installing the Inner Rails onto the Chassis	31
Installing the Outer Rails onto the Rack	31
2.4 Installing the Chassis into the Rack	33
Removing the Chassis from the Rack	34

2.1 Unpacking the System

Inspect the box the SYS-422GA-NRT server was shipped in and note if it was damaged in any way. If any equipment appears damaged, file a damage claim with the carrier who delivered it.

Decide on a suitable location for the rack unit that will hold the server. It should be situated in a clean, dust-free area that is well ventilated. Avoid areas where heat, electrical noise and electromagnetic fields are generated. It will also require a grounded AC power outlet nearby. Be sure to read the precautions and considerations noted in ["Standardized Warning Statements for AC Systems"](#) on page 189.

2.2 Preparing for Setup

The box in which the SYS-422GA-NRT server was shipped should include the rackmount hardware needed to install it into the rack. Read this section in its entirety before you begin the installation.

Choosing a Setup Location

- The server should be situated in a clean, dust-free area that is well ventilated. Avoid areas where heat, electrical noise and electromagnetic fields are generated.
- Leave enough clearance in front of the rack so that you can open the front door completely (~25 inches) and approximately 30 inches of clearance in the back of the rack to allow sufficient space for airflow and access when servicing.
- This product should be installed only in a Restricted Access Location (dedicated equipment rooms, service closets, etc.).
- This product is not suitable for use with visual display workplace devices according to §2 of the German Ordinance for Work with Visual Display Units.

Rack Precautions

- Ensure that the leveling jacks on the bottom of the rack are extended to the floor so that the full weight of the rack rests on them.
- In single rack installations, stabilizers should be attached to the rack. In multiple rack installations, the racks should be coupled together.
- Always make sure the rack is stable before extending a server or other component from the rack.
- You should extend only one server or component at a time. Extending two or more simultaneously may cause the rack to become unstable.

System Precautions

- Review the electrical and general safety precautions in "[Standardized Warning Statements for AC Systems](#)" on page 189.
- Determine the placement of each component in the rack before you install the rails.
- Install the heaviest server components at the bottom of the rack first and then work your way up.

- Use a regulating uninterruptible power supply (UPS) to protect the server from power surges and voltage spikes and to keep your system operating in case of a power failure.
- Allow any drives and power supply modules to cool before touching them.
- When not servicing, always keep the front door of the rack and all covers/panels on the servers closed to maintain proper cooling.

Rack Mounting Considerations



Warning! Stability hazard. The rack may tip over causing serious personal injury. Before extending the rack to the installation position, read the installation instructions. Do not put any load on the slide-rail mounted equipment in the installation position. Do not leave the slide-rail mounted equipment in the installation position.



Avertissement!

Danger d'instabilité. Le rack peut basculer et provoquer des blessures corporelles graves.

Avant d'étendre le rack en position d'installation, lire les instructions d'installation. Ne pas charger l'équipement monté sur rail de glissière en position d'installation. Ne pas laisser l'équipement monté sur rail de glissière en position d'installation.

Important: To prevent bodily injury when mounting or servicing this unit in a rack, you must take special precautions to ensure that the system remains stable. The following guidelines are provided to ensure your safety:

- If this unit is the only unit in the rack, it should be mounted at the bottom of the rack.
- When mounting this unit in a partially filled rack, load the rack from the bottom to the top, placing the heaviest component at the bottom of the rack.
- If the rack is provided with stabilizing devices, install the stabilizers before mounting or servicing the unit in the rack.
- Slide rail mounted equipment is not to be used as a shelf or a workspace.
- Do not pick up the server with the front handles. They are designed to pull the system from a rack only.

Ambient Operating Temperature

If installed in a closed or multi-unit rack assembly, the ambient operating temperature of the rack environment may be greater than the room's ambient temperature. Therefore, consideration should be given to installing the equipment in an environment compatible with the manufacturer's maximum rated ambient temperature (TMRA).

Airflow

Equipment should be mounted into a rack so that the amount of airflow required for safe operation is not compromised.

Mechanical Loading

Equipment should be mounted into a rack so that a hazardous condition does not arise due to uneven mechanical loading.

Circuit Overloading

Consideration should be given to the connection of the equipment to the power supply circuitry and the effect that any possible overloading of circuits might have on overcurrent protection and power supply wiring. Appropriate consideration of equipment nameplate ratings should be used when addressing this concern.

Reliable Ground

A reliable ground must be maintained at all times. To ensure this, the rack itself should be grounded. Particular attention should be given to power supply connections other than the direct connections to the branch circuit (i.e. the use of power strips, etc.).

2.3 Installing the Rails

This section provides information on installing the CSE-418G3TS-R000NFP chassis into a rack unit with the rails provided. There are a variety of rack units on the market, which may mean that the assembly procedure will differ slightly from the instructions provided. You should also refer to the installation instructions that came with the rack unit you are using.

Note: This rail will fit a rack between 26.5" and 36.4" deep.

Identifying the Rails

The CSE-418G3TS-R000NFP chassis package includes two rail assemblies. Each assembly consists of three sections: an inner rail that secures directly to the chassis, an outer rail that secures to the rack, and a middle rail which extends from the outer rail. These assemblies are specifically designed for the left and right side of the chassis and labeled.

Note: Both front chassis rails and the rack rails have a locking tab, which serves two functions. First, it locks the chassis into place when installed and pushed fully into the rack (its normal operating position). In addition, these tabs lock the chassis in place when fully extended from the rack. This prevents the chassis from coming completely out of the rack when pulled out for servicing.

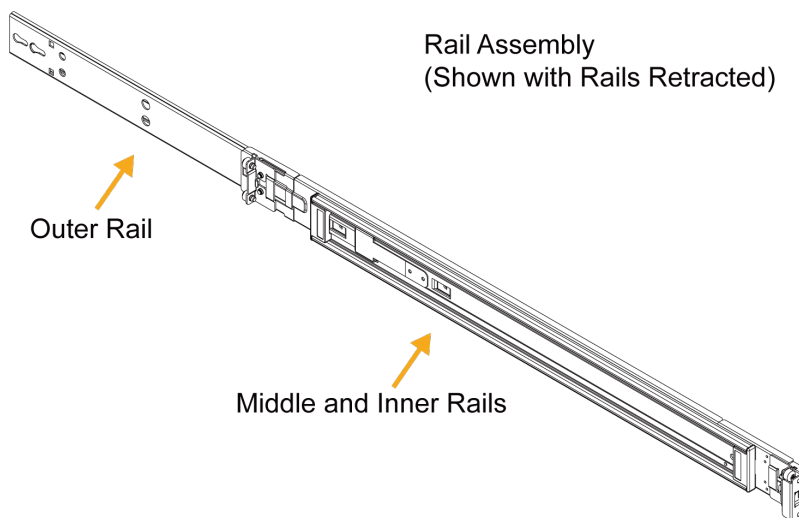

**Figure 2-1. Identifying the Outer, Middle, and Inner Rails
(Left Rail Assembly Shown)**

Installing the Inner Rails onto the Chassis

Important: Do not pick up the server with the front handles. They are designed to pull the system from a rack only.

Begin the rack mounting procedure by installing the inner rails to the CSE-418G3TS-R000NFP chassis.

1. Confirm that the left and right inner rails have been correctly identified.
2. Place the inner rail firmly against the side of the chassis, aligning the hooks on the side of the chassis with the holes in the inner rail.
3. Slide the inner rail forward toward the front of the chassis and under the hooks until the quick release bracket snaps into place, securing the rail to the chassis.
4. Optionally, you can further secure the inner rail to the chassis with a screw.
5. Repeat for the other inner rail.

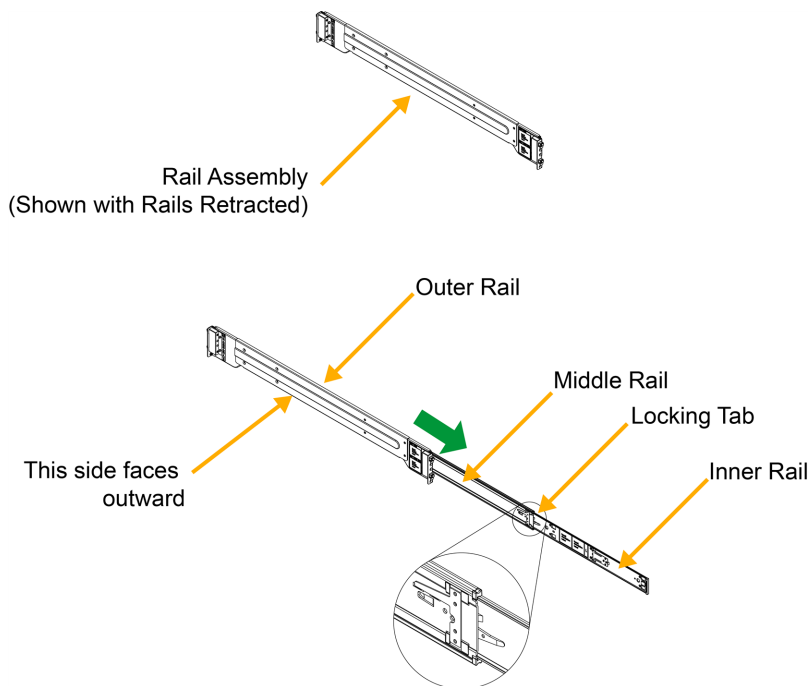

Figure 2-2. Installing the Inner Rails

Installing the Outer Rails onto the Rack

Each end of the assembled outer rail includes a bracket with hooks and square, spring-loaded pegs to fit into the square holes in your rack.

Important: Stability hazard. The rack stabilizing mechanism must be in place, or the rack must be bolted to the floor before you slide the unit out for servicing. Failure to stabilize the rack can cause the rack to tip over.

Important: Do not pick up the server with the front handles. They are designed to pull the system from a rack only.

1. Confirm that the left and right outer rails have been correctly identified.
2. Press upward on the locking tab at the rear end of the middle rail.
3. Push the middle rail back into the outer rail.
4. Hang the hooks on the front of the outer rail onto the square holes on the front of the rack. If desired, use screws to secure the outer rails to the rack.
5. Pull out the rear of the outer rail, adjusting the length until it just fits within the posts of the rack.
6. Hang the hooks of the rear section of the outer rail onto the square holes on the rear of the rack. Take care that the proper holes are used so the rails are level. If desired, use screws to secure the rear of the outer rail to the rear of the rack.
7. Repeat for the other outer rail.

Important: This figure is for illustrative purposes only. Always install servers to the bottom of a rack first.

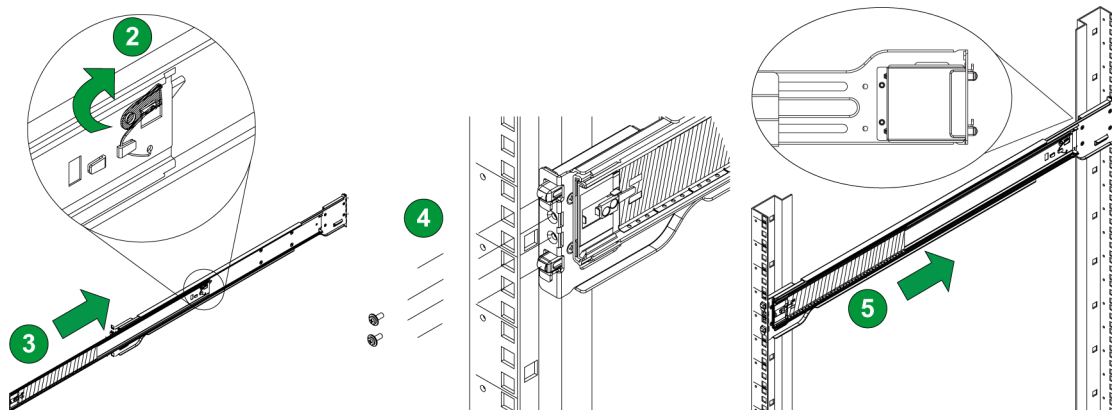

Figure 2-3. Extending and Mounting the Outer Rails

2.4 Installing the Chassis into the Rack

Important: Use caution when mounting or removing the system from the rack. For large systems, at least one other person must assist during installation or removal. Follow the safety recommendations printed on the rails. Depending on the size of the system, you might need to use a lift.

1. Confirm that the inner and outer rails are properly installed on the chassis.
2. Pull the middle rail out from the front of the outer rail. Make sure that the ball-bearing shuttle is at the front locking position of the middle rail.
3. Align the chassis inner rails with the front of the middle rails.
4. Slide the inner rails on the chassis into the middle rails, keeping the pressure even on both sides, until the locking tab of the inner rail clicks into the front of the middle rail, locking the chassis into the fully extended position.
5. Depress the locking tabs of both sides at the same time and push the chassis all the way into the rear of the rack.
6. If necessary, use screws to secure the chassis handles to the front of the rack.

Note: Keep the ball bearing shuttle locked at the front of the middle rail during installation.

Important: This figure is for illustrative purposes only. Always install servers to the bottom of a rack first.

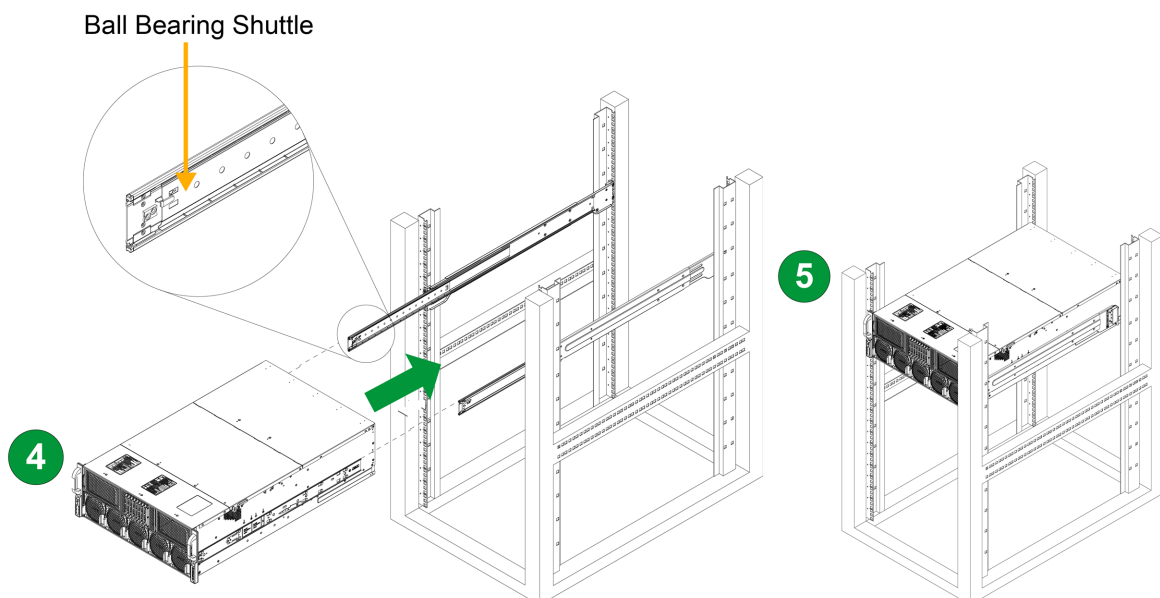

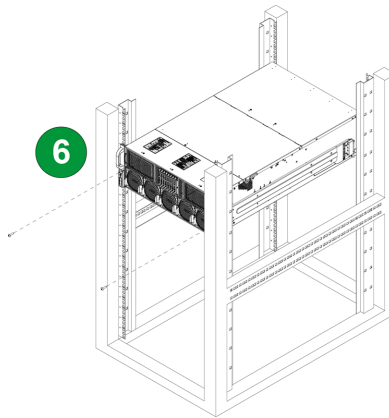

Figure 2-4. Sliding the SYS-422GA-NRT into the Rack

Removing the Chassis from the Rack

Important: Use caution when mounting or removing the system from the rack. For large systems, at least one other person must assist during installation or removal. Follow the safety recommendations printed on the rails. Depending on the size of the system, you might need to use a lift.

1. If necessary, loosen the thumbscrews on the front of the chassis that hold it in the rack.
2. Pull the chassis forward out the front of the rack until it stops.
3. Press the release latches on each of the inner rails downward simultaneously and continue to pull the chassis forward and out of the rack.

Important: This figure is for illustrative purposes only. Always install servers to the bottom of a rack first.

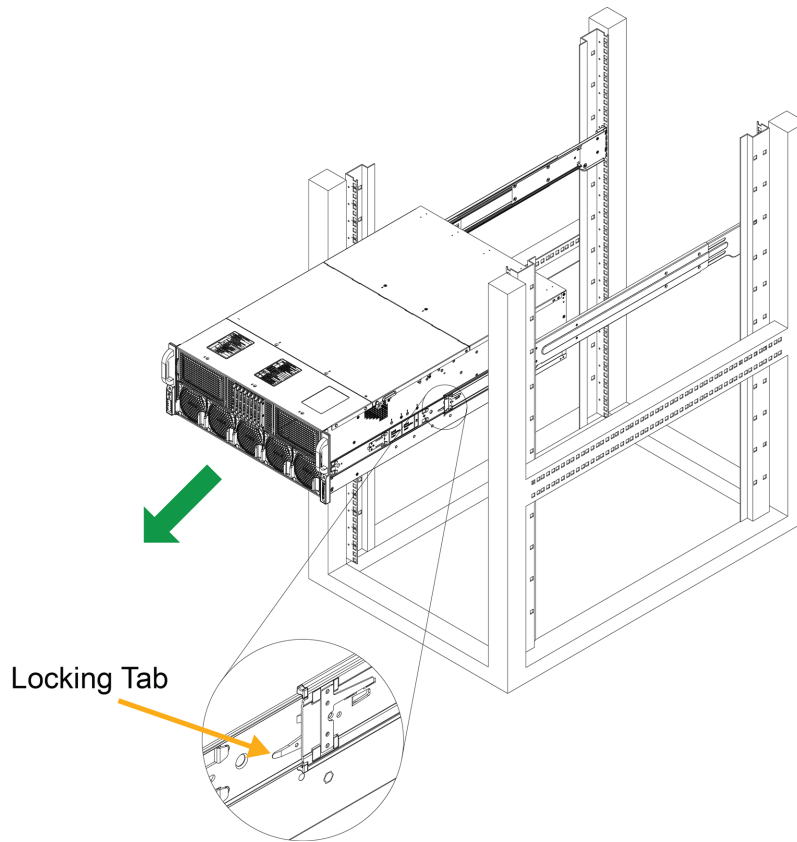

Figure 2-5. Removing the SYS-422GA-NRT from the Rack

Chapter 3:

Maintenance and Component Installation

This chapter provides instructions on installing and replacing main system components for the SYS-422GA-NRT server. To prevent compatibility issues, only use components that match the specifications and/or part numbers given.

Installation or replacement of most components require that power first be removed from the system. Follow the procedures given in each section.

3.1 Removing Power	38
Removing Power from a Node	38
Removing Power from the System	38
3.2 Accessing the System	39
Removing the Chassis Cover	39
3.3 Static-Sensitive Devices	40
Precautions	40
3.4 Processor and Heatsink Installation	41
Dual Socket BR (LGA-7529) Processors	42
Overview of the Processor Carrier	42
Overview of the Processor Socket	45
Overview of the Processor Heatsink Module	45
Installing the Processor	47
Assembling the Processor Heatsink Module	50
3.5 Memory Support and Installation	52
General Guidelines for Optimizing Memory Performance	52
Memory Support	52
DIMM Installation	54
DIMM Removal	57
3.6 Motherboard Battery Removal and Installation	58
Battery Removal	58
Proper Battery Disposal	58
Battery Installation	58
3.7 Storage Drives	59

Removing a Drive Carrier from the Chassis	60
Installing a Drive into a Drive Carrier	61
Hot-Swap for NVMe Drives	61
3.8 System Cooling	63
Fans	63
Air Shrouds	65
3.9 GPU and PCIe Cards	66
Installing Expansion Cards	67
3.10 Power Supply	68
Replacing the Power Supply	68

3.1 Removing Power

Before performing some setup or maintenance tasks, use the following procedure to ensure that power has been removed from one or more nodes of the SYS-422GA-NRT server.

Removing Power from a Node

Use the operating system to power down the node.

Removing Power from the System

1. Use the operating system to power down all nodes.
2. Grasp the head of each power cord and gently pull it out of the back of the power supply.
3. Disconnect the cords from the power strip or wall outlet.

3.2 Accessing the System

The SYS-422GA-NRT server features a removable top cover, which allows easy access to the inside of the server.

Removing the Chassis Cover

Important: Except for short periods of time, do not operate the server without the cover in place. The chassis cover must be in place to allow for proper airflow and to prevent overheating.

1. Remove power from the system as described in ["Removing Power"](#) on page 1.
2. Remove the two screws on each side of the cover, which secure the cover to the chassis. These two screws are optional and will not impact functionality if they are not installed.
3. Slide the cover toward the rear.
4. Lift the top cover up.
5. Check that all ventilation openings on the top cover and the top of the chassis are clear and unobstructed.

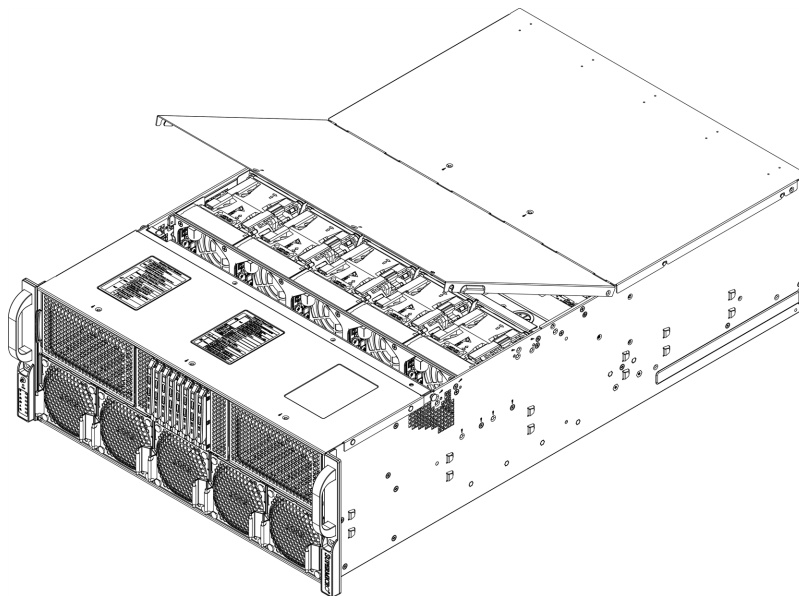

Figure 3-1. Removing the Chassis Cover

3.3 Static-Sensitive Devices

Electrostatic Discharge (ESD) can damage electronic components. To avoid damaging your motherboard, it is important to handle it very carefully. The following measures are generally sufficient to protect your equipment from ESD.

Precautions

- Use a grounded wrist strap designed to prevent static discharge.
- Touch a grounded metal object before removing the board from the antistatic bag.
- Handle the motherboard only by its edges. Do not touch its components, peripheral chips, memory modules, or gold contacts.
- When handling chips or modules, avoid touching their pins.
- Put the motherboard and peripherals back into their antistatic bags when not in use.
- For grounding purposes, make sure that your computer chassis provides excellent conductivity between the power supply, the case, the mounting fasteners, and the motherboard.
- Use only the correct type of onboard CMOS battery. To avoid possible explosion, do not install the onboard battery upside down.

3.4 Processor and Heatsink Installation

This section provides procedures to install the processor(s) and heatsink(s).

Notes:

- Take industry standard precautions to avoid ESD damage. For details, see "[Static-Sensitive Devices](#)" on the previous page.
- Before starting, make sure that the plastic socket cap is in place and none of the socket pins are bent. If any damage is noted, contact your retailer.
- Do not connect the system power cord before the processor and heatsink installation is complete.
- When handling the processor, avoid touching or placing direct pressure on the LGA lands (gold contacts). Improper installation or socket misalignment can cause serious damage to the processor or processor socket.
- When buying a processor separately, use only a Supermicro certified heatsink.
- Refer to the Supermicro website for the most recent processor support.
- When installing the heatsink, ensure a torque driver set to the correct force is used for each screw.
- Thermal grease is pre-applied on a new heatsink. No additional thermal grease is needed.

Dual Socket BR (LGA-7529) Processors

Processor Top View



Figure 3-2. Processor

Overview of the Processor Carrier

This section displays the MBD-X14DBG-AP motherboard processor carrier.

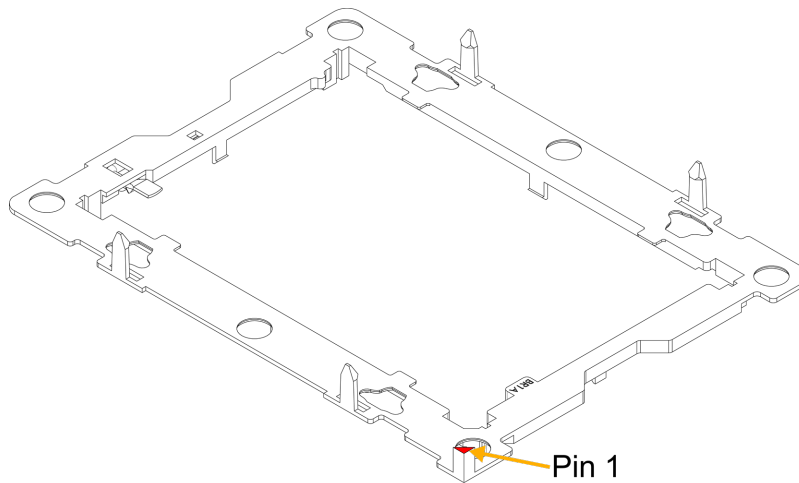

Figure 3-3. Carrier BR1A

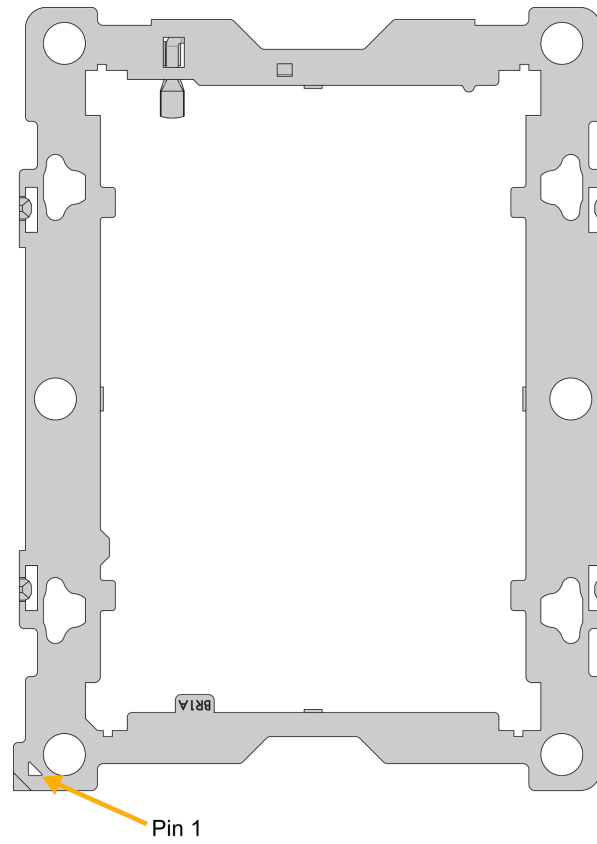

Figure 3-4. Carrier Top View

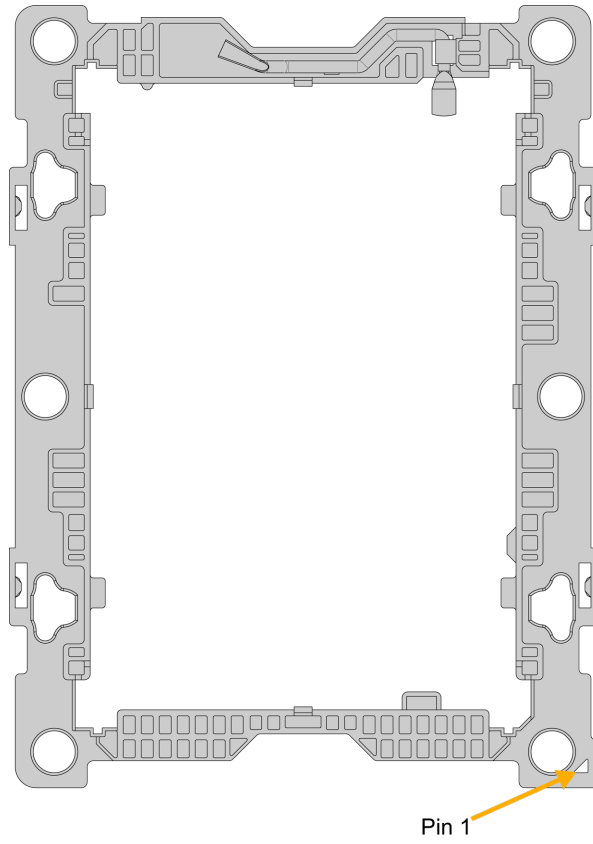

Figure 3-5. Carrier Bottom View

Overview of the Processor Socket

The processor socket is protected by a plastic protective cover.

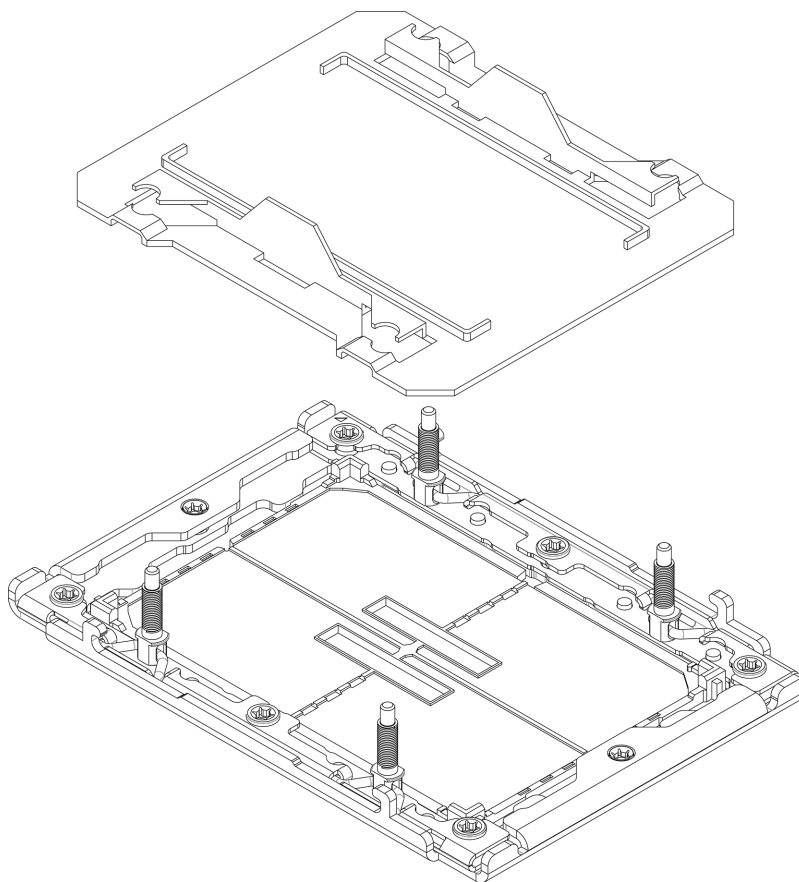

Figure 3-6. Plastic Protective Cover and Processor Socket

Overview of the Processor Heatsink Module

The Processor Heatsink Module (PHM) contains a heatsink, a processor carrier, and the processor.

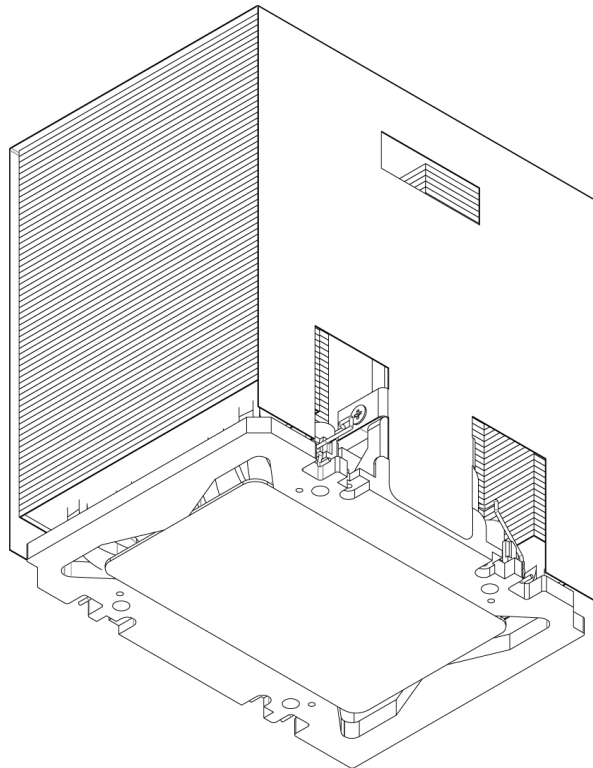

Figure 3-7. 4U Heatsink

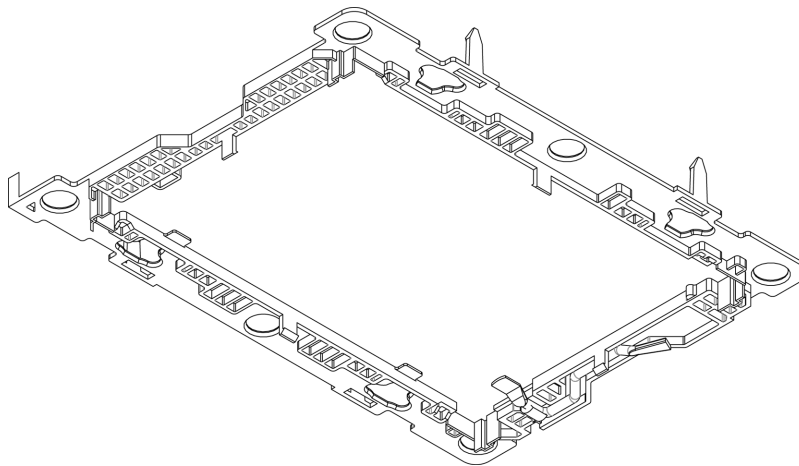

Figure 3-8. Carrier

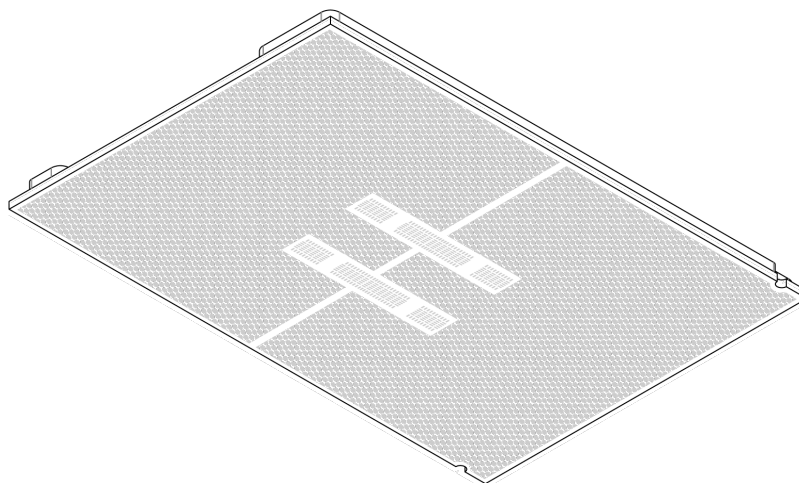

Figure 3-9. Processor

Installing the Processor

To install a processor into the processor carrier, follow the steps below:

1. Ensure the lever on the processor carrier is pressed down and held by a latch on the processor carrier as shown below.

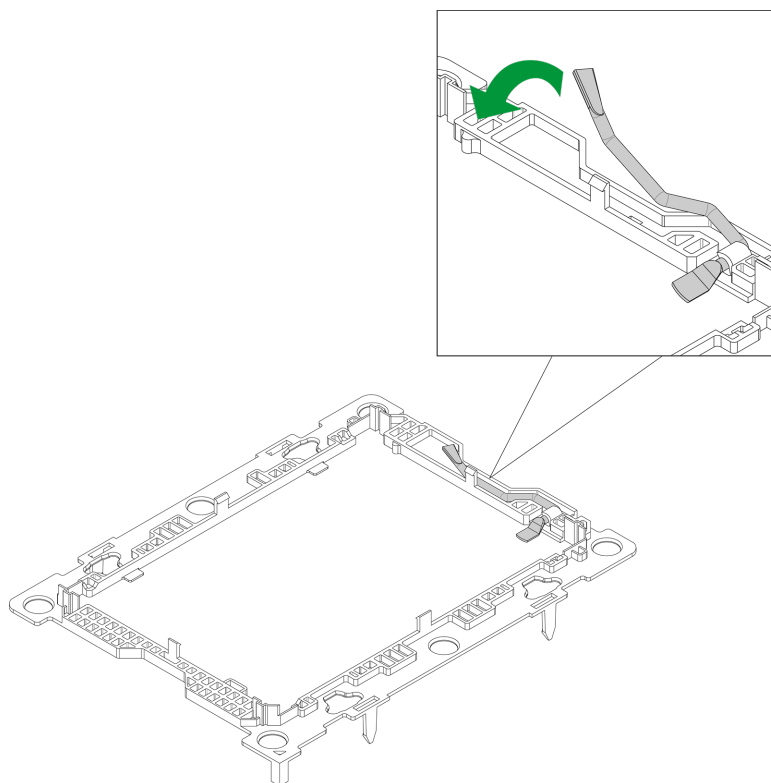

Figure 3-10. Carrier Lever

2. Hold the processor with the LGA lands (gold contacts) facing down. Locate the small, gold triangle in the corner of the processor and the corresponding hollowed triangle on the processor carrier. These triangles indicate pin 1.

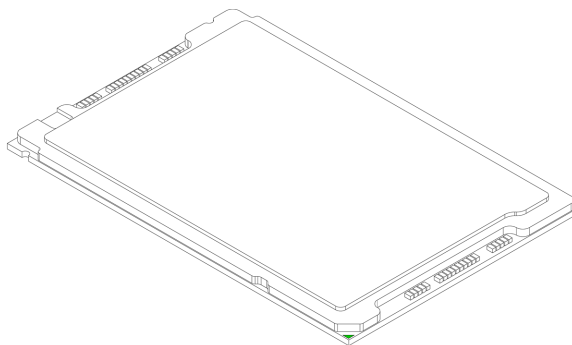

Figure 3-11. Processor

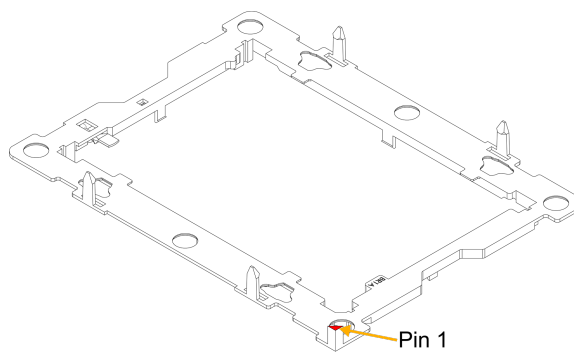

Figure 3-12. Carrier

3. While ensuring that the pin 1 triangles point towards the same direction, flip over the processor and processor carrier. Use the latches on the processor carrier to secure the processor onto the processor carrier. Processor keys on the processor and processor carrier will prevent securing the processor in an incorrect orientation.

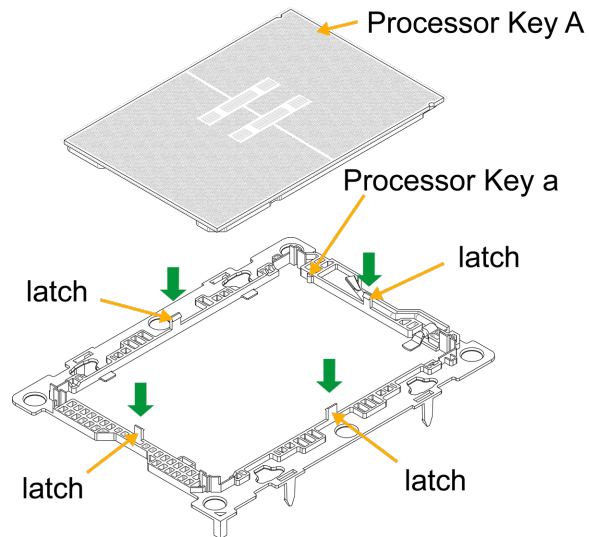

Figure 3-13. Key and Latch Locations

4. Examine all corners to verify that the processor is secured to the carrier. Two triangles indicating pin 1 on the processor and processor carrier should point towards the same direction.

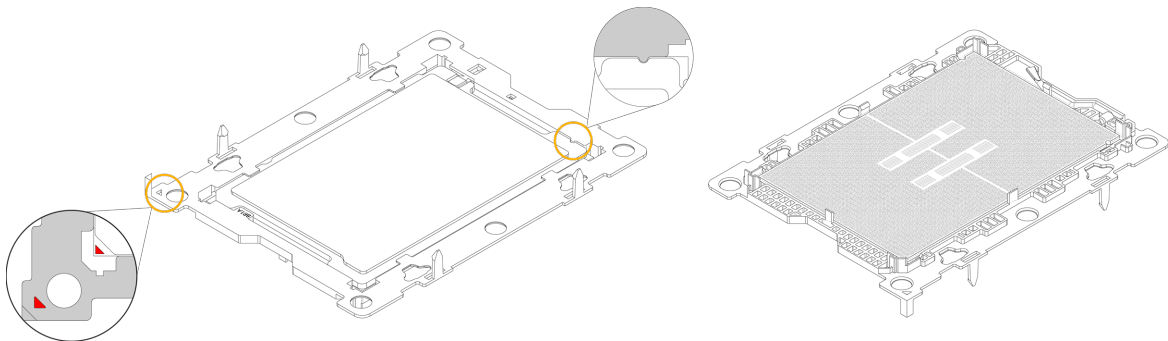

Figure 3-14. Processor and BR1A Keys and Latches

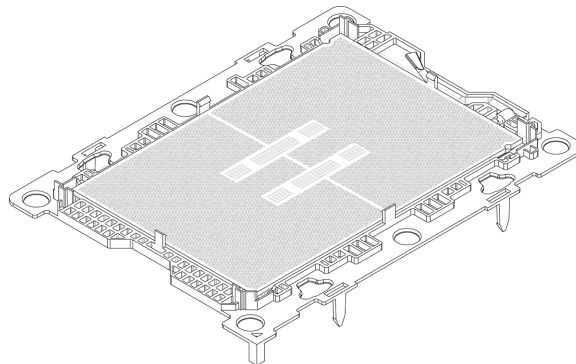

Figure 3-15. Completed Processor Carrier Installation

Assembling the Processor Heatsink Module

After installing the processor into the carrier, mount it onto the heatsink to create the processor heatsink module (PHM):

1. Note the label on top of the heatsink, which marks the airflow direction. Turn the heatsink over and orient the heatsink so the airflow arrow is pointing towards the triangle on the processor.
2. If this is a new heatsink, the thermal grease has been pre-applied. Otherwise, apply the proper amount of thermal grease.
3. Hold the processor carrier so the processor's gold contacts are facing up, then align the holes of the processor carrier with the holes on the heatsink. Press the processor carrier down until it snaps into place. The plastic clips of the processor carrier will lock at the four corners.

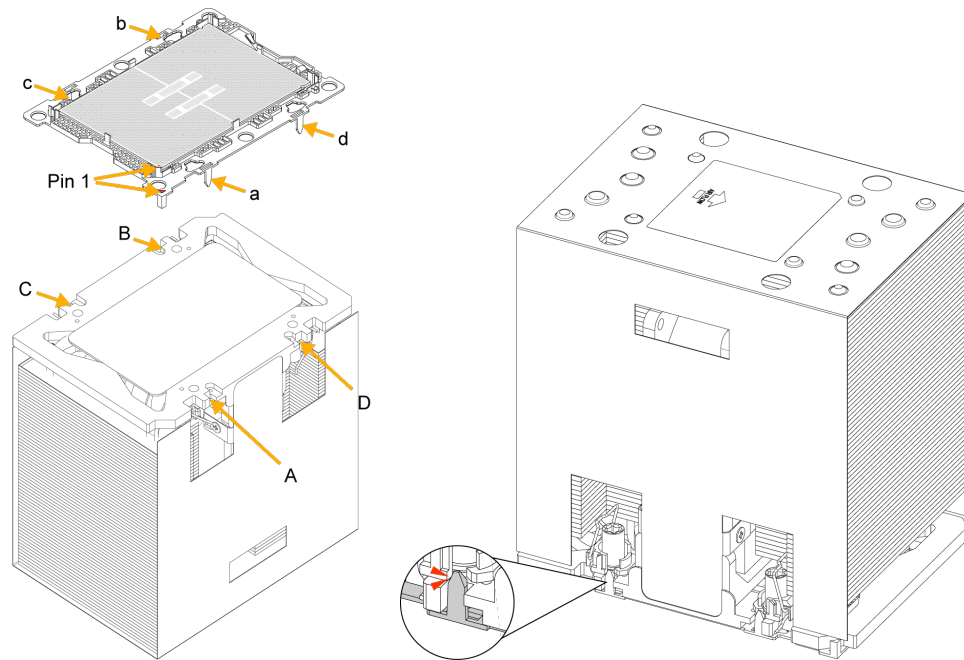

Figure 3-16. Carrier with 4U Heatsink (Left), PHM Plastic Clips Locked (Right)

4. Examine all corners to ensure that the plastic clips on the processor carrier are firmly attached to the heatsink.

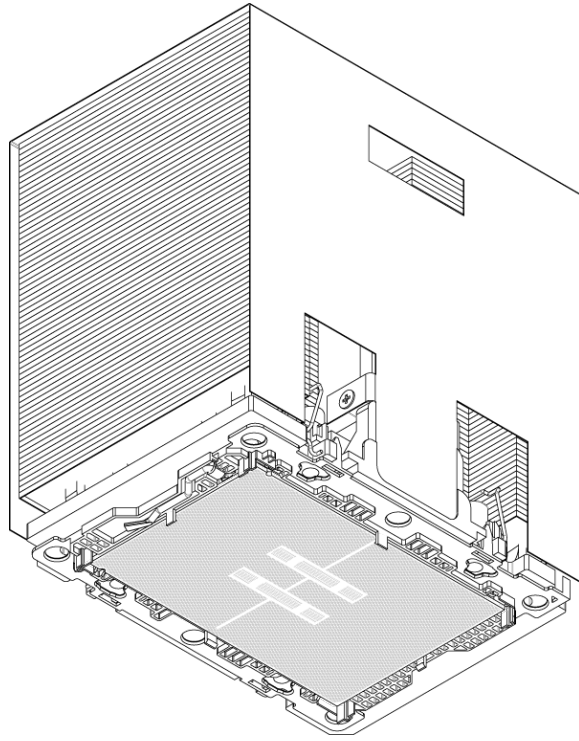

Figure 3-17. PHM Completed

3.5 Memory Support and Installation

Important: To prevent any damage, exercise extreme care when installing or removing memory modules.

Note: Check the Supermicro website for recommended memory modules.

General Guidelines for Optimizing Memory Performance

- It is recommended to use DDR5 memory of the same type, size, and speed.
- Mixed DIMM speeds can be installed. However, all DIMMs will run at the speed of the slowest DIMM.
- The motherboard will support an odd number amount of memory modules. However, to achieve the best memory performance, a balanced memory population is recommended.

Memory Support

DDR5 Memory Support for Intel® Xeon® 6900-Series Processors with P-Cores					
Type	Ranks Per DIMM, Data Width (Stack)	DIMM Capacity (GB)			Speed (MT/s); Voltage (V); Slots per Channel (SPC) and DIMMs per Channel (DPC)
		DRAM Density			1DPC/1SPC
		16 Gb	24 Gb	32 Gb	+1.1 V
RDIMM	1Rx4	32 GB	48 GB	-	6400, 6000, 5600, 5200, 4800 (DDR5-6400 rated RDIMMs only)
	2Rx8	32 GB	48 GB	-	
	2Rx4	64 GB	96 GB	128 GB	
3DS RDIMM	8Rx4	256 GB	-	-	
	4Rx4	-	-	256 GB	
MRDIMM	2Rx8	32 GB	48 GB	-	8800, 8000, 7200 (MRDIMM-8800 only)
	2Rx4	64 GB	96 GB	128 GB	
	4Rx8	64 GB	96 GB	-	
	4Rx4 (2U)	128 GB	-	-	
	4Rx4 (2U)	-	-	256 GB	

Notes:

- Intel Xeon 6900-series processors with P-cores supports 1DPC configuration only
- Intel Xeon 6900-series processors with P-cores supports 1DIMM per processor socket with the following DIMM configuration only: 32 GB 2Rx8

The Intel® Xeon® 6900 series processors with P-cores

Note: DIMM rank mixing is not allowed.

Intel® Xeon® 6900-Series Processors with P-Cores DDR5 Memory Population Table (2 Processors and 24 DIMMs Installed, 1DPC)	
1 Processor DIMM Counts	Memory Population Sequence (1DPC)
1 Processor and 1 DIMM	P1-DIMMA1
1 Processor and 8 DIMMs	P1-DIMMC1/P1-DIMMD1/P1-DIMME1/P1-DIMMF1/P1-DIMMI1/P1-DIMMJ1/P1-DIMMK1/P1-DIMML1
1 Processor and 8 DIMMs	P1-DIMMA1/P1-DIMMB1/P1-DIMMD1/P1-DIMME1/P1-DIMMG1/P1-DIMMH1/P1-DIMMJ1/P1-DIMMK1
1 Processor and 8 DIMMs	P1-DIMMA1/P1-DIMMB1/P1-DIMMC1/P1-DIMMF1/P1-DIMMG1/P1-DIMMH1/P1-DIMMI1/P1-DIMML1
1 Processor and 12 DIMMs	P1-DIMMA1/P1-DIMMB1/P1-DIMMC1/P1-DIMMD1/P1-DIMME1/P1-DIMMF1/P1-DIMMG1/P1-DIMMH1/P1-DIMMI1/P1-DIMMJ1/P1-DIMMK1/P1-DIMML1
2 Processor DIMM Counts (Recommended)	Memory Population Sequence (1DPC)
2 Processors and 2 DIMMs	P1-DIMMA1 P2-DIMMA1
2 Processors and 16 DIMMs	P1-DIMMC1/P1-DIMMD1/P1-DIMME1/P1-DIMMF1/P1-DIMMI1/P1-DIMMJ1/P1-DIMMK1/P1-DIMML1 P2-DIMMC1/P2-DIMMD1/P2-DIMME1/P2-DIMMF1/P2-DIMMI1/P2-DIMMJ1/P2-DIMMK1/P2-DIMML1

Intel® Xeon® 6900-Series Processors with P-Cores DDR5 Memory Population Table (2 Processors and 24 DIMMs Installed, 1DPC)	
2 Processors and 16 DIMMs	P1-DIMMA1/P1-DIMMB1/P1-DIMMD1/P1-DIMME1/P1-DIMMG1/P1-DIMMH1/P1-DIMMJ1/P1-DIMMK1 P2-DIMMA1/P2-DIMMB1/P2-DIMMD1/P2-DIMME1/P2-DIMMG1/P2-DIMMH1/P2-DIMMJ1/P2-DIMMK1
2 Processors and 16 DIMMs	P1-DIMMA1/P1-DIMMB1/P1-DIMMC1/P1-DIMMF1/P1-DIMMG1/P1-DIMMH1/P1-DIMMI1/P1-DIMML1 P2-DIMMA1/P2-DIMMB1/P2-DIMMC1/P2-DIMMF1/P2-DIMMG1/P2-DIMMH1/P2-DIMMI1/P2-DIMML1
2 Processors and 24 DIMMs	P1-DIMMA1/P1-DIMMB1/P1-DIMMC1/P1-DIMMD1/P1-DIMME1/P1-DIMMF1/P1-DIMMG1/P1-DIMMH1/P1-DIMMI1/P1-DIMMJ1/P1-DIMMK1/P1-DIMML1 P2-DIMMA1/P2-DIMMB1/P2-DIMMC1/P2-DIMMD1/P2-DIMME1/P2-DIMMF1/P2-DIMMG1/P2-DIMMH1/P2-DIMMI1/P2-DIMMJ1/P2-DIMMK1/P2-DIMML1

DIMM Installation

Important: To avoid causing any damage to the memory module or the DIMM socket, do not use excessive force when pressing the release tabs on the ends of the DIMM socket. Handle memory modules with care. To avoid ESD-related damage to your memory modules or components, carefully follow all the instructions given in "[Static-Sensitive Devices](#)" on [page 40](#).

1. Insert the desired number of DIMMs into the memory slots based on the recommended DIMM population table earlier in this section.
2. Push the release tabs outwards on both ends of the DIMM slot to unlock it.

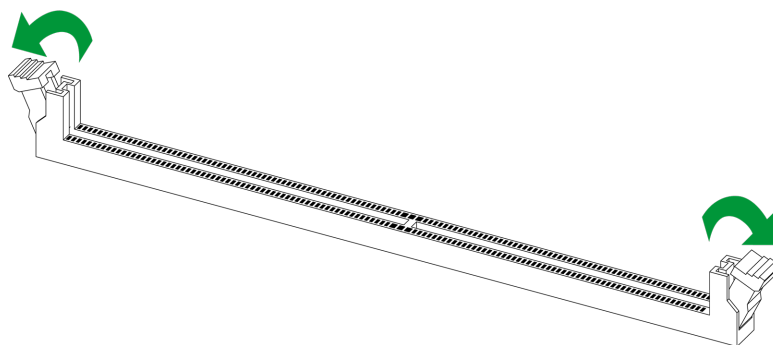

Figure 3-18. Unlocking the DIMM Slot

3. Align the key of the DIMM with the receptive point on the memory slot.

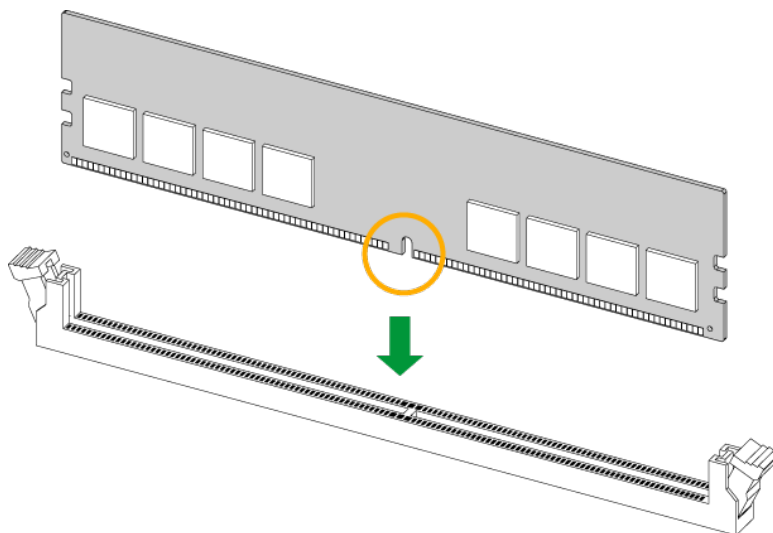

Figure 3-19. Aligning the DIMM Slot with the Receptive Point

4. Align the notches on both ends of the module against the receptive points on the ends of the slot.

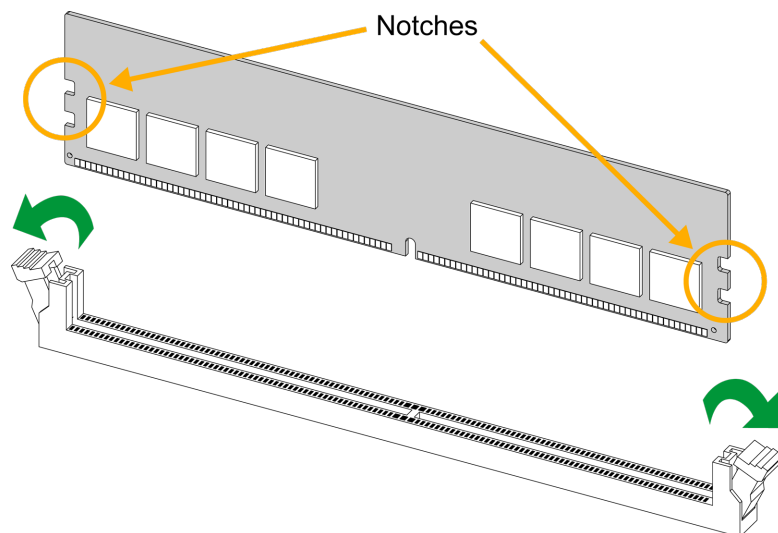

Figure 3-20. Aligning the Notches

5. Press both ends of the module straight down into the slot until the module snaps into place.
6. Press the release tabs to the lock positions to secure the DIMM into the slot.

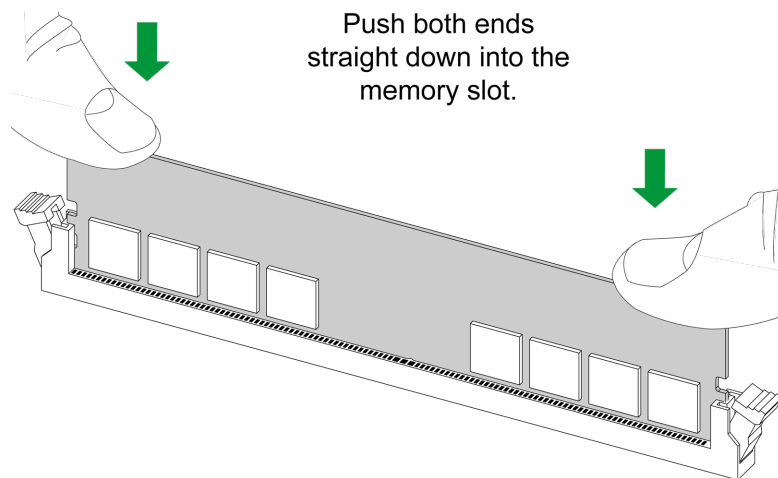

Figure 3-21. Securing the DIMM

For a detailed diagram of the MBD-X14DBG-AP motherboard, see the layout under ["Motherboard Quick Reference"](#) on page 21.

DIMM Removal

Important: To avoid causing any damage to the memory module or the DIMM socket, do not use excessive force when pressing the release tabs on the ends of the DIMM socket. Handle memory modules with care. To avoid ESD-related damage to your memory modules or components, carefully follow all the instructions given in ["Static-Sensitive Devices"](#) on page 40.

Press both release tabs on the ends of the DIMM socket to unlock it. Once the DIMM is loosened, remove it from the memory slot.

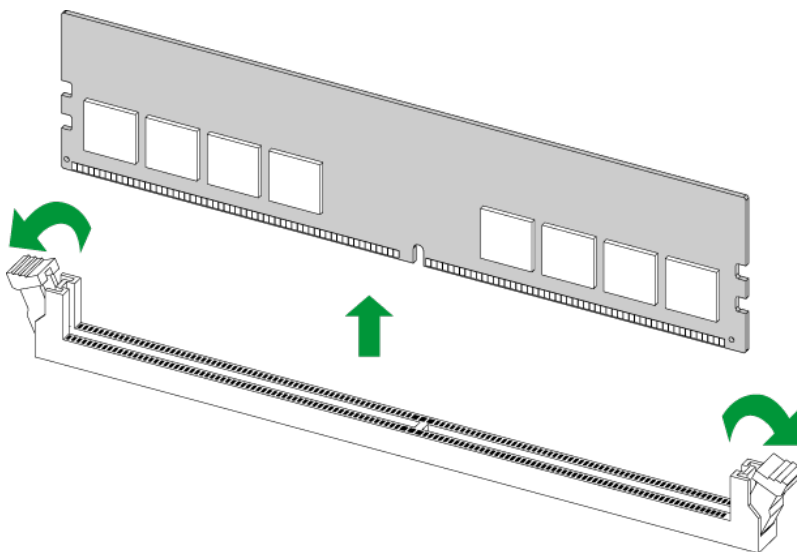

Figure 3-22. Unlocking the DIMM Slot

For a detailed diagram of the MBD-X14DBG-AP motherboard, see the layout under ["Motherboard Quick Reference"](#) on page 21.

3.6 Motherboard Battery Removal and Installation

Battery Removal

To remove the onboard battery, follow the steps below:

1. Power off your system and unplug your power cable.
2. Place the system on a workbench.
3. Remove the top cover from the system.
4. Locate the onboard battery as shown below.
5. Using a tool such as a pen or a small screwdriver, push the battery lock outwards to unlock it. Once unlocked, the battery will pop out from the holder.
6. Remove the battery.

Proper Battery Disposal

Important: Handle used batteries carefully. Do not damage the battery in any way; a damaged battery may release hazardous materials into the environment. Do not discard a used battery in the garbage or a public landfill. Comply with the regulations set up by your local hazardous waste management agency to dispose of your used battery properly.

Battery Installation

To install an onboard battery, follow steps 1 and 2 above and continue below:

Important: When replacing a battery, be sure to only replace it with the same type.

1. Identify the battery's polarity. The positive (+) side should be facing up.
2. Insert the battery into the battery holder and push it down until you hear a click to ensure that the battery is securely locked.

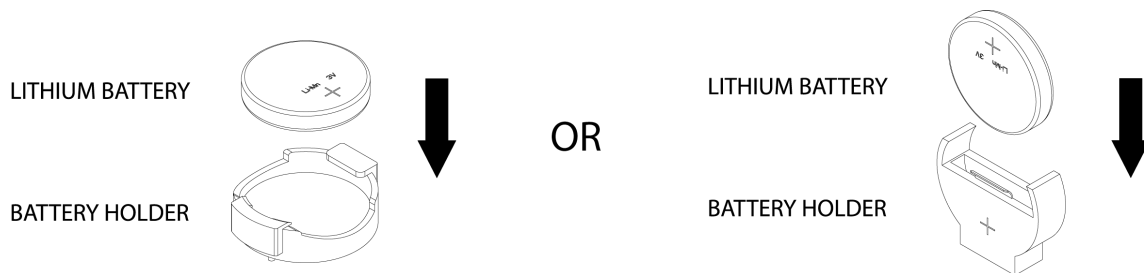

Figure 3-23. Installing a Battery

3.7 Storage Drives

The SYS-422GA-NRT supports a total of eight storage drives, which are mounted in drive carriers and reside within storage drive bays. These drives are hot-swappable and can be removed or replaced without powering down the chassis.

Note: Enterprise-level storage modules are recommended for use in Supermicro servers.

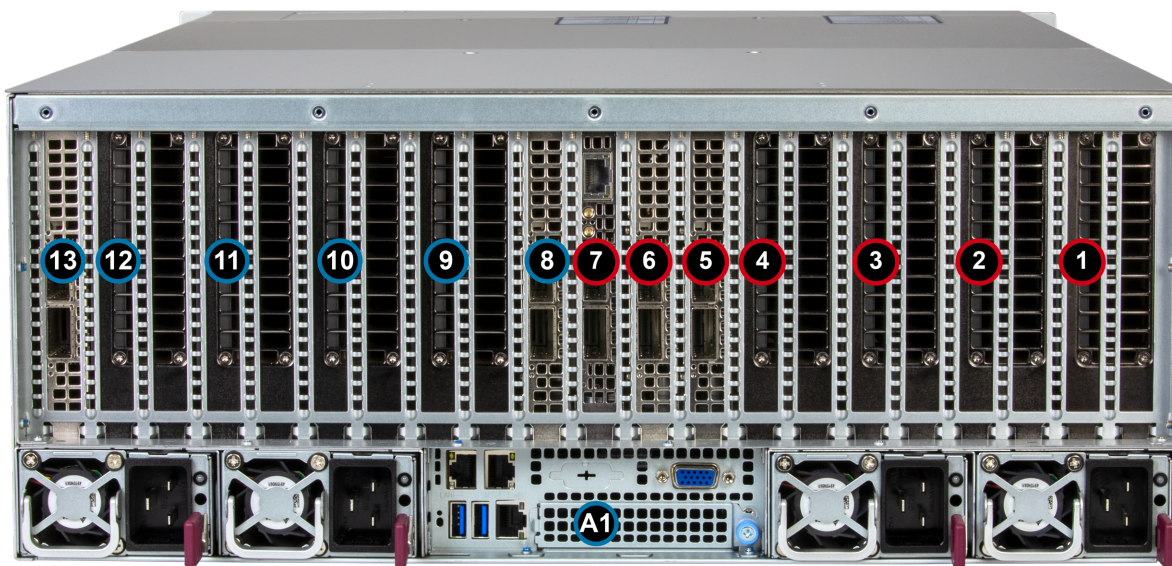

Figure 3-24. Logical Drive Numbers

Expansion Slot Locations (All PCIe 5.0)		
Item	Description	Controlled by
1	x16 slot	CPU1 (via PLX)
2	x16 slot	CPU1 (via PLX)
3	x16 slot	CPU1 (via PLX)
4	x16 slot	CPU1 (via PLX)
5	x16 slot	CPU1 (via PLX)
6	x16 slot	CPU1 (via PLX)
7	x16 slot	CPU1 (direct)
8	x16 slot	CPU2 (via PLX)
9	x16 slot	CPU2 (via PLX)
10	x16 slot	CPU2 (via PLX)
11	x16 slot	CPU2 (via PLX)

Expansion Slot Locations (All PCIe 5.0)

Item	Description	Controlled by
12	x16 slot	CPU2 (via PLX)
13	x16 slot	CPU2 (via PLX)
A1	x16 slot	CPU2 (OCP 3.0)

Important: Except for short periods of time (swapping drives), do not operate the server with the drive carriers removed from the bays, regardless of how many drives are installed, for proper airflow.

Removing a Drive Carrier from the Chassis

1. Press the release button on the drive carrier. This extends the drive carrier handle.
2. Use the handle to pull the drive and its carrier out of the chassis.

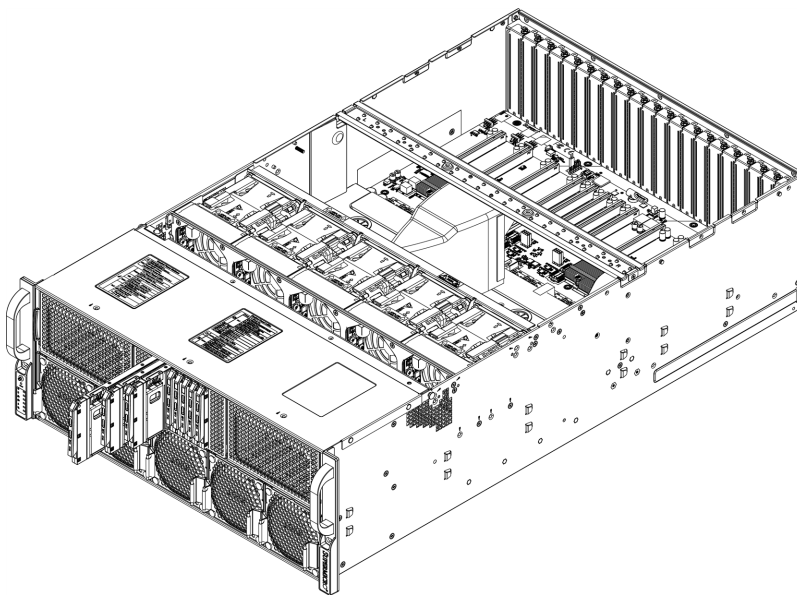

Figure 3-25. Removing a Drive Carrier

Installing a Drive into a Drive Carrier

Important: Use caution when working around the drive backplane. Do not touch the backplane with any metal objects and make sure no ribbon cables touch the backplane or obstruct the holes, which aid in proper airflow.

1. Insert a drive into the carrier with the PCB side facing down and the connector end toward the rear of the carrier.
2. Align the drive in the carrier so that the screw holes of both line up. Note that there are holes in the carrier to aid in correct installation.
3. Secure the drive to the carrier with four screws as illustrated below.
4. Insert the drive carrier into its bay, keeping the carrier oriented so that the drive is on the top of the carrier and the release button is on the right side. When the carrier reaches the rear of the bay, the release handle will retract.
5. Push the handle in until it clicks into its locked position.

Note: Your operating system must have RAID support to enable the hot-plug capability of the drives.

Hot-Swap for NVMe Drives

Supermicro servers support NVMe surprise hot-swap. For even better data security, NVMe orderly hot-swap is recommended. NVMe drives can be ejected and replaced remotely using BMC.

Ejecting a Drive

1. **BMC > Server Health > NVMe SSD**
2. Select Device, Group, and Slot, and click **Eject**. After ejecting, the drive Status LED indicator turns green.
3. Remove the drive.

Note that Device and Group are categorized by the CPLD design architecture.

A Slot is the slot number on which the NVMe drives are mounted.

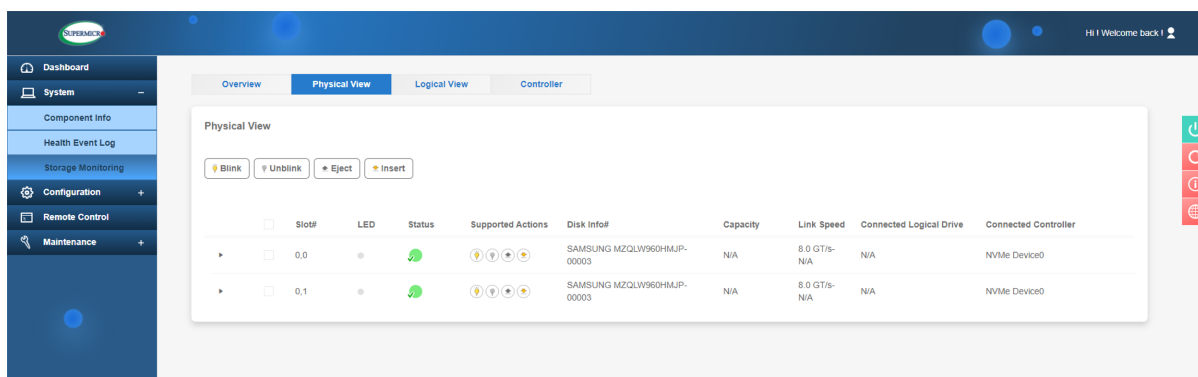

Figure 3-26. BMC Screenshot

Replacing a Drive

1. Insert the replacement drive.
2. **BMC > System > Storage Monitor > Physical View**
3. Select Device, Group, and slot and click **Insert**. The drive Status LED indicator flashes red, then turns off. The Activity LED turns blue.

3.8 System Cooling

Refer to the following sections for information about the cooling capabilities of the SYS-422GA-NRT server.

Fans

The SYS-422GA-NRT server supports ten 8-cm heavy-duty, hot-swappable fans, with five located in the front and five in the middle.

Fans are hot-swappable and can be replaced without powering down the system. The electrical connections are automatically made when a fan is inserted into its slot. Make sure the chassis cover is only off for a short time and makes a good seal when replaced for the cooling air to circulate properly through the system.

Changing a System Fan

1. Determine which fan is failing. If possible, use BMC. If the failed fan is located on the front side, identify it, press the side clip, and replace the fan. If the failed fan is located inside, refer to "[Accessing the System](#)" on page 39. for the steps to remove the chassis cover while the power is on. Examine the fans to determine which one has failed.
2. Press the fan housing lever to unlock the fan from the bracket.
3. While applying pressure to fan housing lever, gently push the fan upwards from underneath the fan housing to remove the fan.

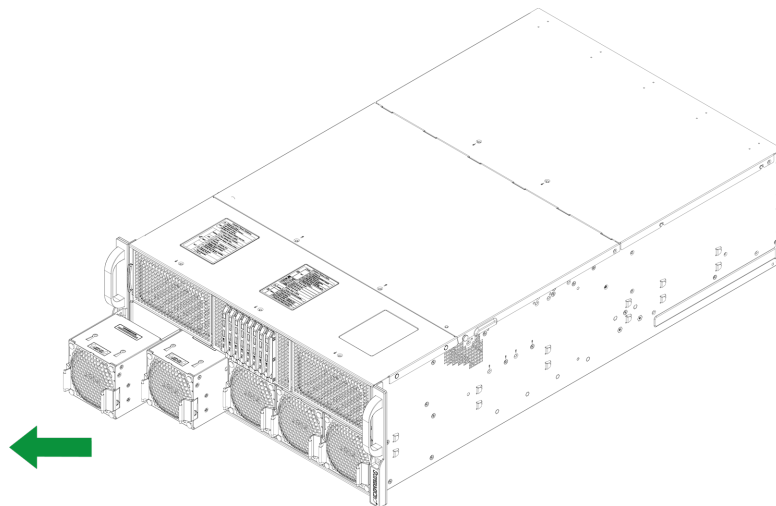

Figure 3-27. Changing a System Fan

4. Place the new fan into the vacant space in the housing. Apply pressure to the top of the new fan to lock it into the fan housing. The new fan should click into place.

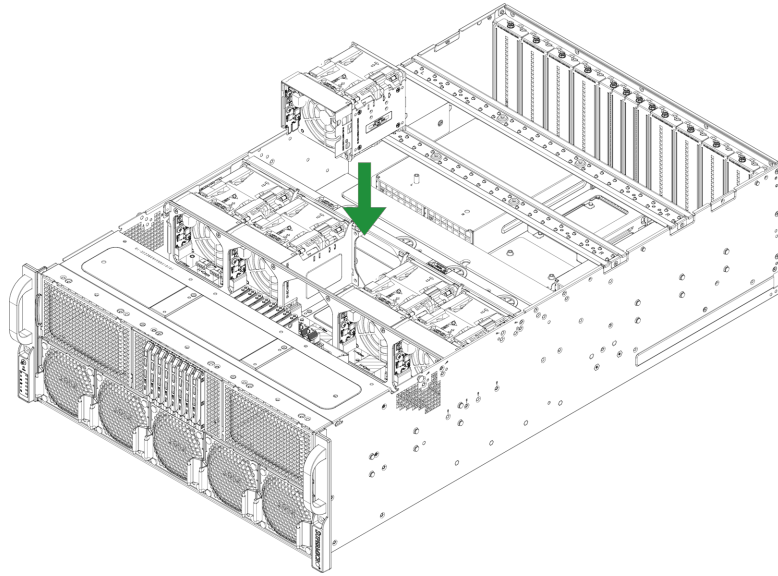

Figure 3-28. Installing a System Fan

5. Verify that the new fan is working properly before replacing the chassis cover.

Air Shrouds

Air shrouds concentrate airflow to maximize fan efficiency.

Installing an Air Shroud

1. Remove power from the system as described in ["Removing Power" on page 1](#).
2. Remove the system from the rack and place on a workbench.
3. Remove the top cover from the system as described in ["Accessing the System" on page 39](#).
4. Align the air shroud with the motherboard.
5. Install the air shroud directly onto the motherboard, pushing down the air shroud down into the system.
6. Return the system to the rack.

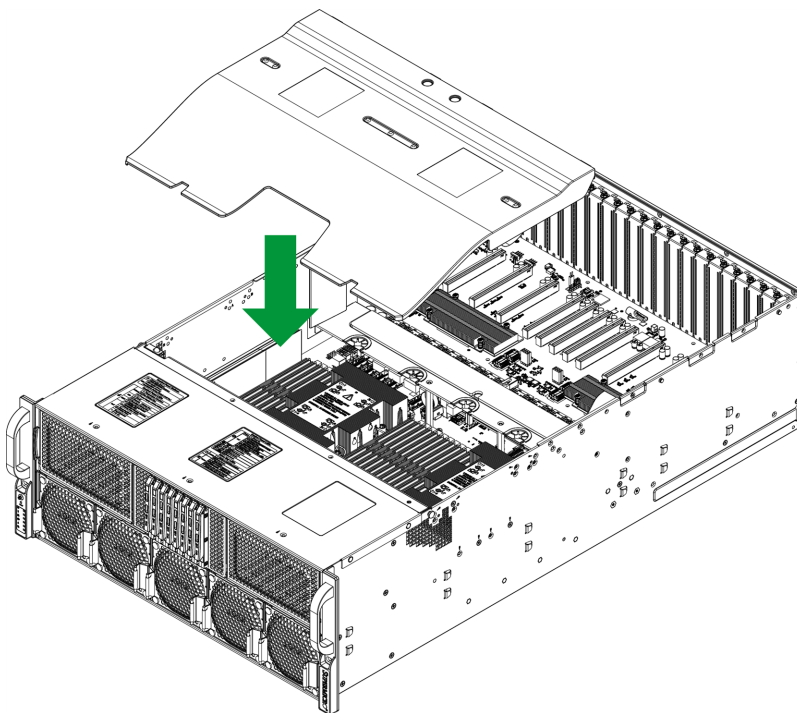

Figure 3-29. Installing an Air Shroud

3.9 GPU and PCIe Cards

The system includes a daughter board for GPU and PCIe expansion capabilities. The figure below for an example of the daughter board in the system.

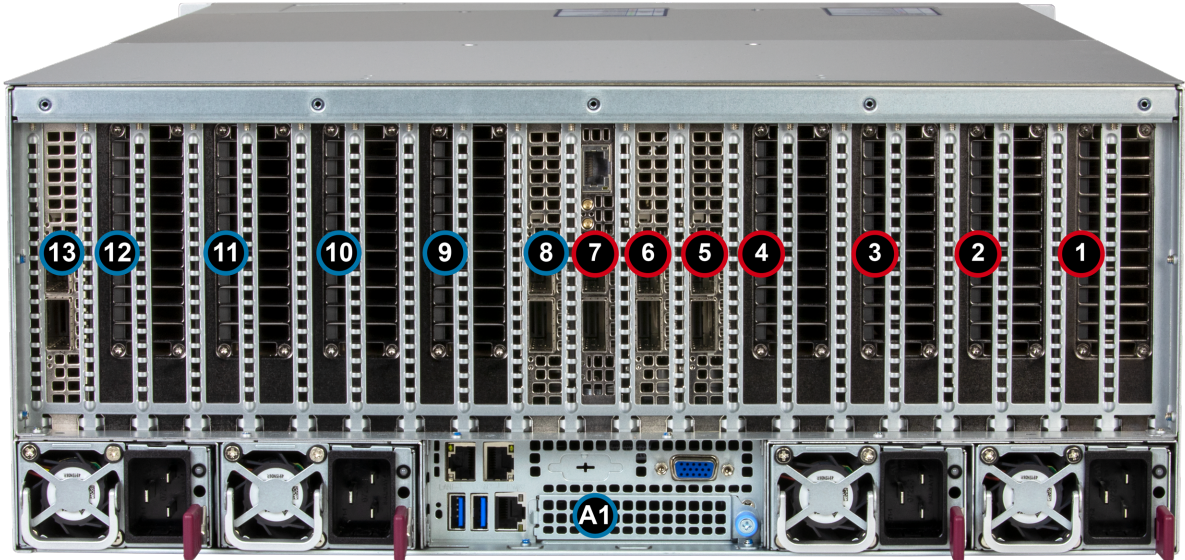

Figure 3-30. GPU and PCIe Card Locations

Expansion Slot Locations (All PCIe 5.0)		
Item	Description	Controlled by
1	x16 slot	CPU1 (via PLX)
2	x16 slot	CPU1 (via PLX)
3	x16 slot	CPU1 (via PLX)
4	x16 slot	CPU1 (via PLX)
5	x16 slot	CPU1 (via PLX)
6	x16 slot	CPU1 (via PLX)
7	x16 slot	CPU1 (direct)
8	x16 slot	CPU2 (via PLX)
9	x16 slot	CPU2 (via PLX)
10	x16 slot	CPU2 (via PLX)
11	x16 slot	CPU2 (via PLX)
12	x16 slot	CPU2 (via PLX)
13	x16 slot	CPU2 (via PLX)
A1	x16 slot	CPU2 (OCP 3.0)

Installing Expansion Cards

1. Power down the system and open the chassis cover.
2. Remove the screw holding the chassis slot shield in place.
3. Insert the expansion card into the daughter board PCIe slot, while aligning the expansion card shield with the slot in the rear of the chassis.
4. Secure the expansion card shield to the chassis using the screw previously removed.

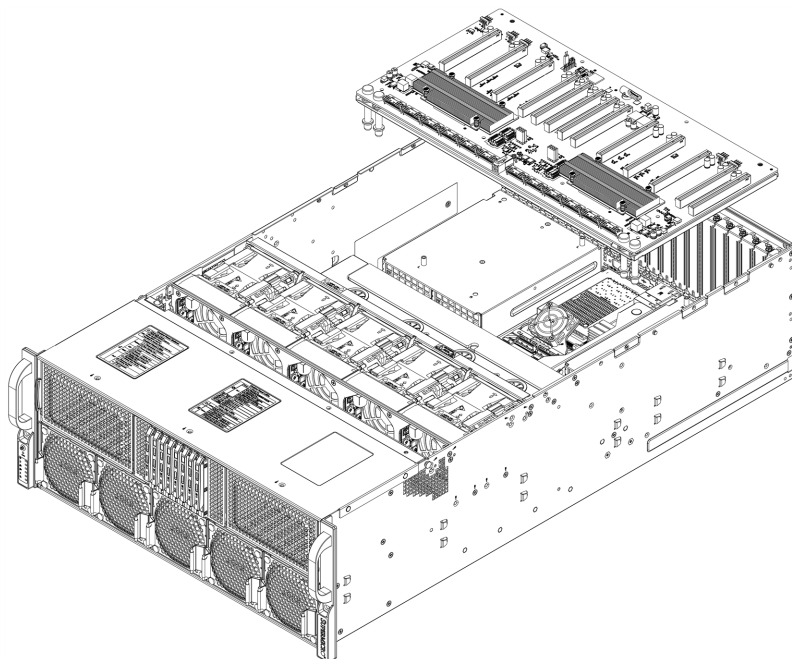

Figure 3-31. Installing the Daughter Board

3.10 Power Supply

The system includes four hot-plug power supply modules. The power supply will automatically sense and operate at an input voltage between 100–240 V. Note that different input voltages will result in different maximum power output levels.

In the event of a power module failure, the other power module will continue to power the system on its own. Failed power supply modules can be replaced without powering down the system. Replacement modules can be ordered directly from Supermicro.

Information LED	
Color, Status	Description
Red, solid	An overheat condition has occurred.
Red, blinking at 1 Hz	Fan failure; check for an inoperative fan.
Red, blinking at 0.25 Hz	Power failure; check for an inoperative power supply.
Red, solid with Power LED blinking green	Fault detected.
Blue and red, blinking at 10 Hz	Recovery mode.
Blue, solid	UID has been activated locally to locate the server in a rack environment.
Blue, blinking at 1 Hz	UID has been activated via BMC to locate the server in a rack environment.
Blue, blinking at 2 Hz	BMC is resetting.
Blue, blinking at 4 Hz	BMC is setting factory defaults.
Blue, blinking at 10 Hz with Power LED blinking green	BMC/BIOS firmware is updating.

Replacing the Power Supply

1. Unplug the AC power cord from the failed power supply module.
2. Push and hold the release tab on the back of the power supply.
3. Grasp the handle of the power supply and pull it out of its bay.
4. Push the new power supply module into the power bay until it clicks into the locked position.
5. Plug the AC power cord back into the power supply module.

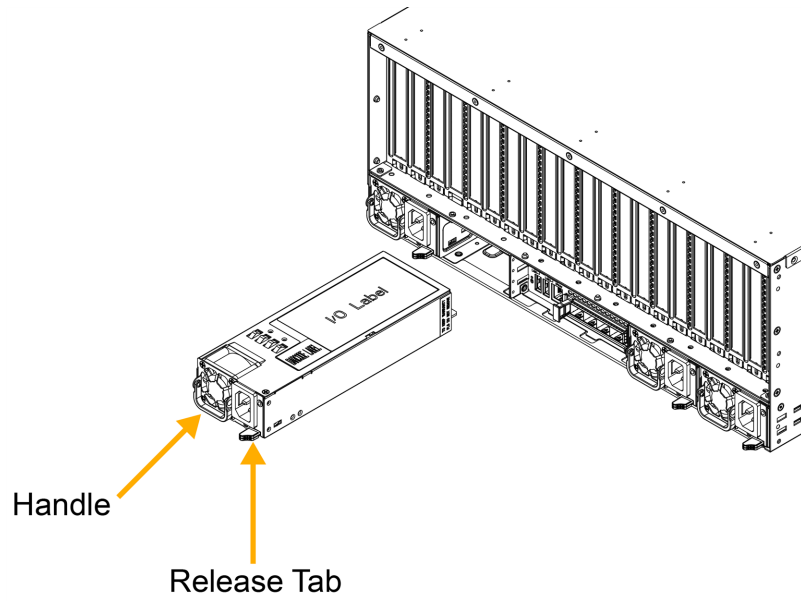

Figure 3-32. Replacing the Power Supply

Chapter 4:

Motherboard Connections, Jumpers, and LEDs

This section describes the connections on the motherboard and provides pinout definitions. Note that depending on how the system is configured, not all connections are required. The LEDs on the motherboard are also described here. A motherboard layout indicating component locations may be found in the ["Introduction" on page 13](#). More detail can be found in the MBD-X14DBG-AP motherboard manual.

Review the ["Standardized Warning Statements for AC Systems" on page 189](#) before installing or removing components.

4.1 Power Supply and Power Connections	72
Power Supply Connections	72
4.2 Headers and Connections	73
Power Supply and Power Connections	73
Control Panel	73
Chassis Intrusion	77
External BMC I ² C Header	77
Fan Headers	78
Liquid Cooling Leakage Sensor Header	78
M.2 Slots	78
MCIO PCIe 5.0 x8 Connectors	79
NC-SI Connection	79
NVMe I ² C Header	79
NVMe I ² C Header	79
PDB CPLD Connector	79
TPM/Port 80 Header	80
VROC RAID Key Header	80
4.3 I/O Connection	82
Advanced I/O Module (AIOM) for I/O Support	82
4.4 Jumper Settings	83
CMOS Clear	83
4.5 LED Indicators	85

M.2 LEDs	85
BMC Heartbeat LED	85
Onboard Power LED	85
Unique Identifier LED (UID)	86

4.1 Power Supply and Power Connections

For information about the power supply and power connections of the SYS-422GA-NRT server, refer to the following content.

Power Supply Connections

As with all computer products, a stable power source is necessary for proper and reliable operation. It is even more important for processors that have high CPU clock rates where noisy power transmission is present.

Important: To provide adequate power to your system, be sure to connect the main power supplies (PSU1/PSU2/PSU3) to the power supply. Failure to do so may void the manufacturer warranty on your power supply and motherboard.

Four power supply connections, located at JPW1–JPW4 on the MBD-X14DBG-AP motherboard, provide main power to your system, and two 8-pin power connections (JPWR5–JPWR6) are used for +12 V devices. All these power connections meet the ATX SSI EPS 12 V specification and must be connected to your power supply to provide adequate power to your system.

For a detailed diagram of the MBD-X14DBG-AP motherboard, see the layout under "[Motherboard Quick Reference](#)" on page 21.

12 V 8-pin Power	
Pin Definitions: Eight Total	
Pin#	Definition
1–4	Ground
5–8	+12 V

4.2 Headers and Connections

For information about the headers on the MBD-X14DBG-AP motherboard, refer to the following content.

Power Supply and Power Connections

For information about the power supply and power connections of the SYS-422GA-NRT server, refer to the following content.

Power Supply Connections

As with all computer products, a stable power source is necessary for proper and reliable operation. It is even more important for processors that have high CPU clock rates where noisy power transmission is present.

Important: To provide adequate power to your system, be sure to connect the main power supplies (PSU1/PSU2/PSU3) to the power supply. Failure to do so may void the manufacturer warranty on your power supply and motherboard.

Four power supply connections, located at JPW1–JPW4 on the MBD-X14DBG-AP motherboard, provide main power to your system, and two 8-pin power connections (JPWR5–JPWR6) are used for +12 V devices. All these power connections meet the ATX SSI EPS 12 V specification and must be connected to your power supply to provide adequate power to your system.

For a detailed diagram of the MBD-X14DBG-AP motherboard, see the layout under "[Motherboard Quick Reference](#)" on page 21.

12 V 8-pin Power	
Pin Definitions: Eight Total	
Pin#	Definition
1–4	Ground
5–8	+12 V

Control Panel

Refer to the following content for information about the front control panel header on the MBD-X14DBG-AP motherboard.

Power Button

The Power Button connection is located on pins 1 and 2 of JF1 on the MBD-X14DBG-AP motherboard. Momentarily contacting both pins will power on/off the system. This button can also be configured to function as a suspend button (with a setting in the BIOS). To turn off the power when the system is in suspend mode, press the button for four seconds or longer.

For a detailed diagram of the MBD-X14DBG-AP motherboard, see the layout under ["Motherboard Quick Reference" on page 21](#).

Power Button	
Pin Definitions (JF1)	
Pin#	Definition
1	Signal
2	GND

Reset Button

The Reset Button connection is located on pins 3 and 4 of JF1 on the MBD-X14DBG-AP motherboard. Attach it to a hardware reset switch on the computer case to reset the system.

For a detailed diagram of the MBD-X14DBG-AP motherboard, see the layout under ["Motherboard Quick Reference" on page 21](#).

Reset Button	
Pin Definitions (JF1)	
Pin#	Definition
3	Reset
4	GND

Power Fail LED

The Power Fail LED connection is located on pins 5 and 6 of JF1 on the MBD-X14DBG-AP motherboard.

For a detailed diagram of the MBD-X14DBG-AP motherboard, see the layout under ["Motherboard Quick Reference" on page 21](#).

Power Fail LED	
Pin Definitions (JF1)	
Pin#	Definition
5	+3.3 V
6	PWR Supply Fail

UID LED

The unit identifier LED connection is located on pin 3 of JFP1 on the MBD-X14DBG-AP motherboard.

For a detailed diagram of the MBD-X14DBG-AP motherboard, see the layout under ["Motherboard Quick Reference" on page 21](#).

Fail LED (Information LED for OH/FF/PF)

The Fail LED (Information LED for OH/Fan Fail/PWR Fail) connection, located on pin 4 of JFP1, provides warnings of overheating, power failure, or fan failure for the system.

For a detailed diagram of the MBD-X14DBG-AP motherboard, see the layout under ["Motherboard Quick Reference" on page 21](#).

Fail LED (Information LED) (OH/Fan Fail/PWR Fail)	
LED States	
Status	Description
Solid red (on)	An overheat condition has occurred.
Blinking red (1 Hz)	Fan failure: check for an inoperative fan.
Blinking red (0.25 Hz)	Power failure: check for a non-operational power supply.
Blinking red (10 Hz) (FP red LED)	CPLD recovery mode error(s).
Solid blue	UID has been activated locally. Use this function to locate a unit in the system that might be in need of service.
Blinking blue (1 Hz)	Local UID has been activated locally on. Use this function to identify a unit that might be in need of service.
BIOS/BMC blinking blue (10 Hz)	BIOS/BMC: recovery and/or update in progress.
Red Info LED blinking (10 Hz) and MB UID LED blue blinking (10 Hz)	CPLD: recovery and/or update in progress.

NIC1/NIC2 (LAN1/LAN2)

The Network Interface Controller (NIC) LED connection for LAN port 1 is located on pins 11 and 12 of JF1 on the MBD-X14DBG-AP motherboard, and LAN port 2 is on pins 9 and 10. Attach the NIC LED cables here to display network activity.

For a detailed diagram of the MBD-X14DBG-AP motherboard, see the layout under ["Motherboard Quick Reference" on page 21](#).

LAN1/LAN2 LED	
Pin Definitions (JF1)	
Pin#	Definition
9	VCC
10	NIC2 Link/Active LED
11	VCC
12	NIC1 Link/Active LED

UID Switch/HDD LED

The UID Button/HDD LED connection is located on pins 13 and 14 of JF1 on the MBD-X14DBG-AP motherboard. Attach a cable to pin 13 to use the UID button. Attach a cable to pin 14 to show storage drive activity status.

For a detailed diagram of the MBD-X14DBG-AP motherboard, see the layout under ["Motherboard Quick Reference" on page 21](#).

UID Button/HDD LED	
Pin Definitions (JF1)	
Pin#	Definition
13	+3.3 V Standby/UID Button
14	HDD Activity

Power LED

The Power LED connection is located on pins 15 and 16 of JF1 on the MBD-X14DBG-AP motherboard.

For a detailed diagram of the MBD-X14DBG-AP motherboard, see the layout under ["Motherboard Quick Reference" on page 21](#).

Power LED	
Pin Definitions (JF1)	
Pin#	Definition
15	+3.3 V
16	PWR LED

NMI Button

The non-maskable interrupt (NMI) button header is located on pins 19 and 20 of JF1 on the MBD-X14DBG-AP motherboard.

For a detailed diagram of the MBD-X14DBG-AP motherboard, see the layout under ["Motherboard Quick Reference" on page 21](#).

NMI Button	
Pin Definitions (JF1)	
Pin#	Definition
19	Control
20	GND

Chassis Intrusion

A Chassis Intrusion header is located at JL1 on the MBD-X14DBG-AP motherboard. Attach the appropriate cable from the chassis to inform you when the chassis is opened.

For a detailed diagram of the MBD-X14DBG-AP motherboard, see the layout under ["Motherboard Quick Reference" on page 21](#).

Chassis Intrusion	
Pin Definitions: Two Total	
Pin#	Definition
1	Intrusion Input
2	GND

External BMC I²C Header

A System Management Bus header for the BMC is located at JIPMB1 on the MBD-X14DBG-AP motherboard. Connect the appropriate cable here to use the IPMB I²C connection on your system.

For a detailed diagram of the MBD-X14DBG-AP motherboard, see the layout under ["Motherboard Quick Reference" on page 21](#).

Fan Headers

There are five 4-pin fan headers (FAN1–FAN4, FANSTBY) on the MBD-X14DBG-AP motherboard. All the 4-pin fan headers are backwards compatible with the traditional 3-pin fans. However, fan speed control is available for all fans except FANSTBY by Thermal Management via the IPMI 2.0 interface.

4-pin Fan Header	
Pin Definitions: Four Total	
Pin#	Definition
1	GND (Black)
2	+12 V (Red)
3	Tachometer
4	PWM Control

Liquid Cooling Leakage Sensor Header

Two liquid cooling leakage sensor headers JLCS1 and JLCS2 are located on the MBD-X14DBG-AP motherboard. This header is reserved for liquid cooling support in systems. Liquid cooling leakage sensor headers are used to detect leakage of the coolant used in your liquid cooling system.

For a detailed diagram of the MBD-X14DBG-AP motherboard, see the layout under ["Motherboard Quick Reference" on page 21](#).

M.2 Slots

Two M.2 M-Key slots are located at JM2_1 and JM2_2 on the MBD-X14DBG-AP motherboard. M.2 was formerly known as Next Generation Form Factor (NGFF) and serves to replace mini PCIe. M.2 allows for a variety of card sizes, increased functionality, and spatial efficiency. The M.2 M-Key slots on the motherboard support PCIe 5.0 x2 devices in a 2280/22110 form factor.

For a detailed diagram of the MBD-X14DBG-AP motherboard, see the layout under ["Motherboard Quick Reference" on page 21](#).

MCIO PCIe 5.0 x8 Connectors

Mini Cool Edge IO (MCIO) PCIe 5.0 x8 connectors are located at JMCI0 1A, 1B, 2A, 2B, 3A, 3B, 4A, 4B, 5A, 5B, 6A, 6B, 8A, 8B, 9A, 9B, 10A, 10B, 11A, and 11B on the MBD-X14DBG-AP motherboard.

For a detailed diagram of the MBD-X14DBG-AP motherboard, see the layout under "[Motherboard Quick Reference](#)" on page 21.

NC-SI Connection

The Network Controller Sideband Interface (NC-SI) connection is located at JNCSI1 on the MBD-X14DBG-AP motherboard. This connection is used to connect a Network Interface Card (NIC) to the motherboard to allow the onboard Baseboard Management Controller (BMC) to communicate with a network.

Note: For detailed instructions on how to configure Network Interface Card (NIC) settings, refer to the Network Interface Card Configuration User's Guide posted on the web page under the link: <https://www.supermicro.com/support/manuals>.

For a detailed diagram of the MBD-X14DBG-AP motherboard, see the layout under "[Motherboard Quick Reference](#)" on page 21.

NVMe I²C Header

Connector JNVI2C1 on the MBD-X14DBG-AP motherboard is a management header for the Supermicro AOC NVMe PCIe peripheral card. Connect the I²C cable to this connector.

For a detailed diagram of the MBD-X14DBG-AP motherboard, see the layout under "[Motherboard Quick Reference](#)" on page 21.

NVMe I²C Header

Connector JBPNI2C1 on the MBD-X14DBG-AP motherboard is a management header for the Supermicro AOC NVMe PCIe peripheral card. Connect the I²C cable to this connector.

For a detailed diagram of the MBD-X14DBG-AP motherboard, see the layout under "[Motherboard Quick Reference](#)" on page 21.

PDB CPLD Connector

JPDB1 provides access to the motherboard complex programmable logic device (CPLD).

TPM/Port 80 Header

The JTPM1 header on the MBD-X14DBG-AP motherboard is used to connect a Trusted Platform Module (TPM)/Port 80, which is available from Supermicro (optional). A TPM/Port 80 connector is a security device that supports encryption and authentication in storage drives. It allows the motherboard to deny access if the TPM associated with the storage drive is not installed in the system. Information on the TPM is available at the following page:

https://www.supermicro.com/manuals/other/AOM-TPM-9670V_9670H_X12_H12.pdf

For a detailed diagram of the MBD-X14DBG-AP motherboard, see the layout under "Motherboard Quick Reference" on page 21.

Trusted Platform Module Header			
Pin Definitions: 10 Total			
Pin#	Definition	Pin#	Definition
1	+3.3 V	2	SPI_CS#
3	RESET#	4	SPI_MISO
5	SPI_CLK	6	GND
7	SPI_MOSI	8	No Connection
9	+1.8 V Standby	10	SPI_IRQ#

VROC RAID Key Header

A VROC RAID Key header is located at JRK1 on the MBD-X14DBG-AP motherboard. Install a VROC RAID key on JRK1 for NVMe RAID support as shown in the illustration below.

For a detailed diagram of the MBD-X14DBG-AP motherboard, see the layout under "Motherboard Quick Reference" on page 21.

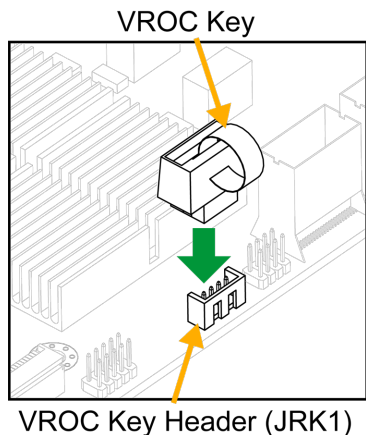

Intel VROC Key	
Pin Definitions:	
Four Total	
Pin#	Definition
1	GND
2	+3.3 V Standby
3	GND
4	CPU RAID Key

Note: Images displayed are for illustrative purposes only. The components installed in your system may or may not look exactly the same as the graphics shown in the manual.

Note: For detailed instructions on how to configure VROC RAID settings, refer to the VROC RAID Configuration User's Guide posted on the web page under the following link: <https://www.supermicro.com/support/manuals>.

4.3 I/O Connection

I/O Connection	
#	Description
1	JAIOM1

Advanced I/O Module (AIOM) for I/O Support

A Supermicro proprietary Advanced I/O Module (AIOM) PCIe 5.0 x16 connector used for an add-on module is located at JAIOM1 (P2-AIOM PCIe 5.0 x16). JAIOM1 is supported by processor 2. This AIOM connector provides input/output connections on the rear side of your system.

For a detailed diagram of the MBD-X14DBG-AP motherboard, see the layout under ["Motherboard Quick Reference"](#) on page 21.

4.4 Jumper Settings

To modify the operation of the motherboard, jumpers can be used to choose between optional settings. Jumpers create shorts between two pins to change the function of the connector. Pin 1 is identified with a square solder pad on the printed circuit board. See the diagram below for an example of jumping pins 1 and 2. Refer to the motherboard layout page for jumper locations.

Note: On two-pin jumpers, "Closed" means the jumper is on and "Open" means the jumper is off the pins.

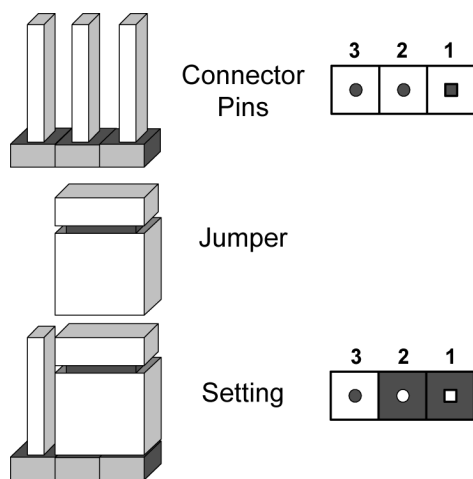

Figure 4-1. Jumping Connector Pins

CMOS Clear

JBT1 on the MBD-X14DBG-AP motherboard is used to clear CMOS, which will also clear any passwords. Instead of pins, this jumper consists of contact pads to prevent accidentally clearing the contents of CMOS.

For a detailed diagram of the MBD-X14DBG-AP motherboard, see the layout under ["Motherboard Quick Reference" on page 21](#).



1. First power down the system and unplug the power cord(s).
2. Remove the cover of the chassis to access the motherboard.
3. Remove the onboard battery from the motherboard.

4. Short the CMOS pads, JBT1, with a metal object such as a small screwdriver for at least four seconds.

Note: Clearing CMOS will also clear all passwords.

5. Remove the screwdriver (or shorting device).
6. Replace the cover, reconnect the power cord(s), and power on the system.

4.5 LED Indicators

For information about the LED indicators on the SYS-422GA-NRT server, refer to the following content.

M.2 LEDs

M.2 LEDs are located at LED1 and LED2 on the MBD-X14DBG-AP motherboard. When these LEDs are blinking, the M.2 devices are functioning normally.

For a detailed diagram of the MBD-X14DBG-AP motherboard, see the layout under ["Motherboard Quick Reference" on page 21](#).

M.2 LED State	
LED Color	Definition
Green: Blinking	Device Working

BMC Heartbeat LED

A BMC Heartbeat LED is located at LEDBMC on the MBD-X14DBG-AP motherboard. When this LED is blinking, the BMC is functioning normally.

For a detailed diagram of the MBD-X14DBG-AP motherboard, see the layout under ["Motherboard Quick Reference" on page 21](#).

BMC Heartbeat LED Indicator	
LED Color	Definition
Green: Blinking	BMC Normal

Onboard Power LED

The Onboard Power LED is located at LEDPWR on the MBD-X14DBG-AP motherboard. When this LED is on, the system is on. Be sure to turn off the system and unplug the power cord before removing or installing components.

For a detailed diagram of the MBD-X14DBG-AP motherboard, see the layout under ["Motherboard Quick Reference" on page 21](#).

Onboard Power LED Indicator	
LED Color	Definition
Off	System Power Off (power cable not connected)
Green	System Power On

Unique Identifier LED (UID)

The front UID LED indicator is located UID_LED on the MBD-X14DBG-AP motherboard. This UID indicator provides easy identification of a system that may need services.

For a detailed diagram of the MBD-X14DBG-AP motherboard, see the layout under ["Motherboard Quick Reference"](#) on page 21.

UID LED	
LED Indicator	
LED Color	Definitions
Blue: On	System Identified

Chapter 5:

Software

After the SYS-422GA-NRT server has been installed, you can install the Operating System (OS), configure RAID settings, and install the drivers.

5.1 Microsoft Windows OS Installation	88
Installing the OS	88
5.2 Driver Installation	90
5.3 BMC	91
BMC ADMIN User Password	91
5.4 Logging into the BMC	92

5.1 Microsoft Windows OS Installation

If you will be using RAID, you must configure RAID settings before installing the Windows OS and the RAID driver. Refer to the RAID Configuration User Guides posted on our website at <https://www.supermicro.com/support/manuals>.

Installing the OS

1. Create a method to access the Microsoft Windows installation ISO file. That can be a USB flash or media drive, or the BMC KVM console.
2. Retrieve the proper drivers. Go to the Supermicro web page for your motherboard and click on "Download the Latest Drivers and Utilities," select the proper driver, and copy it to a USB flash drive.
3. Boot from a bootable device with Windows OS installation. You can see a bootable device list by pressing <F11> during the system bootup.

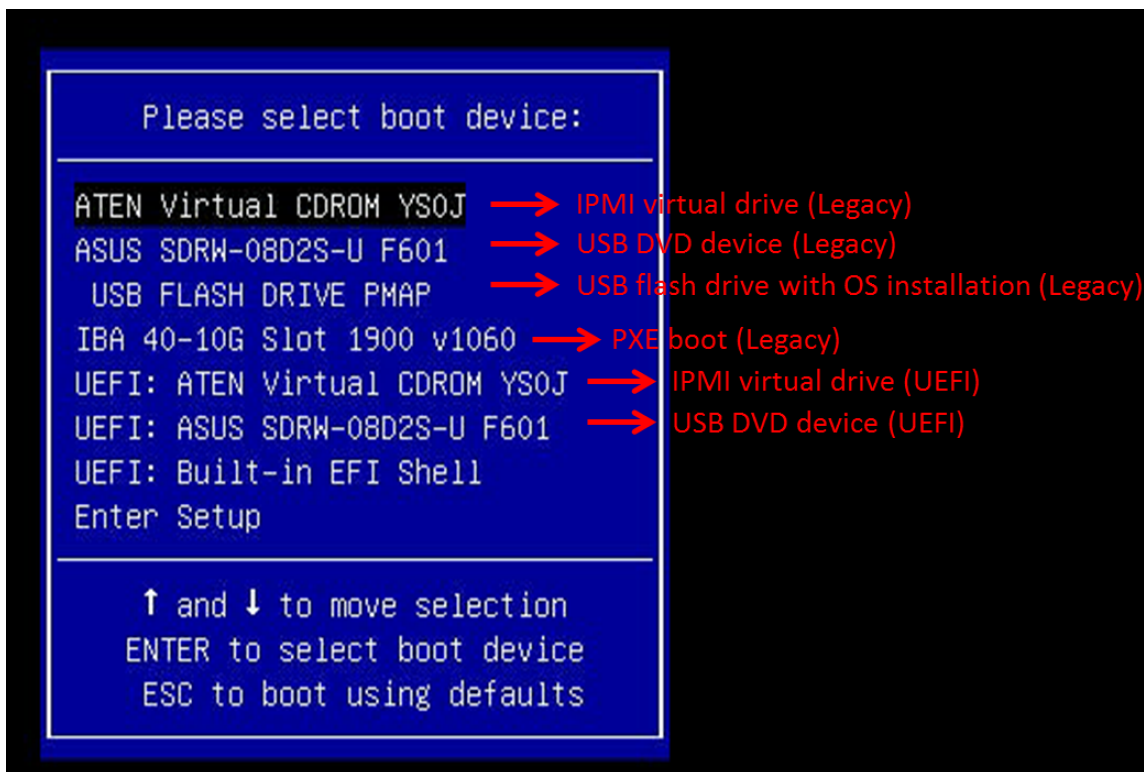

Figure 5-1. Selecting the Boot Device

4. During Windows Setup, continue to the dialog box where you select the drives on which to install Windows. If the disk you want to use is not listed, click on the "Load driver" link at the bottom left corner.

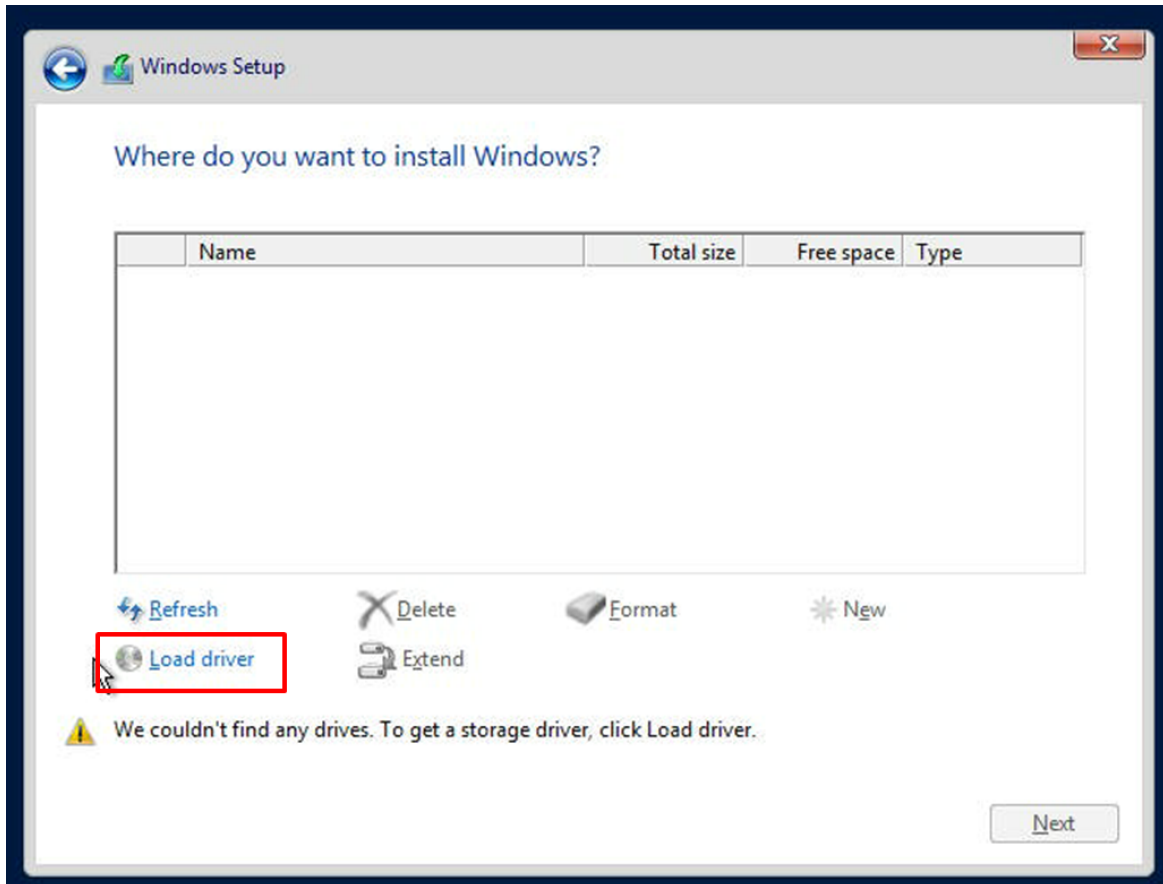

Figure 5-2. Loading the Driver Link

To load the driver, browse the USB flash drive for the proper driver files.

5. Once all devices are specified, continue with the installation.
6. After the Windows OS installation has completed, the system will automatically reboot multiple times for system updates.

5.2 Driver Installation

The Supermicro website contains drivers and utilities for your system at the following page:

<https://www.supermicro.com/wdl>.

Some of these drivers and utilities must be installed, such as the chipset driver. After accessing the website, go into the CDR_Images (in the parent directory of the above link) and locate the ISO file for your motherboard. Download this file to a USB flash or media drive. You may also use a utility to extract the ISO file if preferred.

Another option is to go to the Supermicro website at <https://www.supermicro.com>. Find the product page for your motherboard and download the latest drivers and utilities. Insert the flash drive or disk, and the screenshot shown below should appear.

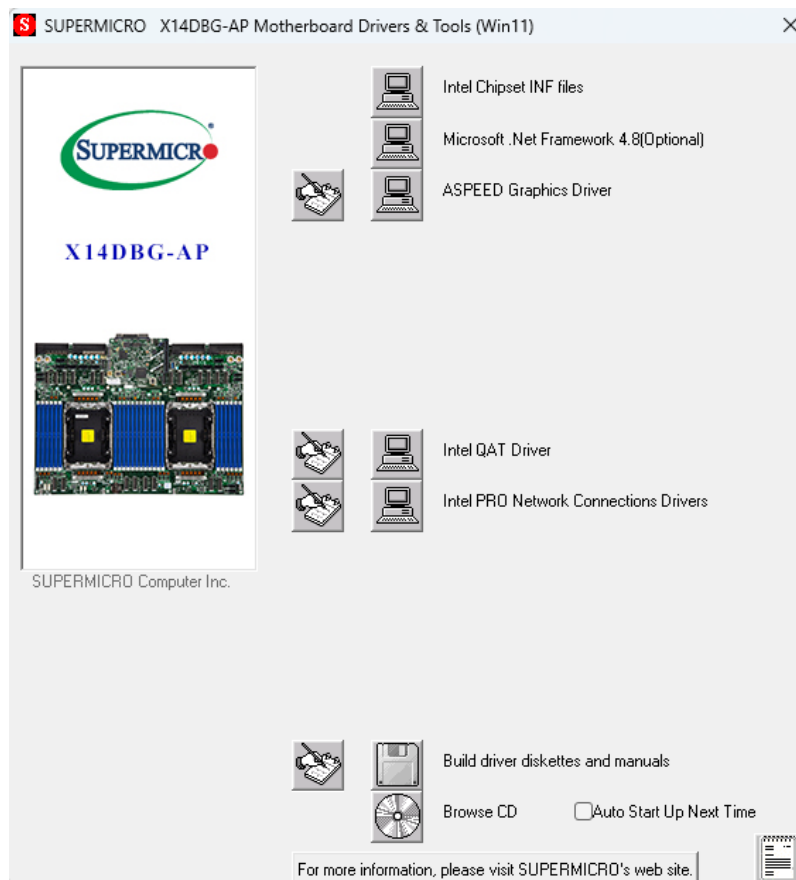

Figure 5-3. Driver & Tools Installation Screen

Note: Click the icons showing a hand writing on paper to view the readme files for each item. Click the computer icons to the right of these items to install each item (from top to bottom) one at a time. After installing each item, you must reboot the system before moving on to the next item on the list. The bottom icon with a CD on it allows you to view the entire contents.

5.3 BMC

The MBD-X14DBG-AP motherboard provides remote access, monitoring, and management through the baseboard management controller (BMC) and other management controllers distributed among different system modules. There are several BIOS settings that are related to BMC. For general documentation and information on BMC, visit our website at the following page:

<https://www.supermicro.com/en/solutions/management-software/bmc-resources>

BMC ADMIN User Password

For security, each system is assigned a unique default BMC password for the ADMIN user. The password can be found on a sticker on the motherboard and a sticker on the chassis, for Supermicro chassis. The sticker also displays the BMC MAC address. If necessary, the password can be reset using the Supermicro IPMICFG tool.



Figure 5-4. BMC Password Label

5.4 Logging into the BMC

Supermicro ships standard products with a unique password for the BMC ADMIN user. This password can be found on a label on the motherboard.

When logging in to the BMC for the first time, use the unique password provided by Supermicro to log in. You can change the unique password to a user name and password of your choice for subsequent logins.

For more information regarding BMC passwords, visit our website at the following page:

https://www.supermicro.com/en/support/BMC_Unique_Password

Chapter 6:

Optional Components

This chapter describes alternate configurations and optional system components for the SYS-422GA-NRT server.

6.1 TPM Security Module	94
6.2 HBA Card	95
6.3 RAID Cards	96
6.4 Cable Management Arm	97
Installing the Cable Management Arm	98
Removing the Cable Management Arm	99
6.5 Intel Virtual RAID on CPU (VROC)	100
Requirements and Restrictions	100
Additional Information	100
Hardware Key	101
Configuring Intel VMD	101
Creating NVMe RAID Configurations	105

6.1 TPM Security Module

This is an SPI-capable TPM 2.0 with Infineon 9672 controller.

The JTPM1 header is used to connect a Trusted Platform Module (TPM). A TPM is a security device that supports encryption and authentication in storage drives. It enables the MBD-X14DBG-AP motherboard to deny access if the TPM associated with the storage drive is not installed in the SYS-422GA-NRT server.

For details and installation procedures, refer to the following page:

<https://www.supermicro.com/en/products/accessories/addon/AOM-TPM-9672V.php>

- AOM-TPM-9672V (TCG 2.0)

6.2 HBA Card

This is a 12 Gb/s, multi-port SAS PCIe Gen 4.0 internal Host Bus Adapter (HBA) card.

The Supermicro HBA AOC-S3816L-L16iT features 16 internal SAS connectors, while the AOC-S3808L-L8iT features eight internal SAS connectors. Both are designed for high-performance storage connectivity.

These cards use Broadcom's 3816 and 3808 I/O processors for optimum performance with PCI Express Gen 4.0 host interface for increased bandwidth.

Each Add-On-Card supports up to 122 devices as HBA in IT mode via the expander backplane.

6.3 RAID Cards

These are Supermicro 12 Gb/s, multi-port PCIe Gen 4.0 RAID adapter cards.

The low-profile AOC-S3908L-H8iR RAID card features eight internal SAS connectors and the AOC-S3916L-H16iR features 16 internal SAS connectors. Both offer high-performance storage connectivity. These RAID cards are built on the Broadcom SAS IC technology and MegaRAID technology to address the growing demand for increased data throughput and scalability requirements across the enterprise-class server platforms.

With high-performance RAID architecture, including hardware RAID 5 and 6, these RAID controller cards support high capacity storage applications. They deliver cost-effective storage solutions using drives and maximum performance and reliability with SAS drives. Using expander backplanes, they support up to 16, 32, and 240 drives (depending on SKU) with RAID 0, 1, 5, 6, 10, 50, and 60.

6.4 Cable Management Arm

The SYS-422GA-NRT server supports a cable management arm (CMA), which keeps the rear cables organized and clear of the rail mechanisms when the system is extended out the front of the rack for maintenance.

The CMA attaches to the rack mounting rails using four connectors. They are labeled as connectors 1, 2, 3, and 4.

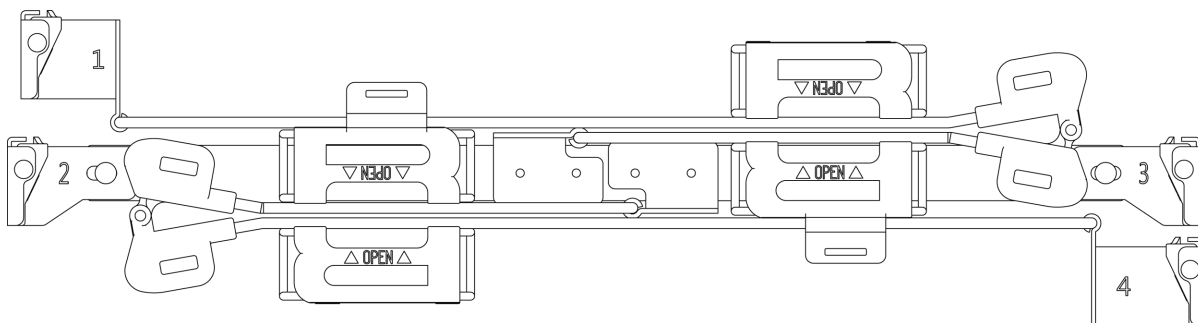

Figure 6-1. Cable Management Arm

Cable Arm Details		
Optional Part	Part Number	Description
Cable Arm	MCP-290-00168-0N	7.5" deep cable arm
Rail Set	MCP-290-11901-0N	41.2" rails (optimized for 1200-mm deep racks)

Installing the Cable Management Arm

1. Slide CMA connector #1 forward onto the two posts on the rear of the right inner rail (right side when viewed from the front). It snaps into place.
2. Slide CMA connector #2 forward onto the two posts on the rear of the right middle rail. It snaps into place.

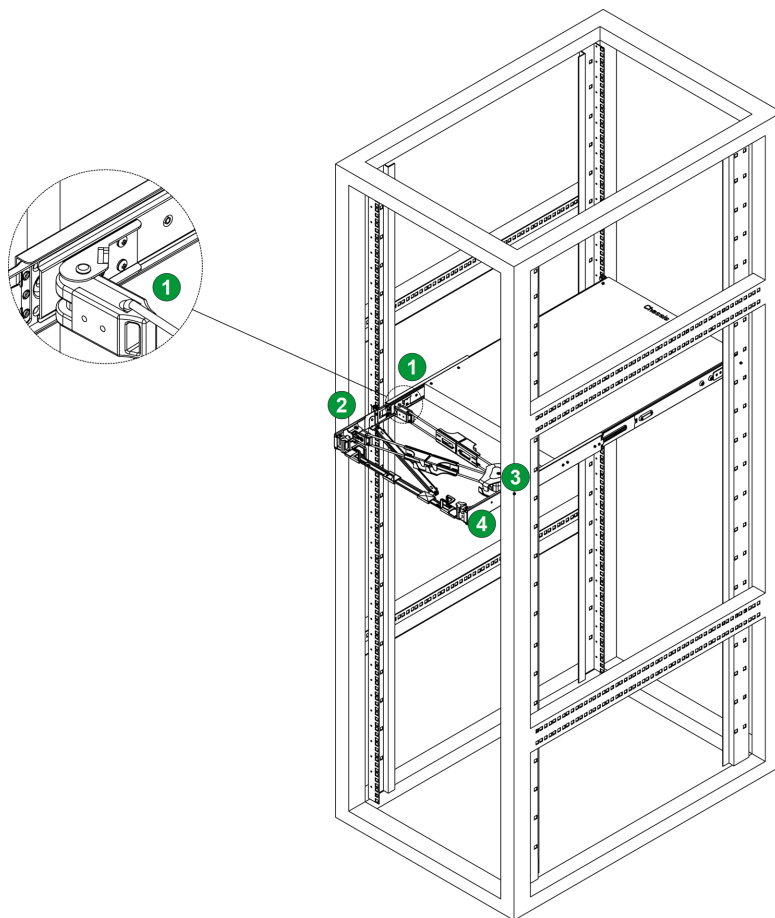

Figure 6-2. Installing the Connectors

3. Slide CMA connector #3 forward onto the two posts on the rear of the left middle rail. It snaps into place.
4. For CMA connector #4, align the metal tabs with the slots on the rear of the left outer rail and push it forward. It snaps into place.
5. Route the cables through the holding brackets, leaving enough slack.

Removing the Cable Management Arm

1. Remove cables from the CMA.
2. For CMA connector #4, pull the metal release tab toward the center of the rack and slide the connector toward the rear to release it.
3. For CMA connectors #3, #2, and #1, depress the front edge of the yellow plastic rocker lock and slide the connector toward the rear to release it.

6.5 Intel Virtual RAID on CPU (VROC)

Intel® Virtual RAID on CPU (Intel VROC) is an enterprise RAID solution for NVMe SSDs directly attached to Intel Xeon Scalable processors. Intel Volume Management Device (VMD) is an integrated controller inside the CPU PCIe root complex.

- A single processor supports up to 12 NVMe SSDs and up to 6 RAID arrays.
- A dual processor system supports up to 24 NVMe SSDs and 12 RAID arrays.

Stripe sizes are 4K, 8K, 16K, 32K, 64K, 128K.

Requirements and Restrictions

- *Intel VROC is only available when the system is configured for UEFI boot mode.*
- To enable the **mdadm** command and support for RSTe, install the patch from
 - Linux: <https://downloadcenter.intel.com/download/28158/Intel-Virtual-RAID-on-CPU-Intel-VROC-and-Intel-Rapid-Storage-Technology-enterprise-Intel-RSTe-Driver-for-Linux->
 - Windows: <https://downloadcenter.intel.com/download/28108/Intel-Virtual-RAID-on-CPU-Intel-VROC-and-Intel-Rapid-Storage-Technology-enterprise-Intel-RSTe-Driver-for-Windows->
- To enable Intel VROC, a hardware key must be inserted on the motherboard, and the appropriate processor's Virtual Management Devices must be enabled in the BIOS setup.
- It is possible to enable Intel VROC without a hardware key installed, but only RAID0 will be enabled.
- Intel VROC is not compatible with secure boot. This feature must be disabled.
- When creating bootable OS RAID1 devices, you must have both devices on the same CPU, and a VMD on that CPU.
- Spanning drives when creating RAID devices is not recommended due to performance issues, even though it is supported.

Additional Information

- Latest SSD and operating system information:
<https://www.intel.com/content/www/us/en/support/articles/000030310/memory-and-storage/ssd-software.html>

- Additional information for the Supermicro add-on card and linked manuals:
<https://www.supermicro.com/products/accessories/addon/AOC-VROCxxxMOD.cfm>

Hardware Key

The Intel VROC hardware key is a license key that detects the Intel VROC SKU and activates the function accordingly. The key must be plugged into the Supermicro motherboard (connector JRK1). The key options are:

Intel® VROC Keys			
VROC Package	Description	Part Number	Intel MM Number
Standard	RAID 0, 1, 10 Supports 3rd party SSDs	AOC-VROCSTNMOD	951605
Premium	RAID 0, 1, 5, 10 Supports 3rd party SSDs	AOC-VROCPREMOD	951606

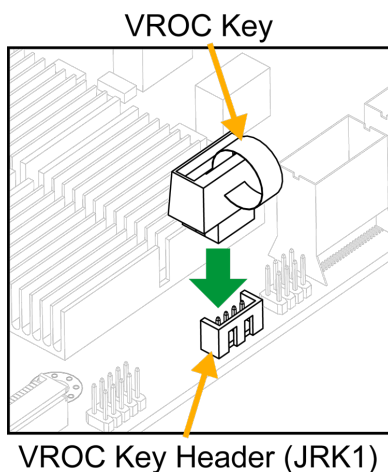

Figure 6-3. Intel VROC RAID Key and Motherboard Connector JRK1

Configuring Intel VMD

VMD must be enabled on PCIe ports which have NVMe drives attached to them in order for those drives to be added to a VROC RAID configuration. The default BIOS setting for the NVMe Mode Switch is Auto which automatically enables VMD on all installed NVMe drives.

NVMe Mode Switch:

- Auto: Enables VMD for all NVMe ports if VROC Key is installed.
- VMD: Enables VMD for all NVMe ports despite the lack of the VROC Key.
- Manual: Allows the user to select specific NVMe ports on which to enable VMD.

The NVMe Mode Switch can be viewed or selected at BIOS > Advanced > Chipset Configuration > North Bridge > IIO Configuration > Intel® VMD Technology.

Note: Without a VROC Key, there is no RAID support with the Auto switch. Only RAID 0 is supported with the VMD and Manual switches.

Configuring VMD Manually

The steps for manually configuring VMD on specific NVMe ports in UEFI BIOS are shown below. Example screenshots may differ from your server.

Important:

- If there is an existing RAID configuration, delete the RAID volume associated with the VMD controller before disabling the controller. Failure to do so may lead to unexpected behavior.
- The effects of physically changing or swapping a CPU on the VMD controller have not been thoroughly tested or documented.

1. Reboot the server and press [DEL] key to access the BIOS options.
2. Switch to Advanced > Chipset Configuration > North Bridge > IIO Configuration > Intel® VMD Technology.
3. Select VMD Mode Switch, then select Manual.

Note that Socket 0 contains CPU1; Socket 1 contains CPU2.

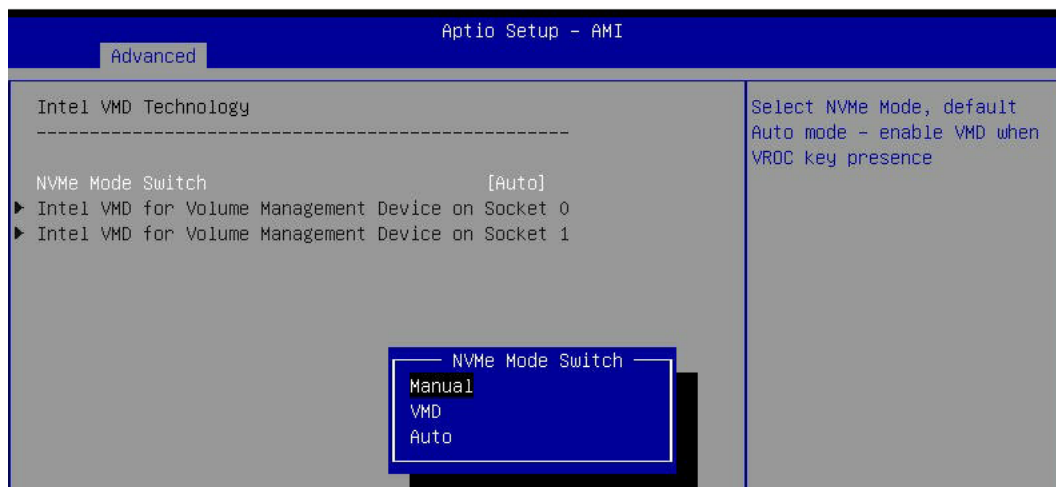

Figure 6-4. BIOS, Selecting VMD Mode

4. VMD must only be enabled on NVMe port resources. If VMD is enabled on other PCIe ports, the functionality of those ports will be impacted. See the table below.

Select “Intel VMD for Volume Management Device on” on Socket 0 (CPU1) or Socket 1 (CPU2) to enable VMD for devices under the respective CPU.

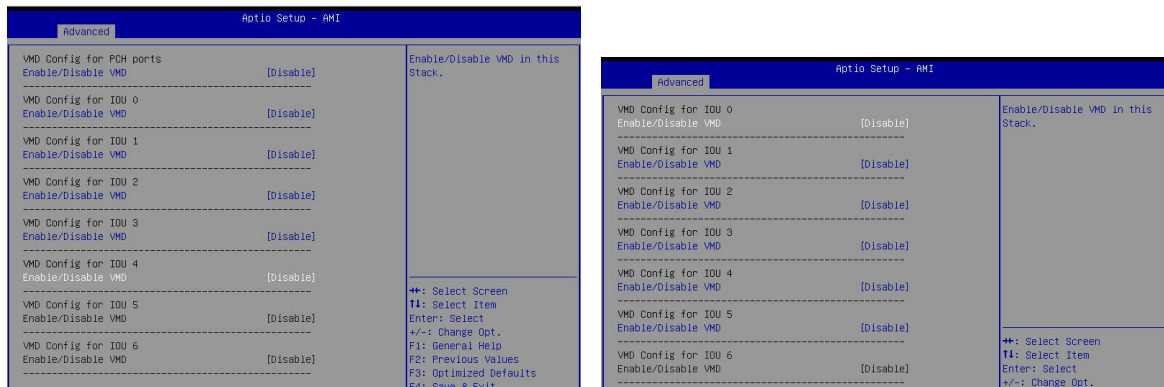

Figure 6-5. Intel VMD for Volume Management Device on Socket 0 and Socket 1

5. Choose Enable for “Enable/Disable VMD” for IOU 3 to list the available devices under IOU 3.

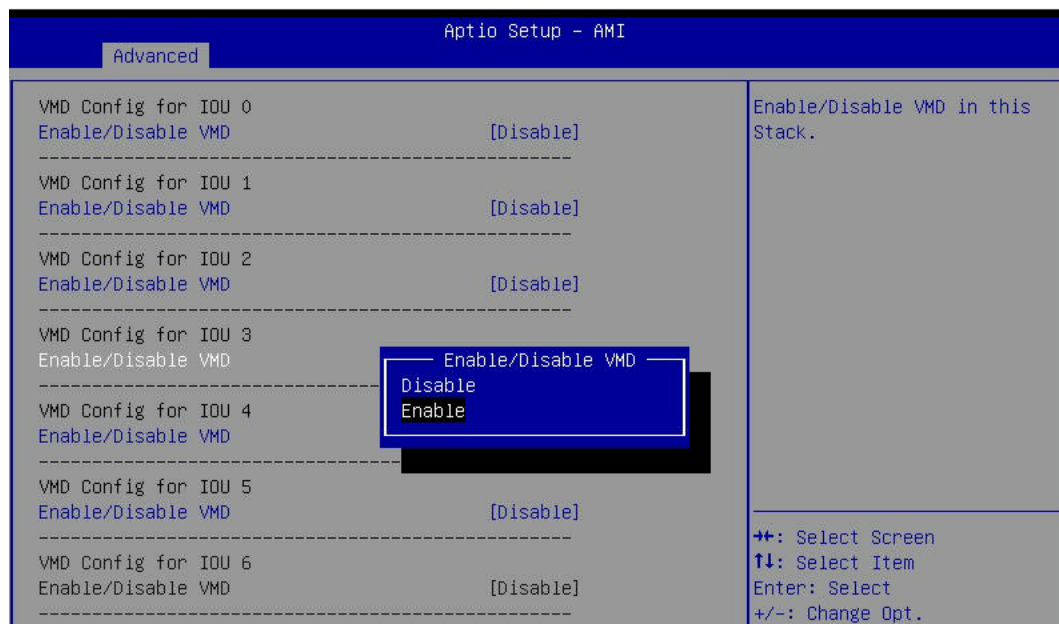

Figure 6-6. BIOS, Enabling VMD on Socket 1 (CPU2) (Example)

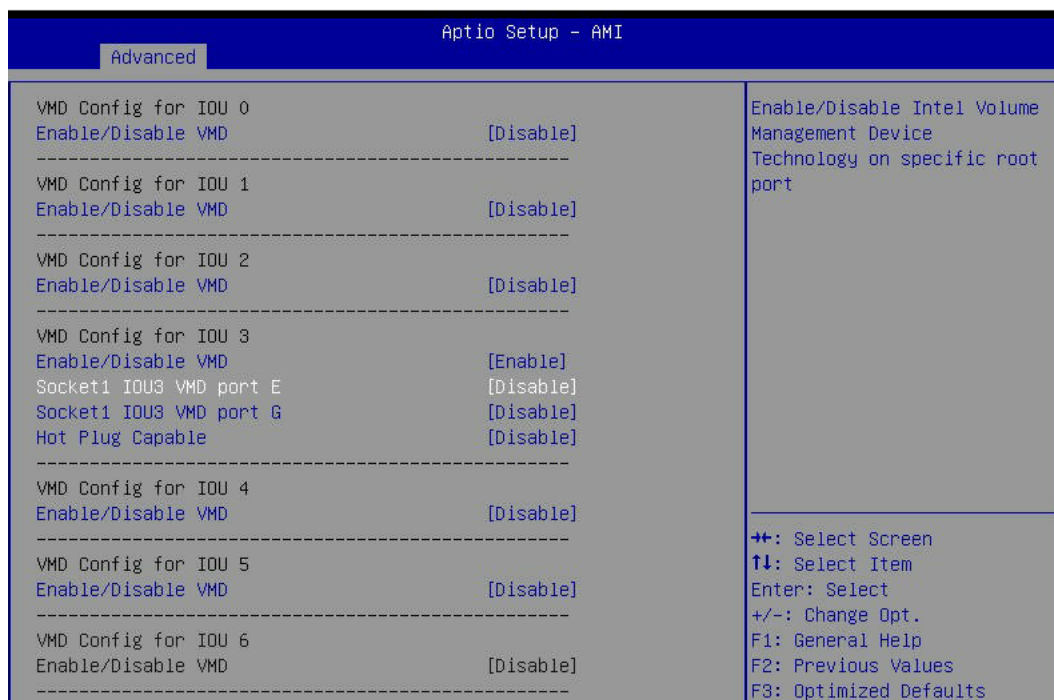

Figure 6-7. BIOS, Enabling VMD on Socket 1 (Example)

6. Enable the NVMe port resource according to table above for the NVMe drives that will be used in a RAID configuration.

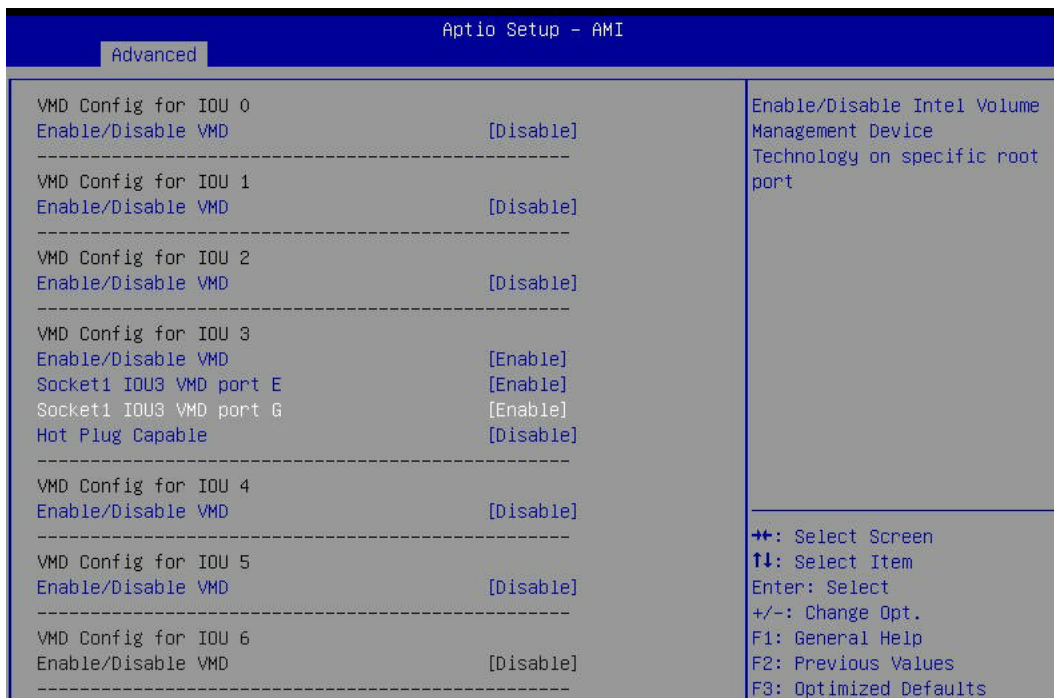

Figure 6-8. BIOS, Enabling Socket 1 (Example)

7. Choose whether to make the NVMe drives in this IOU Hot Plug Capable by selecting Enabled or Disabled.
8. Repeat steps 4 through 7 for each IOU # on each CPU to enable VMD on the desired NVMe ports.

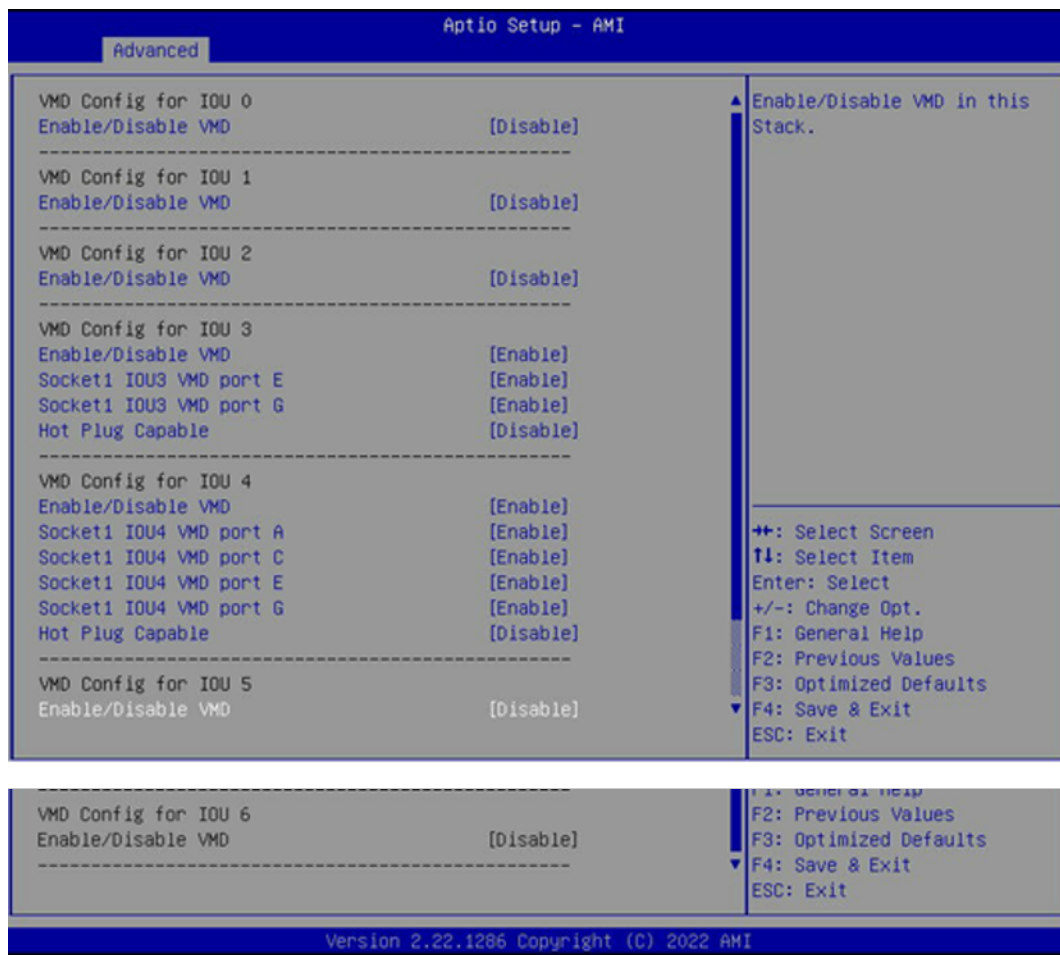

Figure 6-9. BIOS, Enabling Socket 1 Completed (Example)
 (This example shows SYS-621H-TN12R with 12 NVMe. Other systems will look different.)

9. Press [F4] to save the configuration and reboot the system.

Creating NVMe RAID Configurations

1. Open Advanced > Intel(R) Virtual RAID on CPU > All Intel VMD Controllers > Create RAID Volume.

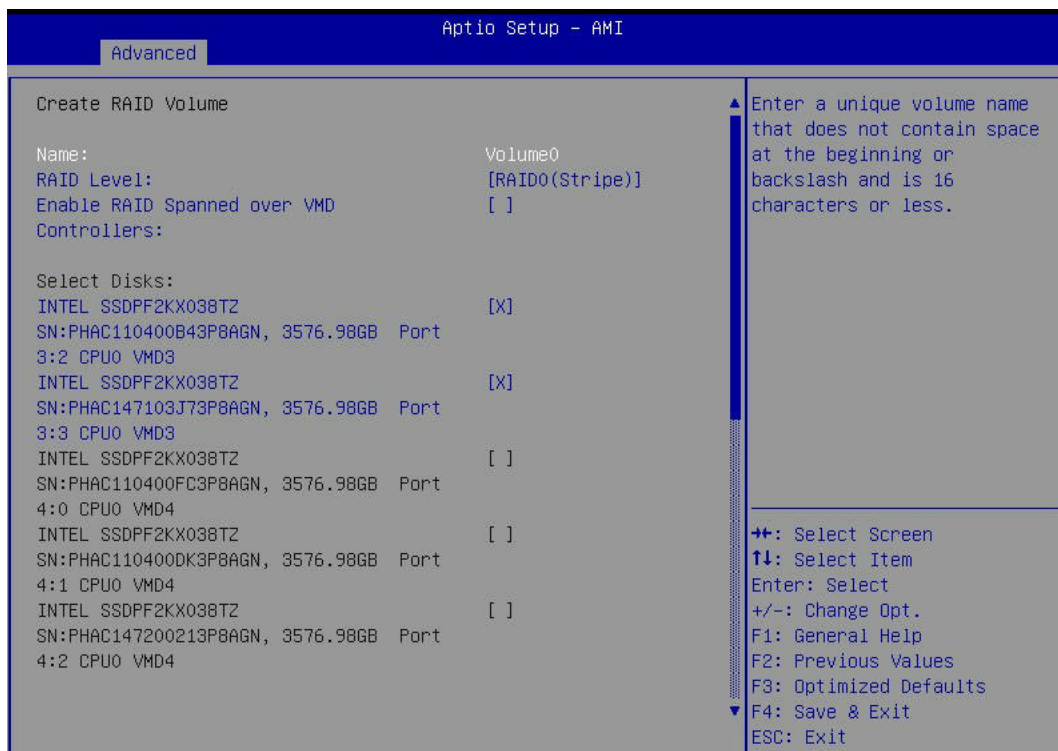

Figure 6-10. Creating Volume Without Enabling RAID Spanned over VMD Controller

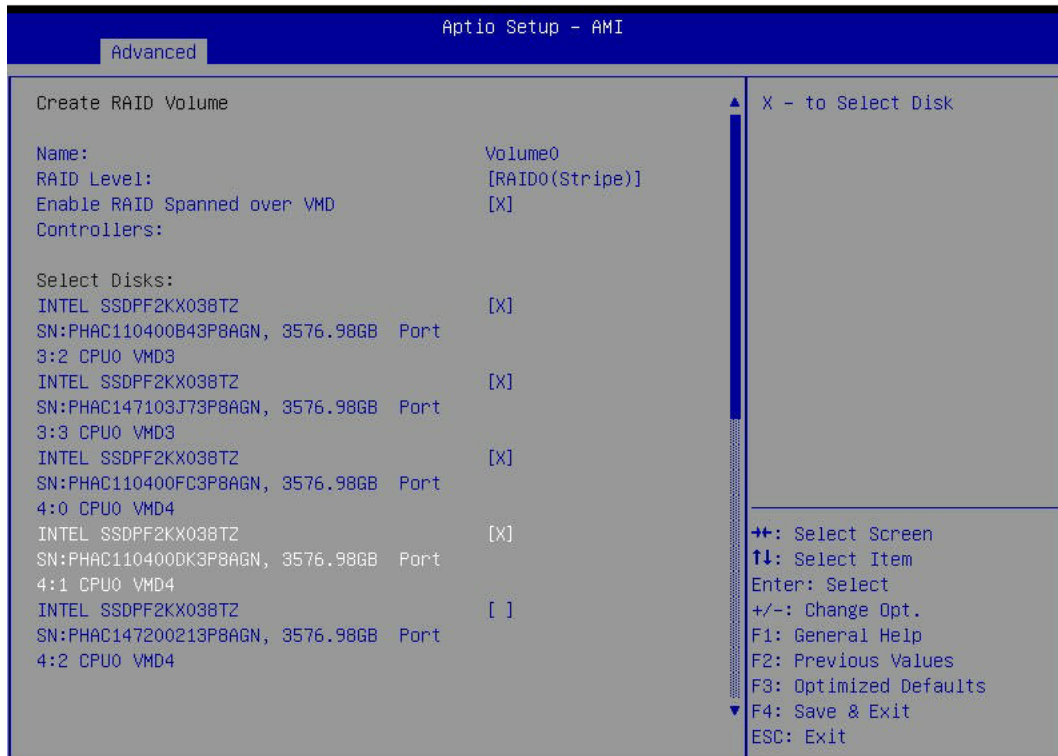

Figure 6-11. Creating Volume With Enabling RAID Spanned over VMD Controller

2. Set Name.
3. Set RAID Level.
4. If cross-controller RAID is required, select Enable RAID spanned over VMD Controller.
5. Select specific disks for RAID with an [X].
 - RAID0: Select at least two [2–24] disks
 - RAID1: Select only two disks
 - RAID5: Select at least three [3–24] disks
 - RAID10: Select only four disks
6. Select Strip Size (Default 64 KB).
7. Select Create Volume.
8. If another RAID is needed, start again at step 1.

Status Indications

An LED indicator on the drive carrier shows the RAID status of the drive.

Drive Carrier Status LED Indicator	
Status	State (red)
Normal function	Off
Locating	4 Hz blinking
Fault	Solid on
Rebuilding	1 Hz blinking
IBPI SFF 8489 Defined Status LED States	

Hot-Swap Drives

Intel VMD enables hot-plug and hot-unplug for NVMe SSDs, whether from Intel or other manufacturers. Under vSphere ESXi, several steps are necessary to avoid potential stability issues. See the information at link [1] below.

Hot-Unplug

1. Prevent devices from being re-detected during rescan:

```
esxcli storage core claiming autoclaim --enabled=false
```
2. Unmount the VMFS volumes on the device. Check link [2] below for details.

3. Detach the device. Check link [3] below for details.
4. Physically remove the device.

Hot-Plug

- Physically install the device.

ESXi will automatically discover NVMe SSDs, but a manual scan may be required in some cases.

Related Information Links

1. <https://kb.vmware.com/s/article/2151404>
2. <https://docs.vmware.com/en/VMware-vSphere/6.5/com.vmware.vsphere.storage.doc/GUID-1B56EF97-F60E-4F21-82A7-8F2A7294604D.html>
3. <https://docs.vmware.com/en/VMware-vSphere/6.5/com.vmware.vsphere.storage.doc/GUID-F2E75F67-740B-4406-9F0C-A2D99A698F2A.html>

Chapter 7:

Troubleshooting and Support

The following content contains information on common issues and how to resolve them.

7.1 Online Resources	110
7.2 Baseboard Management Controller (BMC)	111
7.3 Troubleshooting Procedures	112
Before Power On	112
No Power	112
No Video	112
System Boot Failure	112
Memory Errors	113
Losing the System's Setup Configuration	113
If the System Becomes Unstable	113
7.4 CMOS Clear	115
7.5 Motherboard Battery	116
7.6 Where to Get Replacement Components	117
7.7 Technical Support Procedures	118
Returning Merchandise for Service	118
7.8 Feedback	120

7.1 Online Resources

Website

A great deal of information is available on the Supermicro website. From the top menu of the Supermicro home page at <https://www.supermicro.com>:

- Specifications for servers and other hardware are available by clicking **Products**.
- The **Support** option offers downloads (manuals, BIOS/BMC, drivers, etc.), FAQs, RMA, warranty, and other service extensions.

Direct Links for the SYS-422GA-NRT System

- SYS-422GA-NRT system specifications page:
<https://www.supermicro.com/en/products/system/gpu/4u/sys-422ga-nrt>
- MBD-X14DBG-AP motherboard page for links to the quick reference guide, user manual, validated storage drives, and more:
<https://www.supermicro.com/en/products/motherboard/x14dbg-ap>

Direct Links for General Support and Information

- Frequently Asked Questions: <https://www.supermicro.com/FAQ/index.php>
- TPM User Guide: <https://www.supermicro.com/manuals/other/AOM-TPM-9672V.pdf>
- Product Resources page for validated memory details:
<https://www.supermicro.com/support/resources/mem.cfm>
- Product Matrices page for links to tables summarizing specs for systems, motherboards, power supplies, riser cards, add-on cards, and more:
<https://www.supermicro.com/en/support/product-matrices>
- Security Center for recent security notices:
https://www.supermicro.com/en/support/security_center
- Supermicro Phone and Addresses: <https://www.supermicro.com/en/about/contact>

7.2 Baseboard Management Controller (BMC)

The SYS-422GA-NRT server supports the Baseboard Management Controller (BMC). BMC is used to provide remote access, monitoring, and management. There are several BIOS settings that are related to BMC.

For general documentation and information on BMC, visit our website at the following page:

<https://www.supermicro.com/en/solutions/management-software/bmc-resources>

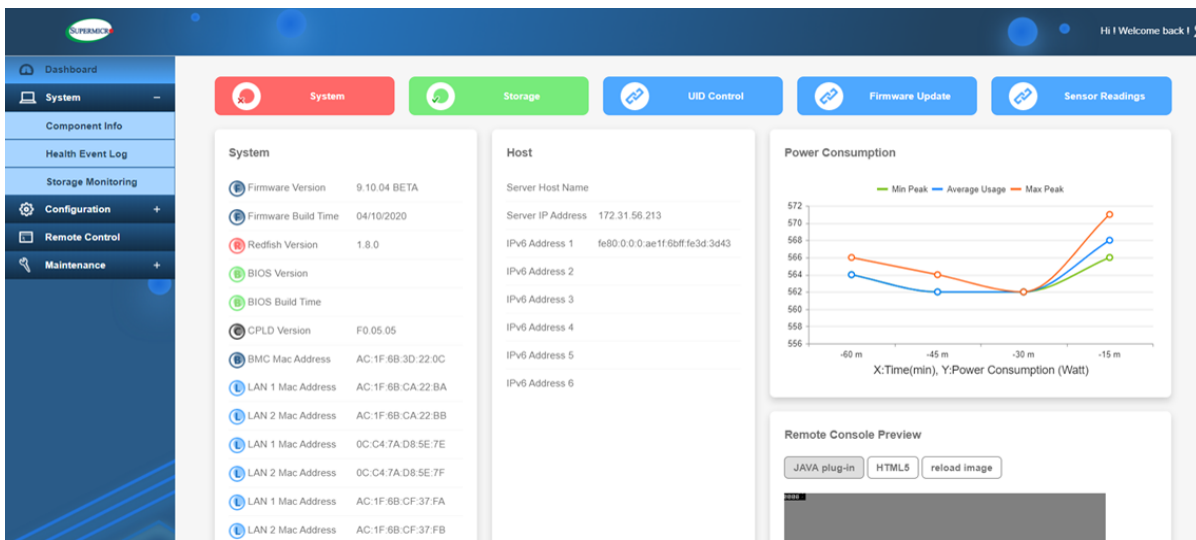

Figure 7-1. BMC Dashboard

7.3 Troubleshooting Procedures

Use the following procedures to troubleshoot your system. If you have followed all of the procedures below and still need assistance, refer to the ["Technical Support Procedures" on page 118](#) section in this chapter. Always disconnect the AC power cord before adding, changing or installing any non hot-swappable hardware components. If the below steps do not fix the setup configuration problem, contact your vendor for repairs.

Before Power On

1. Make sure that there are no short circuits between the motherboard and chassis.
2. Disconnect all ribbon/wire cables from the motherboard, including those for the keyboard and mouse.
3. Remove all add-on cards.
4. Install the processor (making sure it is fully seated) and connect the front panel connectors to the motherboard.

No Power

1. Make sure that there are no short circuits between the motherboard and the chassis.
2. The battery on your motherboard may be old. Check to verify that it still supplies approximately 3 VDC. If it does not, replace it with a new one.

No Video

1. If the power is on, but you do not have video, remove all add-on cards and cables.
2. Remove all memory modules and turn on the system (if the alarm is on, check the specs of memory modules, reset the memory, or try a different one).

System Boot Failure

If the system does not display Power-On-Self-Test (POST) or does not respond after the power is turned on, do the following:

1. Remove all components from the motherboard, especially the DIMMs. Power on the system and check if the power-on LED and the BMC Heartbeat LED are on, and system fans are spinning.

2. Turn on the system with only one DIMM installed. If the system boots, check for bad DIMMs or slots by following the Memory Errors Troubleshooting procedure in this chapter.

Memory Errors

When suspecting faulty memory is causing the system issue, check the following:

1. Make sure that the memory modules are compatible with the system and are properly installed. See "[Maintenance and Component Installation](#)" on [page 36](#) for installation instructions. (For memory compatibility, refer to the "Tested Memory List" link on the motherboard's product page to see a list of supported memory.)
2. Check if different speeds of DIMMs have been installed. It is strongly recommended that you use the same RAM type and speed for all DIMMs in the system.
3. Make sure that you are using the correct type of DIMMs recommended by the manufacturer.
4. Check for bad DIMMs or slots by swapping a single module among all memory slots and check the results.

Losing the System's Setup Configuration

1. Make sure that you are using a high-quality power supply. A poor-quality power supply may cause the system to lose the CMOS setup information. Refer to "[Introduction](#)" on [page 13](#) for details on recommended power supplies.
2. The battery on your motherboard may be old. Check to verify that it still supplies approximately 3 VDC. If it does not, replace it with a new one.

If the System Becomes Unstable

If the system becomes unstable during or after OS installation, check the following:

1. Processor/BIOS support: Make sure that your processor is supported and that you have the latest BIOS installed in your system.
2. Memory support: Make sure that the memory modules are supported. Refer to the product page on our website at <https://www.supermicro.com>. Test the modules using memtest86 or a similar utility.

Note: Click on the "Tested Memory List" link on the motherboard's product page to see a list of supported memory.

3. Storage Drive support: Make sure that all storage drives work properly. Replace the failed storage drives with good ones.
4. System cooling: Check the system cooling to make sure that all heatsink fans and processor/system fans, etc., work properly. Check the hardware monitoring settings in the BMC to make sure that the processor and system temperatures are within the normal range. Also, check the front panel Overheat LED and make sure that it is not on.
5. Adequate power supply: Make sure that the power supply provides adequate power to the system. Make sure that all power connectors are connected. Refer to our website for more information on the minimum power requirements.
6. Proper software support: Make sure that the correct drivers are used.

If the system becomes unstable before or during OS installation, check the following:

1. Source of installation: Make sure that the devices used for installation are working properly, including boot devices such as a CD/Media drive.
2. Cable connection: Check to make sure that all cables are connected and working properly.
3. Use the minimum configuration for troubleshooting: Remove all unnecessary components (starting with add-on cards first), and use the minimum configuration (but with the processor and a memory module installed) to identify the trouble areas. Refer to the steps listed above in this section for proper troubleshooting procedures.
4. Identify bad components by isolating them: If necessary, remove a component in question from the chassis, and test it in isolation to make sure that it works properly. Replace a bad component with a good one.
5. Check and change one component at a time instead of changing several items at the same time. This will help isolate and identify the problem.
6. To find out if a component is good, swap this component with a new one to see if the system will work properly. If so, then the old component is bad. You can also install the component in question in another system. If the new system works, the component is good and the old system has problems.

7.4 CMOS Clear

JBT1 on the MBD-X14DBG-AP motherboard is used to clear CMOS, which will also clear any passwords. For information on clearing CMOS, refer to ["CMOS Clear" on page 83](#) earlier in this manual.

7.5 Motherboard Battery

For information on removing, disposing of, and replacing the motherboard battery of your system, refer to ["Motherboard Battery Removal and Installation" on page 58](#).

7.6 Where to Get Replacement Components

If you need replacement parts for your SYS-422GA-NRT server, to ensure the highest level of professional service and technical support, purchase exclusively from our Supermicro Authorized Distributors/System Integrators/Resellers. A list can be found on the Supermicro website:

<https://www.supermicro.com>

Under the "Buy" menu, click the "Where to Buy" link.

7.7 Technical Support Procedures

Before contacting Technical Support, take the following steps. Also, note that as a motherboard manufacturer, Supermicro also sells motherboards through its channels, so it is best to first check with your distributor or reseller for troubleshooting services. They should know of any possible problems with the specific system configuration that was sold to you.

1. Refer to "Troubleshooting Procedures" on page 112 or see the FAQs on our website (<https://www.supermicro.com/FAQ/index.php>) before contacting Technical Support.
2. BIOS upgrades can be downloaded from our website (https://www.supermicro.com/support/resources/bios_ipmi.php).
3. If you still cannot resolve the problem, include the following information when contacting Supermicro for technical support:
 - Motherboard model and PCB revision number
 - BIOS release date/version (This can be seen on the initial display when your system first boots up.)
 - System configuration
4. An example of a Technical Support form is on our website at <https://webpr3.supermicro.com/SupportPortal>.
5. Distributors: For immediate assistance, have your account number ready when placing a call to our Technical Support department. For Supermicro contact information, refer to "Contacting Supermicro" on page 12.

Returning Merchandise for Service

A receipt or copy of your invoice marked with the date of purchase is required before any warranty service will be rendered. You can obtain service by calling your vendor for a Returned Merchandise Authorization (RMA) number. When returning the server to the manufacturer, the RMA number should be prominently displayed on the outside of the shipping carton, and the shipping package is mailed prepaid or hand-carried. Shipping and handling charges will be applied for all orders that must be mailed when service is complete.

For faster service, RMA authorizations can be requested online at the following page:

<https://www.supermicro.com/RmaForm>

Whenever possible, repack the server in the original Supermicro carton, using the original packaging material. If these are no longer available, be sure to pack the server securely, using packaging material to surround the server so that it does not shift within the carton and become damaged during shipping.

This warranty only covers normal consumer use and does not cover damages incurred in shipping or from failure due to the alternation, misuse, abuse or improper maintenance of products.

During the warranty period, contact your distributor first for any product problems.

7.8 Feedback

Supermicro values your feedback as we strive to improve our customer experience in all facets of our business. Email us at Techwriterteam@supermicro.com to provide feedback on our manuals.

Chapter 8:

UEFI BIOS

The following content contains information on BIOS configuration with the SYS-422GA-NRT server.

8.1 Introduction	122
8.2 Main Setup	124
8.3 Advanced Setup Configurations	126
8.4 Event Logs	171
8.5 BMC	173
8.6 Security	177
8.7 Boot	184
8.8 Save & Exit	186

8.1 Introduction

This chapter describes the AMIBIOS™ Setup utility for the motherboard. The BIOS is stored on a chip and can be easily upgraded using the UEFI script (flash.nsh), the BMC WebUI, or the SuperServer Automation Assistant (SAA) utility.

Note: Due to periodic changes to the BIOS, some settings may have been added or deleted and might not yet be recorded in this manual. Refer to the Manual Download area of our website for any changes to BIOS that may not be reflected in this manual.

Updating BIOS

It is recommended that you do not upgrade your BIOS if you are not experiencing any problems with your system. Updated BIOS files are located on our website at the following page:

https://www.supermicro.com/support/resources/bios_ipmi.php

Check our BIOS warning message and the information on how to update your BIOS on our website. Select your motherboard model and download the BIOS file to your computer. Also, check the current BIOS revision to make sure that it is newer than your BIOS before downloading.

Important: Do not shut down or reset the system while updating the BIOS to prevent possible system boot failure! Read the motherboard README file carefully before you perform the BIOS update.

To update the BIOS under the UEFI Shell, unzip the BIOS file onto a bootable USB device and then boot into the built-in UEFI Shell. For motherboards with BMC support, type "flash.nsh <BIOS filename><BMC Username><BMC Password>" to start the BIOS update. The flash.nsh script will invoke the SAA (EFI) tool automatically to perform the BIOS update, beginning with uploading the BIOS image to BMC. After uploading the BIOS image, the system will reboot to continue the process. The BMC will take over and continue the BIOS update in the background. The process will take 3–5 minutes. Refer to the README file for more information.

Starting the Setup Utility

To enter the BIOS Setup utility, press the <Delete> key while the system is booting-up. In most cases, the <Delete> key is used to invoke the BIOS Setup screen. There are a few cases when other hot keys are used, such as <F1>, <F2>, etc. Each main BIOS menu option is described in this manual.

The Main BIOS screen has two main frames. The left frame displays all the options that can be configured. "Grayed-out" options cannot be configured. The right frame displays the key legend. Above the key legend is an area reserved for a text message. When a BIOS submenu or item is selected in the left frame, it is highlighted in white. Often a text message will accompany it. (Note that BIOS has default text messages built in. We retain the option to include, omit, or change any of these text messages.) Settings printed in **Bold** are the default values.

A "▶" indicates a submenu. Highlighting such an item and pressing the <Enter> key open the list of settings within that submenu.

The BIOS Setup utility uses a key-based navigation system called hot keys. Most of these hot keys (<F1>, <F2>, <F3>, <F4>, <F5>, <F6>, <Enter>, <ESC>, the arrow keys, etc.) can be used at any time during the setup navigation process.

8.2 Main Setup

The Main setup screen appears when the AMI BIOS Setup utility is first entered. To return to the Main setup screen, select the Main tab at the top of the screen. The Main BIOS setup screen is shown below.

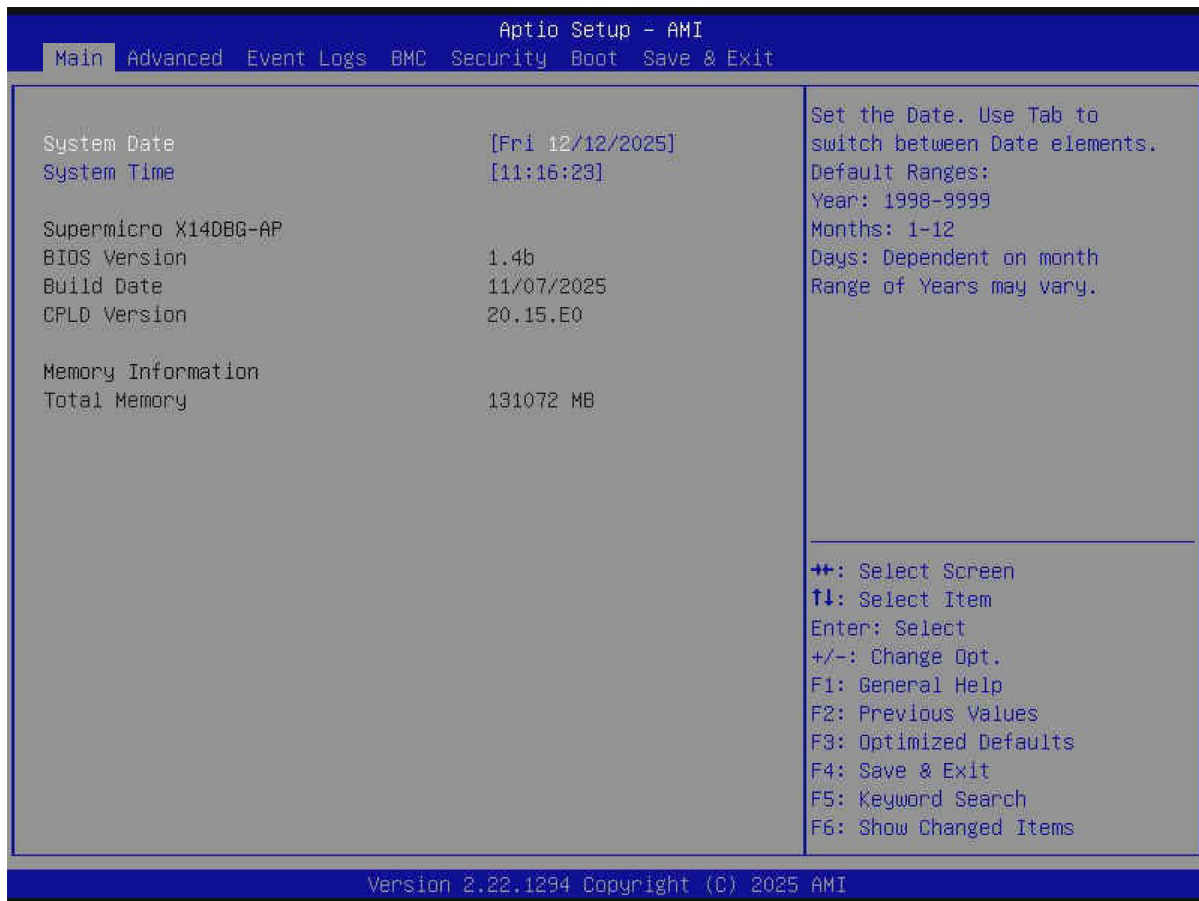

Figure 8-1. Main Setup Page

System Date/System Time

Use the two features to change the system date and time. Highlight **System Date** or **System Time** using the arrow keys. Enter new values using the keyboard. Press the <Tab> key or the arrow keys to move between fields. The date must be entered in MM/DD/YYYY format. The time is entered in HH:MM:SS format.

Note: The time is in the 24-hour format. For example, 5:30 P.M. appears as 17:30:00.

Supermicro MBD-X14DBG-AP

BIOS Version

This feature displays the version of the BIOS ROM used in the system.

Build Date

This feature displays the date when the version of the BIOS ROM used in the system was built.

CPLD Version

This feature displays the version of the Complex-Programmable Logical Device (CPLD) used in the system.

Memory Information**Total Memory**

This feature displays the total size of memory available in the system.

8.3 Advanced Setup Configurations

Use the arrow keys to select the Advanced submenu and press <Enter> to access the submenu items.

Important: Use caution when changing the Advanced settings. An incorrect value, an improper DRAM frequency, or a wrong BIOS timing setting may cause the system to malfunction. When this occurs, revert the settings to the default manufacturing settings.

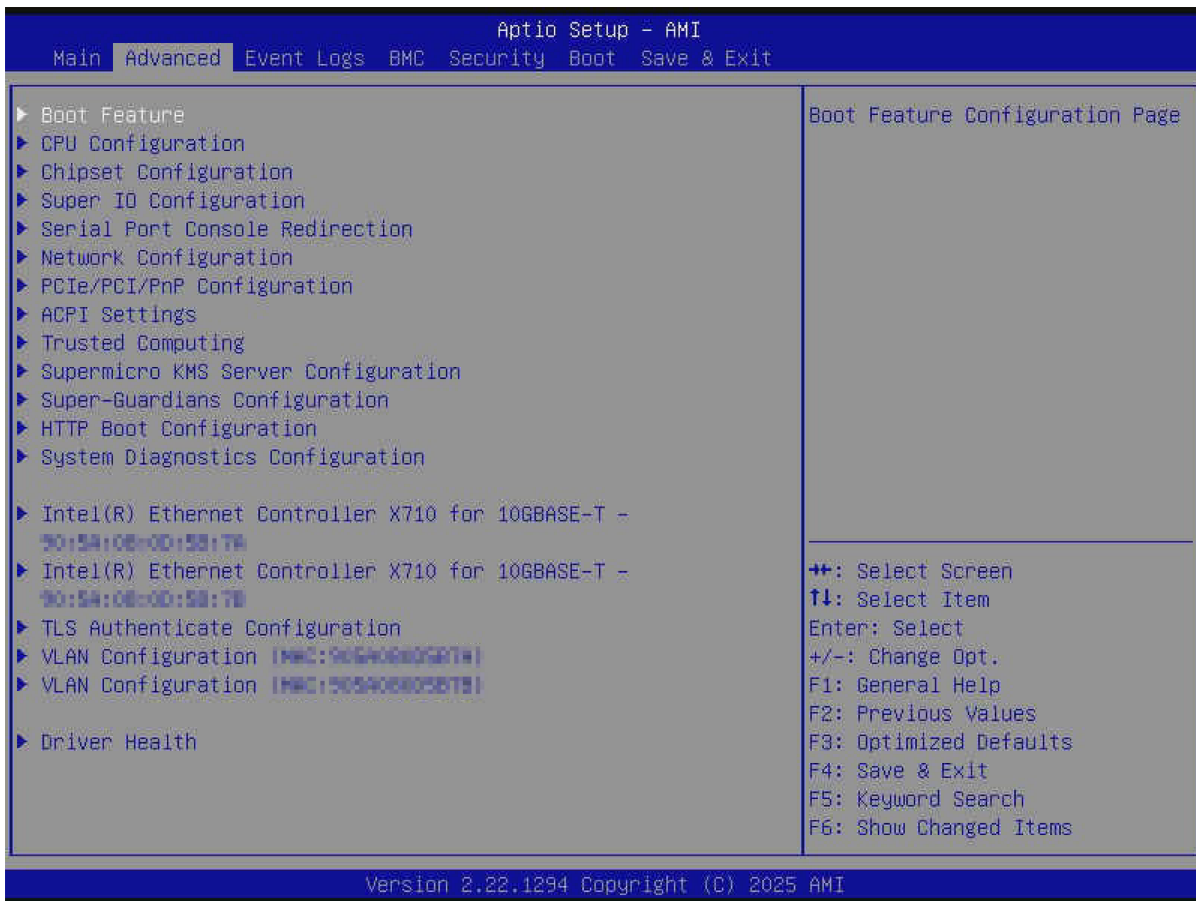

Figure 8-2. Advanced Setup Page

Boot Feature Menu

► Boot Feature

Quiet Boot

Use this feature to select the screen between displaying the Power On Self Test (POST) messages or the OEM logo upon bootup. Select Disabled to display the POST messages. Select Enabled to display the OEM logo instead of the normal POST messages. The options

are Disabled and **Enabled**.

Note: BIOS POST messages are always displayed regardless of the setting of this feature.

Bootup NumLock State

Use this feature to set the power on state for the <Num Lock> key. The options are **On** and Off.

Wait For "F1" If Error

Select Enabled to force the system to wait until the <F1> key is pressed if an error occurs. The options are **Disabled** and Enabled.

Re-try Boot

If this feature is set to Enabled, the system BIOS will automatically reboot the system from an Extensible Firmware Interface (EFI) boot device after an initial boot failure. The options are **Disabled** and Enabled.

Runtime Variable Lock

Enable this feature to manage access to non-volatile memory (NVRAM) variables and use specific runtime services with write protection. The options are **Disabled** and Enabled.

Power Configuration

Watch Dog Function

Select Enabled to allow the Watchdog timer to reboot the system when it is inactive for more than five minutes. The options are **Disabled** and Enabled.

Watch Dog Action (Available when "Watch Dog Function" is set to Enabled)

Use this feature to configure the Watchdog timeout setting. The options are **Reset** and NMI.

Restore on AC Power Loss

Use this feature to set the power state after a power outage. Select Stay Off for the system power to remain off after a power loss. Select Power On for the system power to be turned on after a power loss. Select Last State to allow the system to resume its last power state before a power loss. The options are Stay Off, Power On, and **Last State**.

Power Button Function

This feature controls how the system shuts down when the power button is pressed. Select 4 Seconds Override to power off the system after pressing and holding the power button for four seconds or longer. Select Instant Off to instantly power off the system as soon as you press the power button. The options are **Instant Off** and 4 Seconds Override.

CPU Configuration Menu

► CPU Configuration

Important: Setting the wrong values for the features included in the following sections may cause the system to malfunction.

The following processor information is displayed:

- Processor BSP Revision
- Processor Socket
- Processor ID
- Processor Frequency
- Processor Max Ratio
- Processor Min Ratio
- Microcode Revision
- L1 Cache RAM (Per Core)
- L2 Cache RAM (Per Core)
- L3 Cache RAM (Per Package)
- Processor 0 Version

Hyper-Threading [ALL]

Select Enabled to use Intel Hyper-Threading Technology to enhance CPU performance. The options are Disabled and **Enabled**. This feature is CPU-dependent.

Hardware Prefetcher

If this feature is set to Enabled, the hardware prefetcher will prefetch data from the main system memory to Level 2 cache to help expedite the data transaction to enhance memory performance. The options are **Enabled** and Disabled.

Note: This feature is NOT available when "Workload Profile" is set to HPC, I/O, or Virtualization.

Adjacent Cache Prefetch

Select Enabled for the CPU to prefetch both cache lines for 128 bytes as comprised. Select Disabled for the CPU to prefetch both cache lines for 64 bytes. The options are **Enabled** and Disabled.

Note: This feature is NOT available when "Workload Profile" is set to HPC, I/O, or Virtualization.

DCU Streamer Prefetcher

If this feature is set to Enabled, the Data Cache Unit (DCU) streamer prefetcher will prefetch data streams from the cache memory to the DCU to speed up data accessing and processing to enhance CPU performance. The options are Enabled, Disabled, and **Auto**.

Note: This feature is NOT available when "Workload Profile" is set to HPC, I/O, or Virtualization.

DCU IP Prefetcher

This feature allows the system to use the sequential load history, which is based on the instruction pointer of previous loads, to determine whether the system will prefetch additional lines. The options are **Enabled** and Disabled.

Note: This feature is NOT available when "Workload Profile" is set to HPC, I/O, or Virtualization.

LLC Prefetch

If this feature is set to Enabled, LLC (hardware cache) prefetching on all threads will be supported. The options are **Disabled** and Enabled. This feature is CPU-dependent.

Note: This feature is NOT available when "Workload Profile" is set to HPC, I/O, or Virtualization.

Homeless Prefetch

Select Enabled for Homeless Prefetch support on all threads, which is an Effective Prefetch Strategy (EPS) used to enhance memory performance by reducing communication overhead, network latency, and the wait time needed for barrier synchronization in memory prefetching commonly associated with the home-based software Distributed Shared Memory (DSM) system. The options are Disabled, Enabled, and **Auto**. Please note that the option of Auto is program-specific. This feature is CPU-dependent.

AMP Prefetch

Select Enabled to use a machine learning algorithm to predict the best L2 prefetcher configuration for the currently running workload. This feature can improve the performance of various general-purpose workloads. The options are Disabled and **Enabled**. This feature is CPU-dependent.

APIC Physical Mode

Use this feature to enable the APIC physical destination mode. The options are **Disabled** and Enabled. (APIC is the abbreviation for Extended Advanced Programmable Interrupt Controller.)

IIO LLC Ways Mask (Hex)

This feature sets a specific temporary register bit mask that is used to control or monitor Last Level Cache (LLC) cache configuration and allocation. The default setting is **0**. (IIO is the abbreviation for Intel I/O.)

TXT Support

Select Enabled to enable Intel Trusted Execution Technology (TXT) support to enhance system integrity and data security. The options are **Disabled** and Enabled. This feature is CPU-dependent.

Note: If this feature is set to Enabled, be sure to disable Device Function On-Hide (EV DFX) support when it is present in the BIOS for the system to work properly.

Intel Virtualization Technology

Select Enabled to enable the Intel Vanderpool Technology for Virtualization platform support, which allows multiple operating systems to run simultaneously on the same computer to maximize system resources for performance enhancement. The options are Disabled and **Enabled**. Changes take effect after you save settings and reboot the system.

Notes:

- This feature is NOT available when "TXT Support" is set to Enabled.
- This feature is NOT available when "Workload Profile" is set to Virtualization.

Enable SMX

Select Enabled to support Safer Mode Extensions (SMX), which provides a programming interface for system software to establish a controlled environment to support the trusted platform configured by the end user and to verify a virtual machine monitor before it is allowed to run. The options are **Disabled** and Enabled.

Note: This feature is available when "TXT Support" is set to Disabled.

PPIN Control

Select Unlock/Enabled to use the Protected Processor Inventory Number (PPIN) in the system. The PPIN is a unique number set for tracking a given Intel Xeon server processor. The options are Lock/Disabled and **Unlock/Enabled**.

AES-NI

Select Enabled to use the Intel Advanced Encryption Standard (AES) New Instructions (NI) to ensure data security. The options are Disabled and **Enabled**.

Advanced Power Management Configuration Menu

► **Advanced Power Management Configuration**

Latency Optimized Mode

Select Enabled to set the power mode to the latency optimized mode to improve the latency. The options are **Disabled** and Enabled. This feature is motherboard-dependent.

Note: This feature is NOT available when "Workload Profile" is set to HPC or Virtualization.

Workload Profile

Use this feature to select a preconfigured workload profile, which is used to tune the resources in your system. The options are **Disabled**, HPC, I/O, Virtualization, Telco NFVI, Telco NFVI-FP, and Telco FlexRAN. Changes take effect after you save settings and reboot the system. (NFVI is the abbreviation for Network Functions Virtualization Infrastructure. NFVI-FP is the abbreviation for Network Functions Virtualization Infrastructure Forwarding Platform. RAN is the abbreviation for Radio Access Network.)

Note: Select HPC to optimize power performance of High Performance Computing (HPC) workloads for your system running in the HPC environment. Select I/O for I/O intensive workloads to optimize power performance of high volume of data transfers to and from system memory and storage devices or any program. Select Virtualization to optimize power performance of the workload for your system running in the virtualization environment. Select Telco NFVI to optimize power performance of NFVI workloads for your system. Select Telco NFVI-FP to optimize power performance of NFVI-FP workloads for your system. Select Telco FlexRAN to achieve optimal performance with low power consumption for Intel FlexRANTM based implementations.

Power Performance Tuning

This feature allows either operating system (OS) or BIOS to control the EPB. The options are **OS Controls EPB** and BIOS Controls EPB. (PECI is the abbreviation for Platform Environment Control Interface. EPB is the abbreviation for Intel Performance and Energy Bias Hint.)

Note: This feature is available when "Workload Profile" is set to Disabled.

ENERGY_PERF_BIAS_CFG Mode (ENERGY PERFORMANCE BIAS CONFIGURATION Mode)

Use this feature to configure the proper operation setting for your machine by achieving the desired system performance level and energy saving (efficiency) level at the same time. Select Maximum Performance to maximize system performance to its highest potential; however, this may consume maximal amount of power as energy is needed to fuel processor operation. Select Performance to enhance system performance; however, this may consume more power as energy is needed to fuel the processors for operation. The options are Extreme Performance, Maximum Performance, Performance, **Balanced Performance**, Balanced Power, Power, and Max Power Efficient. Note that the options of Extreme Performance and Max Power Efficient are motherboard-dependent.

Notes:

- This feature is available when "Power Performance Tuning" is set to BIOS Controls EPB.
- This feature is available when "Workload Profile" is set to Disabled.

CPU P State Control Menu

► CPU P State Control

Note: This submenu is available when "Power Performance Tuning" is set to BIOS Controls EPB.

AVX P1

Use this feature to set the appropriate TDP level for the system. The Intel Advanced Vector Extensions (Intel AVX) P1 feature allows you to set the base P1 ratio for Streaming SIMD Extensions (SSE) and AVX workloads. Each P1 ratio has the corresponding AVX Impressed Current Cathodic Protection (ICCP) pre-grant license level, which refers to the selection between different AVX ICCP transition levels. The options are **Nominal**, Level 1, and Level 2. This feature is CPU-dependent.

Notes:

- This feature is available when "SpeedStep (P-States)" is set to Enabled.
- This feature is NOT available when "Workload Profile" is set to Telco FlexRAN.

Intel SST-PP

Use this feature to choose from two additional Base-Frequency conditions maximum for CPU P State Control. The options are **Auto**, Level 0, Level 1, Level 2, Level 3, and Level 4. The options regarding SST-PP levels are CPU-dependent. (SST-PP is the abbreviation for Speed Select Technology-Performance Profile.)

Notes:

- This feature is available when "SpeedStep (P-States)" is set to Enabled and when the number of SST-PP levels supported by your CPU is no less than two.
- This feature is NOT available when "Workload Profile" is set to Telco NFVI, Telco NFVI-FP, or Telco FlexRAN.

Dynamic SST-PP

Use this feature to disable or enable the dynamic SST-PP. The options are **Disabled** and Enabled.

Notes:

- This feature is available when "SpeedStep (P-States)" is set to Enabled and when your CPU supports the Intel Speed Select function.
- This feature is available when "AVX P1" is set to Nominal.
- This feature is NOT available when "Hardware P-States" is set to Disabled or Out of Band Mode.
- This feature is NOT available when "Workload Profile" is set to HPC or Virtualization.

When "SpeedStep (P-States)" is set to Enabled, the information about SST-PP levels supported by your CPU is displayed.

- SST-PP Level
- Capable
- Core Count
- P1 Ratio
- Package TDP (W)
- DTS_Max

SpeedStep (P-States)

Enhanced Intel SpeedStep Technology (EIST) allows the system to automatically adjust processor voltage and core frequency in an effort to reduce power consumption and heat dissipation. Refer to Intel's website for detailed information. The options are Disabled and **Enabled**.

Note: This feature is available when "Workload Profile" is set to Disabled.

EIST PSD Function

This feature reduces the latency that occurs when one P-state changes to another, thus allowing the transitions to occur more frequently. This will allow for more demand-based P-state switching to occur based on the real-time energy needs of applications so that the power-to-performance balance can be optimized for energy efficiency. The options are **HW_ALL** and **SW_ALL**.

Notes:

- This feature is available when "SpeedStep (P-States)" is set to Enabled.
- This feature is NOT available when "Workload Profile" is set to Telco NFVI, Telco NFVI-FP, or Telco FlexRAN.

Turbo Mode

Select Enabled to allow the CPU to operate at the manufacturer-defined turbo speed by increasing CPU clock frequency. This feature is available when it is supported by the processors used in the system. The options are Disabled and **Enabled**.

Notes:

- This feature is available when "SpeedStep (P-States)" is set to Enabled.
- This feature is available when "Workload Profile" is set to Disabled.

Hardware PM State Control Menu

▶ **Hardware PM State Control**

Notes:

- This submenu is available when “Power Performance Tuning” is set to BIOS Controls EPB.
- This submenu is NOT available when “Workload Profile” is set to HPC or Virtualization.

Hardware P-States

If this feature is set to Disabled, system hardware will choose a P-state setting for the system based on an OS request. If this feature is set to Native Mode, system hardware will choose a P-state setting based on the OS guidance. If this feature is set to Native Mode with No Legacy Support, system hardware will choose a P-state setting independently without the OS guidance. The options are Disabled, **Native Mode**, Out of Band Mode, and Native Mode with No Legacy Support.

CPU C State Control Menu

▶ **CPU C State Control**

Note: This submenu is available when “Power Performance Tuning” is set to BIOS Controls EPB.

Monitor MWAIT

Select Enabled to support MONITOR and MWAIT, which are two instructions in Streaming SIMD Extension 3 (SSE3) to improve synchronization between multiple threads for CPU performance enhancement. The options are Disabled and **Enabled**.

Note: This feature is NOT available when "Workload Profile" is set to Telco NFVI, Telco NFVI-FP, or Telco FlexRAN.

C1 to C1e Promotion

If this feature is set to Enabled, CPU will run at its minimum frequency for lower power consumption in the C1 state. The options are Disabled and **Enabled**. This feature is CPU-dependent.

Note: This feature is available when "Workload Profile" is set to Disabled.

ACPI C1 Enumeration

Use this feature to select the ACPI C1 state or the ACPI C1e state. The options are C1 and **C1e**. This feature is CPU-dependent. (ACPI is the abbreviation for Advanced Configuration and Power Interface.)

Note: This feature is available when "Workload Profile" is set to Disabled.

ACPI C6x Enumeration

Use this feature to configure C6 state or C6 P-state as ACPI C2 or ACPI C3 state. The options are Disabled, C6 as ACPI C2, C6 as ACPI C3, C6-P as ACPI C2, C6-P as ACPI C3, and **Auto**.

Note: This feature is available when "Workload Profile" is set to Disabled.

Package C State Control Menu

► Package C State Control

Note: This submenu is available when "Power Performance Tuning" is set to BIOS Controls EPB.

Package C State

Use this feature to optimize and reduce CPU package power consumption in the idle mode. Please note that the changes you've made in this setting will affect all CPU cores or the circuits of the entire system. The options are C0/C1 state, C2 state, C6 (non Retention) state, No Limit, and **Auto**.

Note: This feature is NOT available when "Workload Profile" is set to I/O.

LTR IIO Input

Use this feature to set the MSR 1FCh Bit[29]. The options are Take IIO LTR input and **Ignore IIO LTR input**.

CPU1 Core Disable Bitmap Menu

► CPU1 Core Disable Bitmap

Available Bitmap[0]:

This feature displays the available Bitmap[0]. This feature is CPU-dependent.

Available Bitmap[1]:

This feature displays the available Bitmap[1]. This feature is CPU-dependent.

CPU Core Count:

This feature displays the number of CPU cores that can be enabled.

CPU1 Cores Enable

Use this feature to set the number of CPU cores to be enabled. Enter 0 to enable all CPU cores. Note that it is required to enable at least one core per CPU. The default setting is **0**.

Chipset Configuration Menu

► Chipset Configuration

Important: Setting the wrong values in this section may cause the system to malfunction.

Uncore Configuration Menu

► Uncore Configuration

The following information is displayed.

- Number of CPU
- Current UPI Link Speed
- Current UPI Link Frequency
- Global MMIO Low Base / Limit
- Global MMIO High Base / Limit
- PCIe Configuration Base / Size

Degrade Precedence

Use this feature to select the degrading precedence option for Ultra Path Interconnect (UPI) connections. Select Topology Precedence to degrade UPI features if system options are in conflict. Select Feature Precedence to degrade UPI topology if system options are in conflict. The options are **Topology Precedence** and Feature Precedence.

Link L0p Enable

Select Enabled for the system BIOS to enable Link L0p support, which allows the CPU to reduce the UPI links from full width to half width in the event when the CPU's workload is low in an attempt to save power. This feature is available for the system that uses Intel processors with UPI technology support. The options are **Disabled**, Enabled, and Auto.

Note: You can change the performance settings for non-standard applications by using this parameter. It is recommended that the default settings be used for standard applications.

Link L1 Enable

Select Enabled for the BIOS to activate Link L1 support, which will power down the UPI links to save power when the system is idle. This feature is available for the system that uses Intel processors with UPI technology support. The options are **Disabled**, Enabled, and Auto.

Note: Link L1 is an excellent feature for an idle system. L1 is used during Package C-States when its latency is hidden by other components during a wakeup.

KTI Prefetch

Keizer Technology Interconnect (KTI) is also known as the Intel Ultra Path Interconnect (UPI) technology. Select Enabled for the KTI prefetcher to preload the L1 cache with data deemed relevant, which allows the memory read to start earlier on a DDR bus in an effort to reduce latency. Select Auto for the KTI prefetcher to automatically preload the L1 cache with relevant data whenever it is needed. The options are Disabled, Enabled, and **Auto**.

IO Directory Cache (IODC)

This feature allows the IODC to generate snoops instead of generating memory lockups for remote IIO (InvltoM) and/or WCiLF (Cores). Select Auto for the IODC to generate snoops (instead of memory lockups) for WCiLF (Cores). The options are Disabled, **Auto**, Enable for Remote InvltoM Hybrid Push, Enable for Remote InvltoM AllocFlow, Enable for Remote InvltoM Hybrid AllocNonAlloc, and Enable for Remote InvltoM and Remote WCiLF.

SNC

Sub NUMA Clustering (SNC) is a feature that breaks up the LLC into clusters based on address range. Each cluster is connected to a subset of the memory controller. Enable this feature to improve average latency and reduce memory access congestion for higher performance. The options are Disabled, Enabled, and **Auto**. This feature is CPU-dependent.

Note: This feature is NOT available when "Workload Profile" is set to I/O, Virtualization, or Telco FlexRAN.

XPT Prefetch

XPT Prefetch is a feature that speculatively makes a copy to the memory controller of a read request being sent to the LLC. If the read request maps to the local memory address and the recent memory reads are likely to miss the LLC, a speculative read is sent to the local memory controller. The options are Disabled, Enabled, and **Auto**.

Stale AtoS

The in-memory directory has three states: I, A, and S states. The I (-invalid) state indicates that the data is clean and does not exist in the cache of any other sockets. The A (-snoop All) state indicates that the data may exist in another socket in an exclusive or modified state. The S state

(-Shared) indicates that the data is clean and may be shared in the caches across one or more sockets. When the system is performing "read" on the memory and if the directory line is in A state, we must snoop all other sockets because another socket may have the line in a modified state. If this is the case, a "snoop" will return the modified data. However, it may be the case that a line "reads" in an A state, and all the snoops come back with a "miss." This can happen if another socket reads the line earlier and then has silently dropped it from its cache without modifying it. If "Stale AtoS" is enabled, a line will transition to the S state when the line in the A state returns only snoop misses. That way, subsequent reads to the line will encounter it in the S state and will not have to snoop, saving the latency and snoop bandwidth. Stale "AtoS" may be beneficial in a workload where there are many cross-socket reads. The options are Disabled, Enabled, and **Auto**.

LLC Dead Line Alloc

Select Enabled to optimally fill the dead lines in the LLC. The options are Disabled, **Enabled**, and Auto.

Memory Configuration Menu

▶ **Memory Configuration**

This submenu is used to configure the Integrated Memory Controller (IMC) settings.

Enforce DDR Memory Frequency POR

Select Enforce POR to enforce Plan of Record (POR) restrictions for DDR memory frequency and voltage programming. The options are **Enforce POR**, Enforce Stretch Goals, and Disabled.

Host Memory Frequency

Use this feature to set the maximum memory frequency for onboard memory modules. The options are **Auto**, 4800, 5200, 5600, 6000, 6400, and 7200. Note that the available options are CPU-dependent.

Global Scrambling

Select Enabled to enable data scrambling to enhance system performance and data integrity. The options are Disabled and **Enabled**.

Memory Topology Menu

▶ **Memory Topology**

This submenu displays the information of onboard memory modules as detected by the BIOS, for example:

P1-DIMMA1: 5600MT/s Hynix SRx8 16GB RDIMM

Memory Map Menu

▶ **Memory Map**

Intel(R) Flat Memory Mode Support

Enable this feature to allow hardware-managed data movement between DDR5 and CXL memory, making total memory capacity visible to your system. The options are **Disabled** and Enabled.

DDR CXL Heterogeneous Interleave Support

Select Enabled to support heterogeneous interleaving for physical DDR5 and CXL memory. The options are **Disabled** and Enabled.

Memory RAS Configuration Menu

▶ **Memory RAS Configuration**

Use this submenu to configure the memory mirroring, Reliability Availability Serviceability (RAS) settings.

Mirror Mode

Use this feature to configure the mirror mode settings for all 1LM/2LM memory modules in the system to create a duplicate copy of data stored in the memory to increase memory security. It will reduce the memory capacity into half. The options are **Disabled** and Full Mirror Mode.

Note: This feature is available when "UEFI ARM Mirror" is set to Disabled.

UEFI ARM Mirror

If this feature is set to Enabled, mirror mode configuration settings for UEFI-based Address Range memory will be enabled upon system boot. This will create a duplicate copy of data stored in the memory to increase memory security, but it will reduce the memory capacity into half. The options are **Disabled** and Enabled. The Address Range Mirroring (ARM) feature supports partial memory mirroring. This feature is CPU-dependent.

Note: This feature is available when "Mirror Mode" is set to Disabled.

Mirror TAD0

Use this feature to enable the mirror mode on the entire memory for Target Address Decoder 0 (TAD0). The options are **Disabled** and Enabled. This feature is CPU-dependent.

Note: This feature is available when "Mirror Mode" is set to Disabled.

ARM Mirror Percentage (Available when "UEFI ARM Mirror" is set to Enabled)

Use this feature to set the percentage of memory space to be used for UEFI ARM mirroring for memory security enhancement. The default setting is **2500**.

Correctable Error Threshold

Use this feature to specify the threshold value for correctable memory-error logging, which sets a limit on the maximum number of events that can be logged in the memory error log at a given time. The default setting is **512**.

Note: This feature is available when "Memory PFA Support" is set to Disabled.

Leaky Bucket Low Bit

Use this feature to set the Low Bit value for the Leaky Bucket algorithm, which is used to check the data transmissions between CPU sockets and the memory controller. The default setting is **12**.

Leaky Bucket High Bit

Use this feature to set the High Bit value for the Leaky Bucket algorithm, which is used to check the data transmissions between CPU sockets and the memory controller. The default setting is **13**.

ADDDC Sparing (Available when populating 1Rx4, 2Rx4, and 4Rx4 DIMMs and when "Memory PFA Support" is set to Disabled)

Select Enabled for Adaptive Double Device Data Correction (ADDDC) support, which will not only provide memory error checking and correction but will also prevent the system from issuing a performance penalty before a device fails. Note that virtual lockstep mode will only start to work for ADDDC after a faulty DRAM module is spared. The options are Disabled and **Enabled**.

DDR PPR Type

Post Package Repair (PPR) is a new feature available for the DDR4/DDR5 technology. PPR provides additional spare capacity within a DDR4/DDR5 DRAM module that is used to replace faulty cell areas detected during system boot. PPR offers two types of memory repairs. Soft Post Package Repair (sPPR) provides a quick, temporary fix on a raw element in a bank group of a DDR4/DDR5 DRAM device, while hard Post Package Repair (hPPR) will take a longer time to provide a permanent repair on a raw element. The options are PPR Disabled, **Hard PPR**, and Soft PPR.

Note: This feature is available when "Memory PFA Support" is set to Disabled.

Enhanced PPR

Use this feature to set advanced memory test. Select Enabled to always execute for every boot. The options are **Disabled**, Enabled, and Persistent.

Memory PFA Support (Available when the DCMS key is activated)

Select Enabled to enable memory Predictive Failure Analysis (PFA) support. PFA can be used to avoid uncorrectable faults on the same memory page. The options are **Disabled** and Enabled.

Security Configuration Menu**▶ Security Configuration**

Memory Encryption (TME) [Outputs]

The following information is displayed.

- MSE activation state
- MK-TME activation state
- CI activation state
- Cryptographic Algorithm configured

Memory Encryption (TME) [Inputs]

Memory Encryption (TME)

Select Enabled for Intel Total Memory Encryption (TME) support to enhance memory data security. The options are **Disabled** and Enabled.

Total Memory Encryption Multi-Tenant (TME-MT)

Use this feature to support tenant-provided (SW-provided) keys. The options are **Disabled** and Enabled.

Memory Integrity

Use this feature to enable TME-MT memory integrity protection for memory transactions. The options are **Disabled** and Enabled.

The following information is displayed.

- KEY stock amount
- TME-MT key ID bits

TME Encryption Algorithm

Use this feature to set the TME encryption algorithm. The options are AES-XTS-128 and **AES-XTS-256**.

Trust Domain Extensions (TDX) [Outputs]

The following information is displayed.

- TDX activation state

Trust Domain Extensions (TDX) [Inputs]

Trust Domain Extensions (TDX) (Available when your motherboard supports Intel TDX)

Use this feature to enable Intel Trust Domain Extensions (TDX) technology support to enhance control of data security. The options are **Disabled** and Enabled.

Note: To support TDX features, DIMM population must be symmetric across integrated Memory Controllers (IMCs) and at least DIMMs per socket. For each memory controller, populating the first slots (Px-DIMMX1 or DIMMX1 depending on the motherboard design) in all channels is required. Refer to memory population below for your motherboard.

Trust Domain Extensions - Connect (TDX Connect) (Available when "Trust Domain Extensions (TDX)" is set to Enabled)

Use this feature to enable Intel TDX Connect support to improve I/O virtualization by removing the need to establish a secure TD-Device transport-level session. The options are **Disabled** and Enabled. This feature is CPU-dependent.

TDX Secure Arbitration Mode Loader (SEAM Loader) (Available when your motherboard supports Intel TDX and when "Trust Domain Extensions (TDX)" is set to Enabled)

The SEAM Loader (SEAMLDR) is used to load and update Intel TDX modules into the SEAM memory range by verifying the digital signature. The options are **Disabled** and Enabled.

TME-MT/TDX Key Split (Available when "Trust Domain Extensions (TDX)" is set to Enabled)

Use this feature to set the number of bits for TDX. The other bits will be used by TME-MT. The default setting is **1**.

The following information is displayed when "Trust Domain Extensions (TDX)" is set to Enabled.

- TME-MT Keys:
- TDX Keys:

Processor Reserved Memory [Capabilities]

The following information is displayed.

- PRMRR Min Size per domain
- PRMRR Max Size per domain

Processor Reserved Memory [Outputs]

The following information is displayed.

- PRMRR Size per domain
- PRM Size per socket
- PRM Size per system

Software Guard Extensions (SGX) [Outputs]

The following information is displayed when your motherboard supports SGX.

- SGX activation state
- SGX error code [HEX]

Software Guard Extensions (SGX) [Inputs]

The following features are available when your motherboard supports SGX.

Note: To support SGX features, DIMM population must be symmetric across Integrated Memory Controllers (IMCs) and at least DIMMs per socket. For each memory controller, populating the first slots (Px-DIMMX1 or DIMMX1 depending on the motherboard design) in all channels is required. Refer to memory population below for your motherboard.

SGX Factory Reset

Use this feature to perform an SGX factory reset to delete all registration data and force an Initial Platform Establishment flow. Reboot the system for the changes to take effect. The options are **Disabled** and Enabled.

SW Guard Extensions (SGX)

Use this feature to enable Intel Software Guard Extensions (SGX) support. Intel SGX is a set of extensions that increases the security of application code and data by using enclaves in memory to protect sensitive information. The options are **Disabled** and Enabled.

SGX Package Info In-Band Access

Setting this feature to Enabled is required before the BIOS provides software with the key blobs, which are generated for each CPU package. The options are **Disabled** and Enabled.

SGX PRMRR Size Requested (Available when "SW Guard Extensions (SGX)" is set to Enabled)

Use this feature to set the Processor Reserved Memory Range Register (PRMRR) size. The options are **Auto**, 128M, 256M, 512M, 1G, 2G, 4G, 8G, 16G, 32G, 64G, 128G, 256G, and 512G. Note that the available options are based on your motherboard features, memory size, and memory map.

SGX QoS (Available when "SW Guard Extensions (SGX)" is set to Enabled)

Use this feature to enable Intel SGX Quality of Service (QoS) support. QoS can enhance network performance by prioritizing network traffic. The options are Disabled and **Enabled**.

Select Owner EPOCH Input Type (Available when "SW Guard Extensions (SGX)" is set to Enabled)

Owner EPOCH is used as a parameter to add personal entropy into the key derivation process. A correct Owner EPOCH is required to have access to personal data previously sealed by other platform users. There are two Owner EPOCH modes. One is New Random Owner EPOCH, and the other is manually entered by the user. Each EPOCH is 64-bit. The options are **SGX Owner EPOCH deactivated**, Change to New Random Owner EPOCHs, and Manual User Defined Owner EPOCHs.

Note: Changing the Owner EPOCH value will lose the data in enclaves.

Software Guard Extensions Epoch 0

Use this feature to enter the EPOCH value. The default setting is **0**.

Note: This feature is available when "SW Guard Extensions (SGX)" is set to Enabled. This feature is NOT available when "Select Owner EPOCH Input Type" is set to SGX Owner EPOCH deactivated.

Software Guard Extensions Epoch 1

Use this feature to enter the EPOCH value. The default setting is **0**.

Note: This feature is available when "SW Guard Extensions (SGX)" is set to Enabled. This feature is NOT available when "Select Owner EPOCH Input Type" is set to SGX Owner EPOCH deactivated.

SGXLEPUBKEYHASHx Write Enable (Available when "SW Guard Extensions (SGX)" is set to Enabled)

Use this feature to enable writes to SGXLEPUBKEYHASH[3..0] from OS/SW. The options are Disabled and **Enabled**. Only those CPUs that support the Intel SGX Flexible Launch Control (FLC) feature have SGXLEPUBKEYHASH, which contains the hash of the public key for the SGX Launch Enclave (LE) to be signed with.

SGXLEPUBKEYHASH0 (Available when both "SW Guard Extensions (SGX)" and "SGXLEPUBKEYHASHx Write Enable" are set to Enabled)

Use this feature to enter the bytes 0–7 of SGX Launch Enclave Public Key Hash.

SGXLEPUBKEYHASH1 (Available when both "SW Guard Extensions (SGX)" and "SGXLEPUBKEYHASHx Write Enable" are set to Enabled)

Use this feature to enter the bytes 8–15 of SGX Launch Enclave Public Key Hash.

SGXLEPUBKEYHASH2 (Available when both "SW Guard Extensions (SGX)" and "SGXLEPUBKEYHASHx Write Enable" are set to Enabled)

Use this feature to enter the bytes 16–23 of SGX Launch Enclave Public Key Hash.

SGXLEPUBKEYHASH3 (Available when both "SW Guard Extensions (SGX)" and "SGXLEPUBKEYHASHx Write Enable" are set to Enabled)

Use this feature to enter the bytes 24–31 of SGX Launch Enclave Public Key Hash.

SGX Auto MP Registration (Available when "SW Guard Extensions (SGX)" is set to Enabled)

Use this feature to enable/disable SGX Auto Multi-Package Registration Agent (MPA) running automatically at boot time. The options are **Disabled** and Enabled.

I/O Configuration Menu

► I/O Configuration

PCIe Completion Timeout

Use this feature to set the PCIe completion timeout. The options are 50us to 50ms, 50us to 100us, 1ms to 10ms, 16ms to 55ms, 65ms to 210ms, **260ms to 900ms**, 1s to 3.5s, and Disabled.

PCIe ASPM Support (Global)

Use this feature to disable the Active State Power Management (ASPM) support for all PCIe root ports. The options are **Disabled** and Auto.

PRM Feature Control

Use this feature to enable the Platform Runtime Mechanism (PRM). The PRM is a mechanism to reduce the System Management Mode (SMM) usages and to provide an alternate means to invoke native code through the Advanced Configuration and Power Interface (ACPI) context of runtime events. The options are **Disabled** and Enabled.

Equalization Bypass To Highest Rate

Set this feature to Enabled to reduce the link training time for PCIe 5.0 device by skipping equalization of intermediate data rates. The options are Disabled and **Enabled**.

NVMe Mode Switch

When this feature is set to Auto, VMD support will be automatically enabled when a VROC key is detected by the BIOS. The options are Manual, VMD, and **Auto**. This feature is available for configuration when the system supports a VROC key.

PCIe PLL SSC

Select Enabled for PCIe Spread Spectrum Clocking (SSC) support, which allows the BIOS to monitor and attempt to reduce the level of electromagnetic interference caused by the components whenever needed. The options are **Disabled** and Enabled. The available options are CPU-dependent.

Snoop Response Hold Off for PCIe Stack

Use this feature to set the I/O snoop response hold-off value to improve throughput and reduce latency. The default setting is **9**. The valid range is 0 to F. Set this feature to 0 to disable the hold-off time.

CXL Security Level

By defining security protocols, CXL standards provide protection against the data security threats. Use this feature to set the CXL security level for data transiting the CXL link. The options are Fully Trusted, Partially Trusted, Untrusted, and **Auto**.

- Fully Trusted: This option allows the CXL device to access CXL.\$ for both host-attached and device-attached memory ranges in the write-back (WB) address space.
- Partially Trusted: This option allows the CXL device to access CXL.\$ for device-attached memory ranges only.
- Untrusted: If this option is selected, the host (your system) will abort all requests on CXL.\$.
- Auto: This option is based on Si Compatibility.

CXL Header Bypass

Use this feature to enable the CXL header bypass. The options are **Disabled** and Enabled.

CPU1 Configuration Menu

► CPU1 Configuration

► PCI Express 0 / PCI Express 1 / PCI Express 2 / PCI Express 3 / PCI Express 4 / PCI Express 5

Note: The number of PCIe slots and the slot naming can differ depending on the PCIe devices connected to your motherboard.

Intel VMD Technology

When this feature is set to Enabled, VMD support will be automatically enabled when a VROC key is detected by the BIOS. The options are **Disabled** and Enabled. This feature is available for configuration when the system supports a VROC key.

Notes:

- This feature is available when "NVMe Mode Switch" is set to Manual.
- After you've enabled VMD in the BIOS on a PCIe slot, this PCIe slot will be dedicated for VMD use only, and it will no longer support any PCIe device. To re-activate this slot for PCIe use, disable VMD in the BIOS.

Bifurcation

This feature is CPU-dependent. Use this feature to configure the PCIe Bifurcation setting for the PCIe port you specified. The options are **Auto**, x4x4x4x4, x4x4x8, x8x4x4, x8x8, and x16.

► PCI Express 5 Port A/Port C/Port E/Port G

Note: The number of PCIe slots and the slot naming can differ depending on the PCIe devices connected to your motherboard.

Requested Link Speed

Use this feature to configure the link speed of the PCIe port you specified. The options are **Auto**, Gen 1 (2.5 GT/s), Gen 2 (5 GT/s), Gen 3 (8 GT/s), Gen 4 (16 GT/s), and Gen 5 (32 GT/s).

The following information is displayed.

- Max Link Width
- Current Link Width
- Current Link Speed

Data Link Feature Exchange

Use this feature to enable data link feature negotiation in the Data Link Feature Capabilities (DLFCAP) register. The options are Disabled and **Enabled**.

PCIe Port Max Payload Size

Use this feature to configure the maximum payload size supported in PCIe device capabilities register for the device installed in the PCIe port. The options are 128B, 256B, 512B, and **Auto**.

MCTP

Enable this feature, Management Component Transport Protocol (MCTP), to support communications between devices in a platform management subsystem. MCTP's underlying device buses include SMBus/I²C, serial links, PCIe, and USB. The options are Disabled and **Enabled**.

Equalization Bypass To Highest Rate

Set this feature to Enabled to reduce the link training time for PCIe 5.0 device by skipping equalization of intermediate data rates. The options are Disabled and **Enabled**.

Intel VMD Technology

When this feature is set to Enabled, VMD support will be automatically enabled when a VROC key is detected by the BIOS. The options are **Disabled** and Enabled. This feature is available for configuration when the system supports a VROC key.

Intel VT for Directed I/O (VT-d) Menu

► Intel VT for Directed I/O (VT-d)

Note: This submenu is NOT available when "Workload Profile" is set to Virtualization.

Kernel DMA Protection

Select Enabled to notify OS to enable DMA protection after the system has booted by setting DMA_CTRL_PLATFORM_OPT_IN_FLAG in the DMAR ACPI table. The options are Enabled and **Disabled**. (DMA is the abbreviation for Direct Memory Access. DMAR is the abbreviation for DMA Remapping Reporting.)

Pre-boot DMA Protection

Select Enabled to establish DMA protection during pre-boot processing by setting DMA_CTRL_PLATFORM_OPT_IN_FLAG in the DMAR ACPI table. The options are Enabled and **Disabled**.

PCIe ACSCTL

Select Enabled to program ACS control to Chipset PCIe Root Port bridges. Select Disabled to program ACS control to all PCIe Root Port bridges. The options are Enabled and **Disabled**.

PCIe Leaky Bucket Configuration Menu

► PCIe Leaky Bucket Configuration

Gen2 Link Degradation

Use this feature to enable PCIe Gen2 link degradation. The options are Disabled and **Enabled**.

Note: The default setting is Enabled when your motherboard supports PCIe Gen2 link. Otherwise, the default setting is Disabled.

Gen3 Link Degradation

Use this feature to enable PCIe Gen3 link degradation. The options are Disabled and **Enabled**.

Note: The default setting is Enabled when your motherboard supports PCIe Gen3 link. Otherwise, the default setting is Disabled.

Gen4 Link Degradation

Use this feature to enable PCIe Gen4 link degradation. The options are Disabled and **Enabled**.

Note: The default setting is Enabled when your motherboard supports PCIe Gen4 link. Otherwise, the default setting is Disabled.

Gen5 Link Degradation

Use this feature to enable PCIe Gen5 link degradation. The options are Disabled and **Enabled**.

Note: The default setting is Enabled when your motherboard supports PCIe Gen5 link. Otherwise, the default setting is Disabled.

Super IO Configuration Menu

► Super IO Configuration

The following information is displayed.

- Super IO Chip

Note: This submenu is available when your system supports this feature.

Serial Port 1 Configuration Menu

► Serial Port 1 Configuration

Serial Port 1

Select Enabled to enable serial port 1. The options are Disabled and **Enabled**.

Device Settings (Available when "Serial Port 1" above is set to Enabled)

This feature displays the base I/O port address and the Interrupt Request address of serial port 1.

Change Settings (Available when "Serial Port 1" above is set to Enabled)

Use this feature to specify the base I/O port address and the Interrupt Request address of serial port 1. Select Auto for the BIOS to automatically assign the base I/O and IRQ address to serial port 1. The options are **Auto**, (IO=3F8h; IRQ=4;), (IO=3F8h; IRQ=3,4,5,6,7,9,10,11,12;), (IO=2F8h; IRQ=3,4,5,6,7,9,10,11,12;), (IO=3E8h; IRQ=3,4,5,6,7,9,10,11,12;), and (IO=2E8h; IRQ=3,4,5,6,7,9,10,11,12;).

Serial Port 2 Configuration Menu

► Serial Port 2 Configuration

Note: It can be "Serial Port 2 Configuration" or "SOL Configuration" based on your system support.

Serial Port 2/SOL ("Serial Port 2" or "SOL" based on your system support)

Select Enabled to enable serial port 2 (or SOL). The options are Disabled and **Enabled**.

Device Settings (Available when "Serial Port 2/SOL" above is set to Enabled)

This feature displays the base I/O port address and the Interrupt Request address of serial port 2 (or SOL).

Change Settings (Available when "Serial Port 2/SOL" above is set to Enabled)

Use this feature to specify the base I/O port address and the Interrupt Request address of serial port 2 (or SOL). Select Auto for the BIOS to automatically assign the base I/O and IRQ address to serial port 2 (or SOL).

The options are **Auto**, (IO=2F8h; IRQ=3;), (IO=3F8h; IRQ=3,4,5,6,7,9,10,11,12;), (IO=2F8h; IRQ=3,4,5,6,7,9,10,11,12;), (IO=3E8h; IRQ=3,4,5,6,7,9,10,11,12;), and (IO=2E8h; IRQ=3,4,5,6,7,9,10,11,12;).

Serial Port 2 Attribute (Available for Serial Port 2 only)

Select SOL to use serial port 2 as a Serial Over LAN (SOL) port for console redirection. The options are **SOL** and COM.

Serial Port Console Redirection Menu

► Serial Port Console Redirection

COM1 (Available when your system supports the serial port of COM1)

Console Redirection

Select Enabled to enable COM port 1 for Console Redirection, which allows a client machine to be connected to a host machine at a remote site for networking. The options are **Disabled** and Enabled.

Note: This feature will be set to Enabled if there is no BMC support.

SOL/COM2

Note: This feature is available when your system supports serial port of SOL and/or COM2. The "SOL/COM2" here indicates a shared serial port, and SOL is used as the default.

Console Redirection

Select Enabled to use the SOL/COM2 port for Console Redirection. The options are Disabled and **Enabled**.

► Console Redirection Settings

Note: This submenu is available when "Console Redirection" for COM1 or SOL/COM2 is set to Enabled.

Terminal Type

Use this feature to select the target terminal emulation type for Console Redirection. Select VT100 to use the ASCII character set. Select VT100+ to add color and function key support. Select ANSI to use the extended ASCII character set. Select VT-UTF8 to use UTF8 encoding to map Unicode characters into one or more bytes. The options are VT100, **VT100+**, VT-UTF8, and ANSI.

Bits Per Second

Use this feature to set the transmission speed for a serial port used in Console Redirection. Make sure that the same speed is used in the host computer and the client computer. A lower transmission speed may be required for long and busy lines. The options are 9600, 19200, 38400, 57600, and **115200** (bits per second).

Data Bits

Use this feature to set the data transmission size for Console Redirection. The options are 7 and **8** (bits).

Parity

A parity bit can be sent along with regular data bits to detect data transmission errors. Select Even if the parity bit is set to 0 and the number of 1s in data bits is even. Select Odd if the parity bit is set to 0 and the number of 1s in data bits is odd. Select None if you do not want to send a parity bit with your data bits in transmission. Select Mark to add a mark as a parity bit to be sent along with the data bits. Select Space to add a space as a parity bit to be sent with your data bits. The options are **None**, Even, Odd, Mark, and Space.

Stop Bits

A stop bit indicates the end of a serial data packet. Select 1 (stop bit) for standard serial data communication. Select 2 (stop bits) if slower devices are used. The options are **1** and **2**.

Flow Control

Use this feature to set the flow control for Console Redirection to prevent data loss caused by buffer overflow. Send a "Stop" signal to stop sending data when the receiving buffer is full. Send a "Start" signal to start sending data when the receiving buffer is empty. The options are **None** and Hardware RTS/CTS.

VT-UTF8 Combo Key Support

Select Enabled to enable VT-UTF8 Combination Key support for ANSI/VT100 terminals. The options are Disabled and **Enabled**.

Recorder Mode

Select Enabled to capture the data displayed on a terminal and send it as text messages to a remote server. The options are **Disabled** and Enabled.

Resolution 100x31

Select Enabled for extended-terminal resolution support. The options are Disabled and **Enabled**.

Putty KeyPad

Use this feature to select the function key and keypad settings on Putty, which is a terminal emulator designed for the Windows OS. The options are **VT100**, LINUX, XTERMR6, SCO, ESCN, and VT400.

Serial Port for Out-of-Band Management/Windows Emergency Management Services (EMS)

Use the features below to configure Console Redirection settings to support Out-of-Band Serial Port management.

Console Redirection EMS

Select Enabled to use the SOL port for Console Redirection. The options are **Disabled** and Enabled.

► Console Redirection Settings

Note: This submenu is available when "Console Redirection EMS" is set to Enabled.

Out-of-Band Mgmt Port

Use this feature to select a serial port in a client server to be used by the Microsoft Windows Emergency Management Services (EMS) to communicate with a remote host server. The options are **COM1** and SOL/COM2. Note that the option of SOL/COM2 indicates a shared serial port. SOL is available with BMC support.

Terminal Type EMS

Use this feature to select the target terminal emulation type for Console Redirection. Select VT100 to use the ASCII character set. Select VT100+ to add color and function key support. Select ANSI to use the extended ASCII character set. Select VT-UTF8 to use UTF8 encoding to map Unicode characters into one or more bytes. The options are VT100, VT100+, **VT-UTF8**, and ANSI.

Bits Per Second EMS

This feature sets the transmission speed for a serial port used in Console Redirection. Make sure that the same speed is used in the host computer and the client computer. A lower transmission speed may be required for long and busy lines. The options are 9600, 19200, 57600, and **115200** (bits per second).

Flow Control EMS

Use this feature to set the flow control for Console Redirection to prevent data loss caused by buffer overflow. Send a "Stop" signal to stop sending data when the receiving buffer is full. Send a "Start" signal to start sending data when the receiving buffer is empty. The options are **None**, Hardware RTS/CTS, and Software Xon/Xoff.

The following information is displayed.

- **Data Bits EMS**
- **Parity EMS**
- **Stop Bits EMS**

Network Stack Configuration Menu

► Network Stack Configuration

Network Stack

Select Enabled to enable Preboot Execution Environment (PXE) or Unified Extensible Firmware Interface (UEFI) for network stack support. The options are Disabled and **Enabled**.

IPv4 PXE Support (Available when "Network Stack" is set to Enabled)

Select Enabled to enable IPv4 PXE boot support. If this feature is disabled, it will not create the IPv4 PXE boot option. The options are Disabled and **Enabled**.

IPv4 HTTP Support (Available when "Network Stack" is set to Enabled)

Select Enabled to enable IPv4 HTTP boot support. If this feature is disabled, it will not create the IPv4 HTTP boot option. The options are **Disabled** and Enabled.

IPv6 PXE Support (Available when "Network Stack" is set to Enabled)

Select Enabled to enable IPv6 PXE boot support. If this feature is disabled, it will not create the IPv6 PXE boot option. The options are Disabled and **Enabled**.

IPv6 HTTP Support (Available when "Network Stack" is set to Enabled)

Select Enabled to enable IPv6 HTTP boot support. If this feature is disabled, it will not create the IPv6 HTTP boot option. The options are **Disabled** and Enabled.

PXE Boot Wait Time (Available when "Network Stack" is set to Enabled)

Use this feature to set the wait time (in seconds) upon which the system BIOS will wait for you to press the <ESC> key to abort PXE boot instead of proceeding with PXE boot by connecting to a network server immediately. Press the <+> or <-> key on your keyboard to change the value. The default setting is **0**.

Media Detect Count (Available when "Network Stack" is set to Enabled)

Use this feature to set the wait time (in seconds) for the BIOS ROM to detect the presence of a LAN media either via the Internet connection or via a LAN port. Press the <+> or <-> key on your keyboard to change the value. The default setting is **1**.

MAC:(MAC address)-IPv4 Network Configuration Menu**▶ MAC:(MAC address)-IPv4 Network Configuration****Configured**

Enable this feature to configure network addresses for DHCP, local IP address, local netmask, local gateway, and local DNS server. The options are **Disabled** and Enabled.

Enable DHCP (Available when "Configured" is set to Enabled)

Select Enabled to support Dynamic Host Configuration Protocol (DHCP), which allows the BIOS to search for a DHCP server attached to the network and request the next available IP address for this computer. The options are **Disabled** and Enabled.

Local IP Address (Available when "Configured" is set to Enabled and "Enable DHCP" is set to Disabled)

Use this feature to enter an IP address for the local machine.

Local NetMask (Available when "Configured" is set to Enabled and "Enable DHCP" is set to Disabled)

Use this feature to set the netmask for the local machine.

Local Gateway (Available when "Configured" is set to Enabled and "Enable DHCP" is set to Disabled)

Use this feature to set the gateway address for the local machine.

Local DNS Servers (Available when "Configured" is set to Enabled and "Enable DHCP" is set to Disabled)

Use this feature to set the Domain Name System (DNS) server address for the local machine.

Save Changes and Exit

Press <Enter> to save changes and exit.

MAC:(MAC address)-IPv6 Network Configuration Menu**▶ MAC:(MAC address)-IPv6 Network Configuration****▶ Enter Configuration Menu**

The following information is displayed.

- Interface Name
- Interface Type
- MAC address
- Host address
- Route Table
- Gateway addresses
- DNS addresses

Interface ID

Use this feature to change/enter the 64-bit alternative interface ID for the device. The string format is colon separated. The default setting is the MAC address above.

DAD Transmit Count

Use this feature to set the number of consecutive neighbor solicitation messages that have been sent while performing duplicate address detection on a tentative address. The default setting is **1**.

Policy

Use this feature to select how the policy is to be configured. The options are **automatic** and **manual**.

▶ Advanced Configuration

Note: This submenu is available when "Policy" is set to manual.

New IPv6 address: Use this feature to enter the IPv6 address for the local machine.

New Gateway addresses: Use this feature to set the gateway address for the local machine.

New DNS addresses: Use this feature to set the DNS server address for the local machine.

Commit Changes and Exit: Press <Enter> to save changes and exit.

Discard Changes and Exit: Press <Enter> to discard changes and exit.

Save Changes and Exit

Press <Enter> to save changes and exit.

PCIe/PCI/PnP Configuration Menu

► PCIe/PCI/PnP Configuration

The following information is displayed.

- PCI Bus Driver Version

PCI Devices Common Settings:

Re-Size BAR Support

Use this feature to enable the Resizable BAR support. Resizable BAR is a PCIe interface technology that allows the CPU to access the entire frame buffer. With this technology, your system will be able to handle multiple CPU to GPU transfers simultaneously rather than queuing, which can improve the frame rate performance. The options are **Disabled** and **Enabled**.

SR-IOV Support (Unavailable when "Workload Profile" is set to Virtualization)

Select **Enabled** for Single-Root IO Virtualization support. The options are **Disabled** and **Enabled**.

ARI Support

Select **Enabled** for Alternative Routing-ID Interpretation (ARI) support. The options are **Disabled** and **Enabled**.

MMCFG Base

This feature determines how the lowest Memory Mapped Configuration (MMCFG) base is assigned to onboard PCI devices. The options are 1G, 1.5G, 1.75G, 2G, 2.25G, 3G, and **Auto**. The options of 2G and 2.25G are not available when the MMCFG size is 2G. The option of 3G

is not available when the MMCFG size is 1G or 2G.

MMCFG Size

Use this feature to set the MMCFG size. The options are 64M, 128M, 256M, 512M, 1G, 2G, and **Auto**. Note that the MMCFG size is based on the memory populated.

MMIO High Base

Use this feature to select the base memory size according to memory-address mapping for the I/O hub. The options are 248T, 120T, 88T, 60T, 30T, 56T, 40T, 32T, 24T, 16T, 4T, 2T, 1T, 512G, 3584T, and **Auto**. The options of 248T, 120T, 88T, 60T, 30T, and 3584T are CPU-dependent.

MMIO High Granularity Size

Use this feature to select the high memory size according to memory-address mapping for the I/O hub. The options are 1G, 4G, 16G, 32G, 64G, 256G, and **1024G**. This feature is motherboard-dependent.

Bus Master Enable

If this feature is set to Enabled, the PCI Bus Driver will enable the Bus Master Attribute for DMA transactions. If this feature is set to Disabled, the PCI Bus Driver will disable the Bus Master Attribute for Pre-Boot DMA protection. The options are Disabled and **Enabled**.

NVMe Firmware Source

Use this feature to select the NVMe firmware to support system boot. The options are Vendor Defined Firmware and **AMI Native Support**. The option of Vendor Defined Firmware is pre-installed on the drive and may resolve errata or enable innovative functions for the drive. The option of AMI Native Support is offered by the BIOS with a generic method. The default option is motherboard-dependent.

VGA Priority

Use this feature to select the graphics device to be used as the primary video display for system boot. The options are **Onboard** and Offboard.

Onboard Video Option ROM

Select EFI to boot the computer using the Extensible Firmware Interface (EFI) device installed on the onboard video port. The options are Disabled and **EFI**.

Onboard LAN1 Option ROM

Select EFI to boot the computer using the EFI device installed on LAN port 1. The options are Disabled and **EFI**.

Note: This feature is available when your motherboard supports onboard LAN ports.

Onboard LAN2 Option ROM

Use this feature to boot the computer using the EFI device installed on LAN port 2. Select Disabled to disable this feature. The default setting is **Disabled**.

Note: This feature is available when your motherboard supports onboard LAN ports and when "Onboard LAN1 Option ROM" is set to Disabled.

AOC-ATG-i2S LAN1 OPROM / Onboard SAS Option ROM / Onboard LAN1 Option ROM / Onboard NVMe1 Option ROM – Onboard NVMe24 Option ROM

Select EFI to boot the computer using the EFI device installed on the PCIe slot specified. The options are Disabled and **EFI**.

Note: The number of slots and slot naming vary based on your motherboard features.

ACPI Settings Menu

▶ ACPI Settings

NUMA

Use this feature to enable Non-Uniform Memory Access (NUMA) support to minimize memory access latencies. The options are Disabled and **Enabled**. This feature is CPU-dependent.

Virtual NUMA

Enable this feature to optimize the memory-access performance for VMware virtual machines. The options are **Disabled** and Enabled.

Note: This feature is NOT available when "Workload Profile" is set to Telco NFVI, Telco NFVI-FP, or Telco FlexRAN.

Number of Virtual NUMA Nodes (Available when "Virtual NUMA" is set to Enabled)

This feature displays the number of virtual NUMA nodes. A NUMA architecture divides hardware resources (including processors, memory, and I/O buses) into groups, called NUMA nodes. This feature indicates the available number of virtual NUMA nodes that can be assigned to the virtual machine. By default, this setting is automatically adjusted to match the physical NUMA topology.

WHEA Support

Select Enabled to support the Windows Hardware Error Architecture (WHEA) platform and provide a common infrastructure for the system to handle hardware errors within the Windows OS environment to reduce system crashes and to enhance system recovery and health monitoring. The options are Disabled and **Enabled**.

Trusted Computing Menu

► Trusted Computing

When the TPM 2.0 (either onboard or external) is detected by your system, the following information is displayed.

- TPM 2.0 Device Found
- Firmware Version:
- Vendor:

Note: This submenu is available when the TPM 2.0 (either onboard or external) is detected by the BIOS.

Security Device Support

Select Enabled to enable BIOS support for onboard security devices, which are not displayed in the OS. If this feature is set to Enabled, TCG EFI protocol and INT1A interface will not be available. The options are Disabled and **Enabled**.

When "Security Device Support" is set to Enabled and the TPM 2.0 (either onboard or external) is detected by the BIOS, the following information is displayed.

- Active PCR banks
- Available PCR banks

Note: The following features are available when the TPM 2.0 (either onboard or external) is detected by the BIOS.

SHA-1 PCR Bank (Available when "Security Device Support" is set to Enabled)

Select Enabled to enable SHA-1 PCR Bank support to enhance system integrity and data security. The options are Disabled and **Enabled**.

SHA256 PCR Bank (Available when "Security Device Support" is set to Enabled)

Select Enabled to enable SHA256 PCR Bank support to enhance system integrity and data security. The options are Disabled and **Enabled**.

SHA384 PCR Bank (Available when "Security Device Support" is set to Enabled)

Select Enabled to enable SHA384 PCR Bank support to enhance system integrity and data security. The options are **Disabled** and Enabled.

Pending Operation (Available when "Security Device Support" is set to Enabled)

Use this feature to schedule a TPM-related operation to be performed by the security TPM (either onboard or external) at the next system boot to enhance system data integrity. The options are **None** and TPM Clear.

Note: If this feature is used, your system will reboot to carry out a pending TPM operation.

Platform Hierarchy (Available when "Security Device Support" is set to Enabled)

Select Enabled for TPM Platform Hierarchy support, which allows the manufacturer to utilize the cryptographic algorithm to define a constant key or a fixed set of keys to be used for initial system boot. These early boot codes are shipped with the platform and are included in the list of "public keys." During system boot, the platform firmware uses the trusted public keys to verify a digital signature in an attempt to manage and control the security of the platform firmware used in a host system via the TPM (either onboard or external). The options are Disabled and **Enabled**.

Storage Hierarchy (Available when "Security Device Support" is set to Enabled)

Select Enabled for TPM Storage Hierarchy support that is intended to be used for non-privacy-sensitive operations by a platform owner such as an IT professional or the end user. Storage Hierarchy has an owner policy and an authorization value, both of which can be set and are held constant (-rarely changed) through reboots. This hierarchy can be cleared or changed independently of the other hierarchies. The options are Disabled and **Enabled**.

Endorsement Hierarchy (Available when "Security Device Support" is set to Enabled)

Select Enabled for Endorsement Hierarchy support, which contains separate controls to address the user's privacy concerns because the primary keys in the hierarchy are certified by the TPM key or by a manufacturer with restrictions on how an authentic TPM (either onboard or external) that is attached to an authentic platform can be accessed and used. A primary key can be encrypted and certified with a certificate created by using TPM2_ActivateCredential, which allows the user to independently enable "flag, policy, and authorization values" without involving other hierarchies. A user with privacy concerns can disable the endorsement hierarchy while still using the storage hierarchy for TPM applications, permitting the platform software to use the TPM. The options are Disabled and **Enabled**.

PH Randomization

Select Enabled for Platform Hierarchy (PH) Randomization support, which is used only during the platform developmental stage. This feature cannot be enabled in the production platforms. The options are **Disabled** and Enabled.

Supermicro BIOS-Based TPM Provision Support

Set this feature to Enabled to unlock the TPM. Save settings and exit the BIOS Setup utility. The Non-volatile (NV) indexes can be deleted after the system reboot. The options are **Disabled** and Enabled.

Supermicro KMS Server Configuration Menu

► Supermicro KMS Server Configuration

Note: Be sure to configure all the features in the submenu of Supermicro KMS Server Configuration and the feature of "KMS Security Policy" in the submenu of Super-Guardians Configuration so that your system can communicate with the KMS server.

TPM-KMS Support

This feature combines the capabilities of a hardware-based security module (TPM) with the Key Management Service (KMS) to enhance security by managing cryptographic keys and ensuring secure access to sensitive data. The options are **Disabled** and Enabled.

Supermicro KMS Server IP address

Use this feature to set the Supermicro KMS server IPv4 address in dotted-decimal notation.

Second Supermicro KMS Server IP address

Use this feature to set the second Supermicro KMS server IPv4 address in dotted-decimal notation.

Supermicro KMS TCP Port number

Use this feature to set the TCP port number used in the Supermicro KMS server. The valid range is 100–9999. The default setting is **5696**. Do not change the default setting unless a different TCP port number has been specified and used in the Supermicro KMS server.

KMS Time Out

Use this feature to enter the KMS server connecting time-out (in seconds). The default setting is **5** (seconds).

TimeZone

Use this feature to set the correct time zone. The default setting is **0** (not specified).

Client UserName

Press <Enter> to set the client identity (UserName). The length is 0–63 characters.

Client Password

Press <Enter> to set the client identity (Password). The length is 0–31 characters.

▶ CA Certificate

▶ Client Certificate

▶ Client Private Key

Use the three features above to enroll factory defaults or load the KMS Transport Layer Security (TLS) certificates, which are generated by the KMS server, from the file stored in the USB flash drive as shown below.

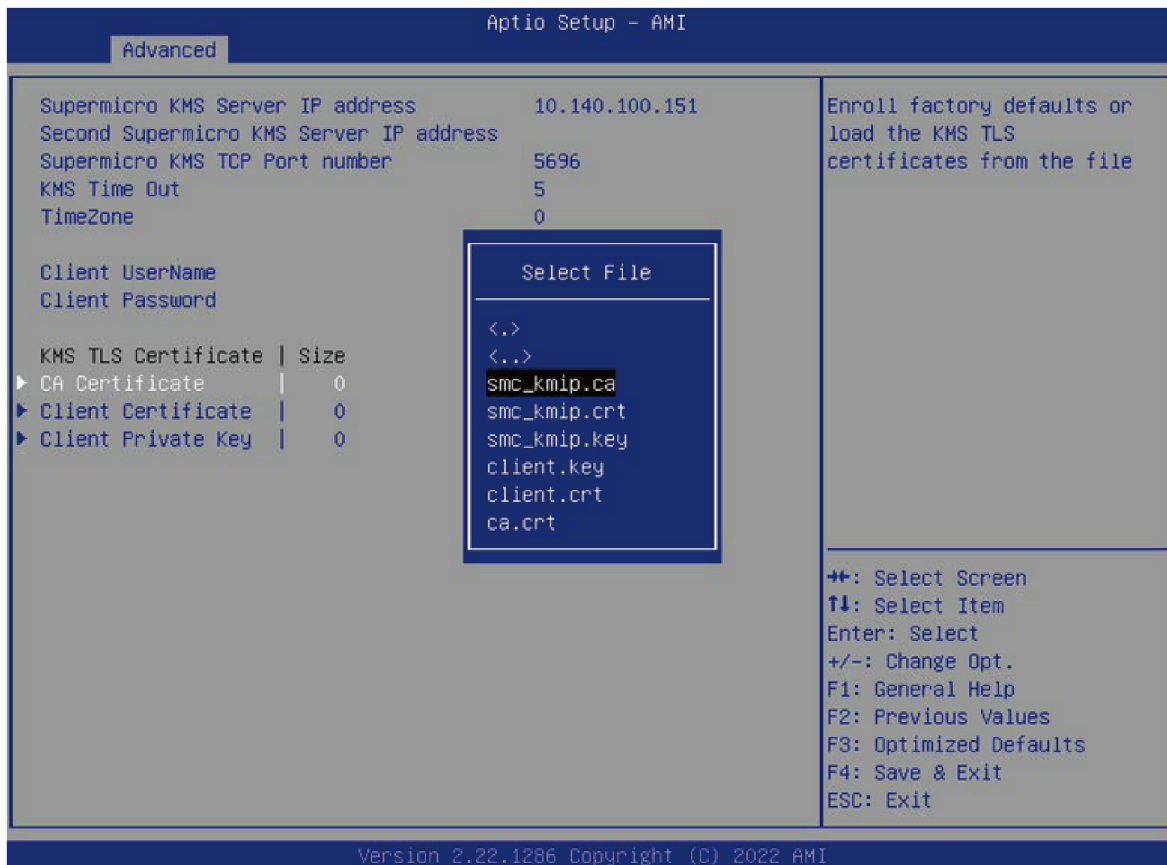

Private Key Password (Available when "Client Private Key" above has been set)

Use this feature to change the private key password.

Super-Guardians Configuration Menu

► Super-Guardians Configuration

Super-Guardians Protection Policy

Use this feature to enable the Super-Guardians Protection Policy. The options are **Storage**, **System**, and **System and Storage**. Set this feature to **Storage** to protect and have secure access to the Trusted Computing Group (TCG) NVMe devices with the Authentication-Key (AK). Set this feature to **System** to protect and have secure access to your system/motherboard with the AK. Set this feature to **System and Storage** to protect and have secure access to your system/motherboard/storage devices with the AK.

KMS Security Policy (Available when "TPM Security Policy" and "USB Security Policy" are set to Disabled)

Set this feature to **Enabled** to enable the KMS Security Policy. When this feature has not previously been set to **Enabled**, the options are **Disabled** and **Enabled**. Changes take effect after you save settings and reboot the system.

When this feature has previously been set to **Enabled**, the options are **Enabled**, **Reset**, and **Key Rotation**. Set this feature to **Key Rotation** to obtain an existing AK from the KMS server and create a new AK. To disable the KMS Security Policy, set this feature to **Reset**. When this feature is set to **Reset**, the system and TCG NVMe devices chosen in "Super-Guardians Protection Policy" will be in the unprotected mode.

Notes:

- Be sure that the KMS server is ready before configuring this feature.
- Use the professional KMS server solutions (e.g., Thales Server) or the Supermicro PyKMIP Software Package to establish the KMS server.

KMS Server Retry Count (Available when "TPM Security Policy" and "USB Security Policy" are set to Disabled)

Use this feature to specify how many times the system will attempt reconnecting to the KMS server. The valid range is 0–10. Press the <+> or <-> key on your keyboard to change the value. The default setting is **5**. If the value is 0, the system will retry infinitely.

TPM Security Policy (Available when "KMS Security Policy" and "USB Security Policy" are set to Disabled)

Set this feature to **Enabled** to enable the TPM Security Policy. When this feature has not previously been set to **Enabled**, the options are **Disabled** and **Enabled**. Changes take effect after you save settings and reboot the system.

When this feature has previously been set to Enabled, the options are **Enabled**, Reset, and Key Rotation. To disable the TPM Security Policy, set this feature to Reset. When this feature is set to Reset, the system and TCG NVMe devices chosen in "Super-Guardians Protection Policy" will be in the unprotected mode.

Note: The TPM 2.0 (either onboard or external) is required to configure this feature.

Load Authentication-Key (Available when "KMS Security Policy," "TPM Security Policy," and "USB Security Policy" are set to Disabled)

Use this feature to load the Authentication-Key. The options are **Disabled** and Enabled. Set this feature to Enabled. Changes take effect after you save settings and reboot the system. While booting, the BIOS will automatically load the Authentication- Key (filename: TPMAuth.bin) from the USB flash drive. Afterwards, the default setting will be set to Disabled by the BIOS.

Notes:

- Be sure to connect a USB flash drive with the Authentication-Key (filename: TPMAuth.bin) to your system before the system reboot.
- Be sure to save the Authentication-Key (filename: TPMAuth.bin) to the USB flash drive and keep a backup. Load the Authentication-Key (filename: TPMAuth.bin) after the TPM (either onboard or external) is detected by your system. Otherwise, the TPM function can not work properly.

Save Authentication-Key (Available when "TPM Security Policy" is set to Enabled)

Use this feature to save the Authentication-Key. The options are **Disabled** and Enabled. Set this feature to Enabled. Changes take effect after you save settings and reboot the system. While booting, the BIOS will automatically save the Authentication- Key (filename: TPMAuth.bin) to the USB flash drive. Afterwards, the default setting will be set to Disabled by the BIOS.

Note: Be sure to connect a USB flash drive to your system before the system reboot.

USB Security Policy (Available when "KMS Security Policy" and "TPM Security Policy" are set to Disabled)

Use this feature to enable the USB Security Policy. The options are **Disabled** and Enabled. Set this feature to Enabled. Changes take effect after you save settings and reboot the system. Connect a USB flash drive to your system before the system reboot. While booting, the BIOS will automatically create the USB Authentication-Key (filename: USBAuth.bin) and save it to the USB flash drive.

When this feature has been previously set to Enabled, the options are **Enabled** and Reset. To disable the USB Security Policy, set this feature to Reset. When this feature is set to Reset, the system and TCG NVMe devices chosen in "Super-Guardians Protection Policy" will be in the unprotected mode.

Note: Be sure to connect a USB flash drive to your system before configuring this feature. Save the USB Authentication-Key (filename: USBAuth.bin) to the USB flash drive and keep a backup.

HTTP Boot Configuration Menu

► HTTP Boot Configuration

HTTP Boot Policy

Use this feature to set the HTTP boot policy. The options are Apply to all LANs, **Apply to each LAN**, and Boot Priority #1 instantly.

HTTPS Boot Checks Hostname

Important: Disabling "HTTPS Boot Checks Hostname" is a violation of RFC 6125 and may expose you to Man-in-the-Middle Attacks. Supermicro is not responsible for any and all security risks incurred by you disabling this feature.

Enable this feature for HTTPS boot to check the hostname of the TLS certificates to see if it matches the host name provided by the remote server. The options are **Enabled** and Disabled (WARNING: Security Risk!!).

Priority of HTTP Boot

Instance of Priority 1: (Available when your motherboard supports this feature)

This feature sets the rank target port. The default setting is **1**.

Select IPv4 or IPv6

This feature specifies which connection the target LAN port should boot from. The options are **IPv4** and IPv6.

Boot Description

Use this feature to enter a boot description, which cannot be longer than 75 characters. Be sure to enter a boot description; otherwise, the boot option for the URI cannot be created.

Boot URI

Enter a Boot Uniform Research Identifier (URI) with 128 characters or shorter. This Boot URI determines how IPv4 Boot Option and IPv6 Boot Option will be created.

Instance of Priority 2: (Available when your motherboard supports this feature)

This feature sets the rank target port. The default setting is **0**.

Select IPv4 or IPv6 (Unavailable when "Instance of Priority 2:" above is set to 0)

This feature specifies which connection the target LAN port should boot from. The options are **IPv4** and **IPv6**.

Boot Description (Unavailable when "Instance of Priority 2:" above is set to 0)

Use this feature to enter a boot description, which cannot be longer than 75 characters. Please be sure to enter a boot description; otherwise, the boot option for the URI cannot be created.

Boot URI (Unavailable when "Instance of Priority 2:" above is set to 0)

Enter a Boot URI with 128 characters or shorter. This Boot URI determines how IPv4 Boot Option and IPv6 Boot Option will be created.

Intel(R) Ethernet Controller Menu

► Intel(R) Ethernet Controller (Ethernet controller) - (MAC address)

Notes:

- The Ethernet controller and MAC address shown above are based on your system features.
- This submenu is available when the LAN Option ROM type is EFI.

► NIC Configuration

Link Speed

Use this feature to set the connection speed of a selected LAN port. The options are **Auto Negotiated**, 10 Mbps Half, 10 Mbps Full, 100 Mbps Half, and 100 Mbps Full.

Wake On LAN

Set this feature to support system wake-up via the selected LAN port. If this feature is set to **Enabled**, the LAN port selected will be enabled when the system is powered on. The options are **Disabled** and **Enabled**.

LLDP Agent

Use this feature to enable or disable Link Layer Discovery Protocol (LLDP) agent support on a long-term basis. The LLDP, a vendor-neutral link layer protocol, is used by a network

device to identify itself and announce its capability to the neighboring devices in a network environment for networking. When disabling the LLDP agent in the firmware, the function of Data Center Bridging (DCB) will also be disabled. The options are Disabled and **Enabled**.

Blink LEDs

Use this feature to identify the physical network port by blinking the associated LEDs. The default setting is **0** (up to 15 seconds).

The following information is displayed.

- UEFI Driver
- Adapter PBA
- Device Name
- Chip Type
- PCI Device ID
- PCI Address
- Link Status
- MAC Address
- Virtual MAC Address

TLS Authenticate Configuration Menu

► TLS Authenticate Configuration

Use this submenu to configure Transport Layer Security (TLS) settings.

► Server CA Configuration

Use this feature to configure the client certificate that is to be used by the server.

► Enroll Certification

Use this feature to enroll the certificate in the system.

► Enroll Certification Using File

Use this feature to enroll the security certificate in the system by using a file.

► Commit Changes and Exit

Use this feature to save all changes and exit TLS settings.

▶ Discard Changes and Exit

Use this feature to discard all changes and exit TLS settings.

▶ Delete Certification

Use this feature to delete the certificate if a certificate has been enrolled in the system.

▶ Client Certification Configuration

Driver Health Menu

▶ Driver Health

This feature displays the health information of the drivers installed in your system, including LAN controllers, as detected by the BIOS. Select one and press <Enter> to see the details.

Note: This section is provided for reference only, for the driver health status will differ depending on the drivers installed in your system. It's also based on your system configuration and the environment that your system is operating in.

8.4 Event Logs

Use this menu to configure Event Logs settings.

Note: After making any changes in this section, please be sure to reboot the system for the changes to take effect.



Figure 8-3. Event Logs Page

▶ Change SMBIOS Event Log Settings

Note: Reboot the system for the changes in this section to take effect.

Enabling/Disabling Options

SMBIOS Event Log

Select Enabled to enable System Management BIOS (SMBIOS) Event Logging during system boot. The options are Disabled and **Enabled**.

Erasing Settings

Erase Event Log (Available when "SMBIOS Event Log" is set to Enabled)

Select No to keep the event log without erasing it upon next system bootup. Select (Yes, Next reset) to erase the event log upon next system reboot. The options are **No**, (Yes, Next reset), and (Yes, Every reset).

When Log is Full (Available when "SMBIOS Event Log" is set to Enabled)

Select Erase Immediately to immediately erase all errors in the SMBIOS event log when the event log is full. Select Do Nothing for the system to do nothing when the SMBIOS event log is full. The options are **Do Nothing** and Erase Immediately.

SMBIOS Event Log Standard Settings

Log System Boot Event (Available when "SMBIOS Event Log" is set to Enabled)

Select Enabled to log system boot events. The options are Enabled and **Disabled**.

MECI (Available when "SMBIOS Event Log" is set to Enabled)

Enter the increment value for the multiple event counter. Enter a number between 1 and 255. The default setting is **1**. (MECI is the abbreviation for Multiple Event Count Increment.)

METW (Available when "SMBIOS Event Log" is set to Enabled)

Use this feature to determine how long (in minutes) should the multiple event counter wait before generating a new event log. Enter a number between 0 and 99. The default value is **60**. (METW is the abbreviation for Multiple Event Count Time Window.)

► View SMBIOS Event Log

Use this feature to view the events in the system event log. Select this feature and press <Enter> to view the status of an event in the log. The following information is displayed: DATE / TIME / ERROR CODE / SEVERITY.

8.5 BMC

Use this menu to configure Baseboard Management Console (BMC) settings.

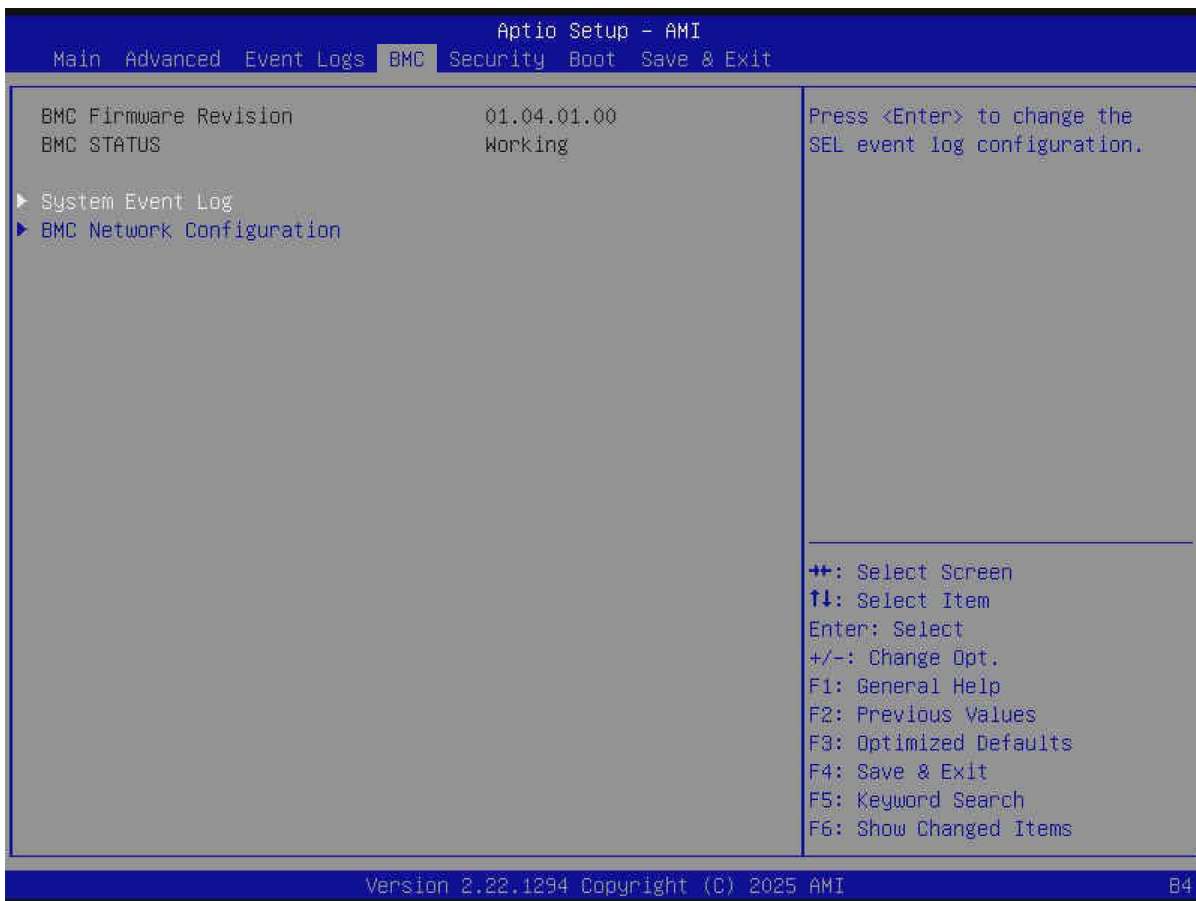

Figure 8-4. BMC Setup Page

BMC Firmware Revision

This feature indicates the BMC firmware revision used in this system.

BMC STATUS

This feature indicates the status of the BMC firmware installed in this system.

System Event Log Menu

▶ System Event Log

Note: All values changed in this submenu do not take effect until computer is restarted.

Enabling/Disabling Options

SEL Components

Select Enabled to enable all system event logging upon system boot. The options are Disabled and **Enabled**.

Erasing Settings

Erase SEL (Available when "SEL Components" is set to Enabled)

Select (Yes, On next reset) to erase all system event logs upon next system boot. Select (Yes, On every reset) to erase all system event logs upon each system reboot. Select No to keep all system event logs after each system reboot. The options are **No**, (Yes, On next reset), and (Yes, On every reset).

When SEL is Full (Available when "SEL Components" is set to Enabled)

This feature defines what the BIOS should do when the system event log is full. Select Erase Immediately to erase all events in the log when the system event log is full. The options are **Do Nothing** and Erase Immediately.

BMC Network Configuration Menu

► BMC Network Configuration

Update BMC LAN Configuration

Select Yes for the BIOS to implement all IP/MAC address changes upon next system boot. The options are **No** and Yes.

Configure IPv4 Support

BMC LAN Selection

This feature displays the type of the BMC LAN.

BMC Network Link Status:

This feature displays the status of the BMC network link for this system.

Configuration Address Source

Use this feature to select the source of the IPv4 connection. If Static is selected, note the IP address of the IPv4 connection and enter it to the system manually in the field. If DHCP is selected, the BIOS will search for a Dynamic Host Configuration Protocol (DHCP) server in the

network that is attached to and request the next available IP address for this computer. The options are Static and **DHCP**. It is available for configuration when "Update BMC LAN Configuration" is set to Yes.

Station IP Address

This feature displays the Station IP address in decimal and in dotted quad form (i.e., 172.29.176.131). It is available for configuration when "Update BMC LAN Configuration" is set to Yes and "Configuration Address Source" above is set to Static.

Subnet Mask

This feature displays the sub-network that this computer belongs to. It is available for configuration when "Update BMC LAN Configuration" is set to Yes and "Configuration Address Source" above is set to Static.

Station MAC Address

This feature displays the Station MAC address for this computer. MAC addresses are six two-digit hexadecimal numbers.

Gateway IP Address

This feature displays the IPv4 gateway IP address for this computer. This should be in decimal and in dotted quad form (i.e., 172.29.0.1). It is available for configuration when "Update BMC LAN Configuration" is set to Yes and "Configuration Address Source" above is set to Static.

Configure IPv6 Support

IPv6 Address Status

This feature displays the status of the IPv6 address.

IPv6 Support

Use this feature to enable IPv6 support. The options are **Enabled** and Disabled. It is available for configuration when "Update BMC LAN Configuration" is set to Yes.

Configuration Address Source

Use this feature to select the source of the IPv6 connection. If Static Configuration is selected, note the IP address of IPv6 connection and enter it to the system manually in the field. If the other two options are selected, the BIOS will search for a DHCP server in the network that is attached to and request the next available IP address for this computer. The options are Static Configuration, **DHCPv6 Stateless**, and DHCPv6 Stateful. It is available for configuration when "Update BMC LAN Configuration" is set to Yes.

IPv6 Address ("Static," "DHCPv6 Stateless," or "DHCPv6 Stateful," depending on the option you selected for "Configuration Address Source" above)

This feature displays the station IPv6 address. It is available for configuration when "Update BMC LAN Configuration" is set to Yes and "Configuration Address Source" above is set to Static Configuration.

Prefix Length

This feature displays the prefix length. It is available for configuration when "Update BMC LAN Configuration" is set to Yes and "Configuration Address Source" above is set to Static Configuration.

Gateway IP

This feature displays the IPv6 gateway IP address. It is available for configuration when "Update BMC LAN Configuration" is set to Yes and "Configuration Address Source" above is set to Static Configuration.

Advanced Settings

Use this feature to set the DNS server IP. The default setting allows this system to obtain the DNS server IP automatically. The options are **Auto obtain DNS server IP** and **Manually obtain DNS server IP**. It is available for configuration when "Update BMC LAN Configuration" is set to Yes and "Configuration Address Source" above is set to DHCPv6 Stateless.

Preferred DNS server IP (Available when "Advanced Settings" above is set to Manually obtain DNS server IP)

This feature displays the preferred DNS server IP. It can be configured via Redfish.

Alternative DNS server IP (Available when "Advanced Settings" above is set to Manually obtain DNS server IP)

This feature displays the alternative DNS server IP. It can be configured via Redfish.

Configure VLAN Support

VLAN Support

Use this feature to enable the virtual LAN (VLAN) support. The options are **Enabled** and **Disabled**.

VLAN ID (Available when "VLAN Support" is set to Enabled)

Use this feature to create a new VLAN ID. The valid range is 1–4094. The default setting is **1**.

8.6 Security

Use this menu to configure the following security settings for the system.

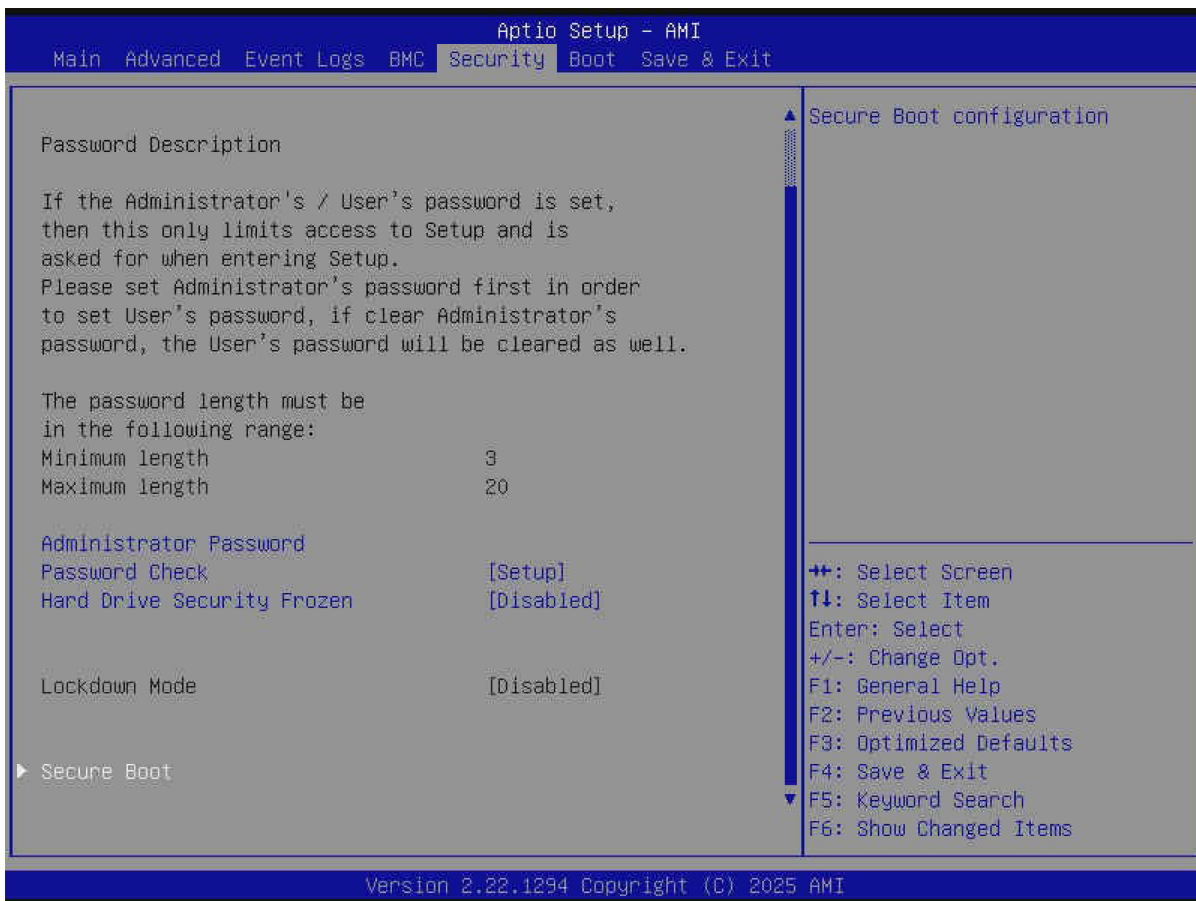

Figure 8-5. Security Setup Page

Disable Block Sid and Freeze Lock (Available when your storage devices support TCG)

Select Enabled to allow SID authentication to be performed in TCG storage devices. The options are **Disabled** and Enabled.

The following information is displayed:

- Administrator Password
- User Password
- Password Description

Administrator Password

This feature indicates if an administrator password has been installed. Use this feature to set the administrator password, which is required to enter the BIOS Setup utility. The length of the password can be between three and 20 characters long.

User Password (Available when "Administrator Password" has been set)

This feature indicates if a user password has been installed. Use this feature to set the user password which is required to enter the BIOS Setup utility. The length of the password can be between three and 20 characters long.

Password Check

Select Setup for the system to check for a password upon entering the BIOS Setup utility. Select Always for the system to check for the passwords needed at bootup and upon entering the BIOS Setup utility. The options are **Setup** and Always.

Hard Drive Security Frozen

Select Enabled to freeze the Lock Security feature for HDD to protect key data in hard drives from being altered. The options are **Disabled** and Enabled.

Lockdown Mode (Available when the DCMS key is activated)

Select Enabled to support the Lockdown Mode, which prevents the existing data or keys stored in the system from being altered or changed in an effort to preserve system integrity and security. The options are **Disabled** and Enabled.

Supermicro Security Erase Configuration Menu

► Supermicro Security Erase Configuration

Use this submenu to configure the Supermicro-proprietary Security Erase settings. When this submenu is selected, the following information is displayed. Note that the order of the following information may differ based on the storage devices being detected.

- **HDD Name:** This feature displays the model name of the storage device that is detected by the BIOS.
- **HDD Serial Number:** This feature displays the serial number of the storage device that is detected by the BIOS.
- **Security Mode:** This feature displays the security mode of the storage device that is detected by the BIOS.
- **Estimated Time:** This feature displays the estimate time needed to perform the selected Security Erase features.
- **HDD User Pwd Status:** This feature indicates if a password has been set as a storage device user password, which enables configuring Supermicro Security Erase settings on this storage device.
- **TCG Device Type:** This feature displays the TCG device type detected by the system.

- **Admin Pwd Status:** This feature indicates if a password has been set as a storage device administrator password, which enables configuring Supermicro Security Erase settings on this storage device.

Note: This submenu is available when any storage device is detected by the BIOS. For more information about this feature, refer to our website.

Security Function

Select Set Password to set a storage device user password to enable configuring the security settings on the storage device. Select Security Erase - Password to enter a storage device user password to enable erasing the password and the contents previously stored in the storage device. Select Security Erase - Without Password to use the manufacturer default password "1111111111" as the storage device user password and enable erasing the contents of the storage device by using this default password. The options are **Disabled**, Set Password, Change Password, Clear Password, Security Erase - Password, Security Erase - PSID, and Security Erase - Without Password.

Notes:

- The option of Security Erase - PSID is based on the storage device support. PSID is the abbreviation for Physical Security Identification.
- The options of Change Password and Clear Password are available when "Password" below has been set.
- The option of Set Password is NOT available when "Password" below has been set.

Password

Use this feature to set the storage device user password, which enables configuring the Supermicro Security Erase settings by using this user password.

New Password (Available when "Password" above has been set)

Use this feature to set the new user password for the storage device, which enables configuring the Supermicro Security Erase settings by using this new user password.

HDD Security Configuration Menu

► P4: (Storage device model name)

This submenu is available when the storage device is detected by the BIOS. Select this device. Press <Enter> and the following information is displayed:

- HDD Password Description:
- HDD PASSWORD CONFIGURATION:
- Security Supported:
- Security Enabled:
- Security Locked:
- Security Frozen:
- HDD User Pwd Status:
- HDD Master Pwd Status:

Set User Password (Available when "Security Frozen:" above is No)

Press <Enter> to set the HDD user password.

Secure Boot Menu

► Secure Boot

The following information is displayed:

- System Mode
- Secure Boot

Note: For detailed instructions on configuring Security Boot settings, refer to the Security Boot Configuration User's Guide at <https://www.supermicro.com/support/manuals>.

Secure Boot

Select Enabled to configure Secure Boot settings. The options are **Disabled** and Enabled.

Secure Boot Mode

Use this feature to select the desired secure boot mode for the system. The options are Standard and **Custom**.

► Enter Audit Mode

Select Ok to enter the Audit Mode workflow. It will result in erasing the Platform Key (PK) variables and resetting the system to the Setup/Audit Mode.

Note: This submenu is available when "Secure Boot Mode" is set to Custom.

▶ Enter Deployed Mode / Exit Deployed Mode

Select Ok to reset system to the User Mode or to the Deployed Mode.

Note: This submenu is available when "Secure Boot Mode" is set to Custom.

▶ Key Management

The following information is displayed:

- Vendor Keys

Note: This submenu is available when "Secure Boot Mode" is set to Custom.

Provision Factory Defaults

Select Enabled to install the default secure boot keys when the system is in the Setup Mode. Changes take effect after you save settings and reboot the system. The options are **Disabled** and Enabled.

▶ Restore Factory Keys

Select Yes to restore manufacturer default keys to ensure system security. The options are **Yes** and No. Selecting Yes will reset the system to the User Mode.

Note: This submenu is available when any secure keys have been installed.

▶ Reset To Setup Mode

This feature resets the system to the Setup Mode. The options are **Yes** and No.

Note: This submenu is available when any secure keys have been installed.

▶ Enroll Efi Image

This feature allows the Efi image to run in the secure boot mode and enroll the SHA256 Hash certificate of a PE image into the Authorized Signature Database (DB).

▶ Export Secure Boot Variables

This feature exports the NVRAM contents of secure boot variables to a storage device. The options are **Yes** and No.

Note: This submenu is available when any secure keys have been installed.

Secure Boot variable / Size / Keys / Key Source

▶ Platform Key (PK)

Use this feature to enter and configure a set of values to be used as platform firmware keys for the system. These values also indicate the sizes, key numbers, and the sources of the authorized signatures. Select Update to update the platform key.

▶ Key Exchange Keys (KEK)

Use this feature to enter and configure a set of values to be used as Key Exchange Keys for the system. These values also indicate the sizes, key numbers, and the sources of the authorized signatures. Select Update to update the Key Exchange Keys. Select Append to append the Key Exchange Keys.

▶ Authorized Signatures (db)

Use this feature to enter and configure a set of values to be used as Authorized Signatures for the system. These values also indicate the sizes, key numbers, and sources of the authorized signatures. Select Update to update the Authorized Signatures. Select Append to append the new Authorized Signatures.

▶ Forbidden Signatures (dbx)

Use this feature to enter and configure a set of values to be used as Forbidden Signatures for the system. These values also indicate sizes, key numbers, and key sources of the forbidden signatures. Select Update to update the Forbidden Signatures. Select Append to append the Forbidden Signature.

▶ Authorized TimeStamps (dbt)

Use this feature to set and save the timestamps for the Authorized Signatures, which will indicate the time when these signatures are entered into the system. These values also indicate sizes, keys, and key sources of the authorized timestamps. Select Update to update the Authorized TimeStamps. Select Append to append the Authorized TimeStamps.

► OsRecovery Signatures (dbr)

Use this feature to set and save the Authorized Signatures used for OS recovery. Select Update to update the OsRecovery Signatures. These values also indicate sizes, keys, and key sources of the OsRecovery Signatures. Select Append to append the OsRecovery Signatures.

TCG Storage Security Configuration Menu

► (Storage device model name)

Select this device. Press <Enter> and the following information is displayed:

- TCG Storage Security Password Description:
- PASSWORD CONFIGURATION:
- Security Subsystem Class:
- Security Supported:
- Security Enabled:
- Security Locked:
- Security Frozen:
- User Pwd Status:
- Admin Pwd Status:

Note: This submenu is available when the storage device is compliant with TCG specifications.

Set Admin Password

Use this feature to set the administrator password for this storage device.

Set User Password (Available when "Set Admin Password" has been set)

Use this feature to set the user password for this storage device.

Device Reset

Use this feature to reset the password configuration for this storage device.

8.7 Boot

Use this menu to configure Boot settings.

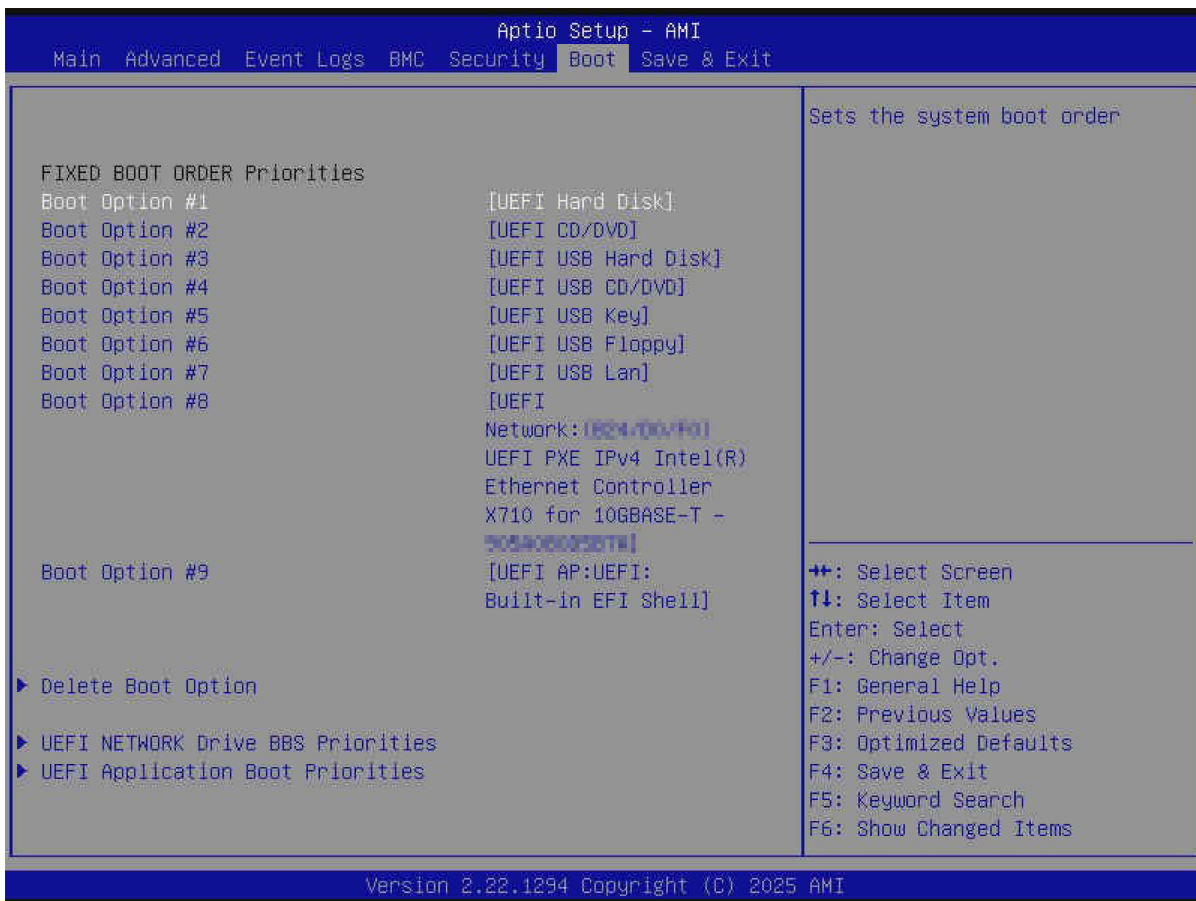

Figure 8-6. Boot Setup Page

FIXED BOOT ORDER Priorities

Use this feature to prioritize the order of a bootable device from which the system will boot. Press <Enter> on each item sequentially to select the device.

- Boot Option #1 – Boot Option #9

► Add New Boot Option

Use this feature to add a new boot option to the boot priority features for system boot.

Note: This submenu is available when any storage device is detected by the BIOS.

Add boot option

Use this feature to specify the name for the new boot option.

Path for boot option

Use this feature to enter the path for the new boot option in the format fsx:\path\filename.efi.

Boot option File Path

Use this feature to specify the file path for the new boot option.

Create

After setting the name and the file path for the boot option, press <Enter> to create the new boot option in the boot priority list.

▶ Delete Boot Option

Use this feature to select a boot device to delete from the boot priority list.

Delete Boot Option

Use this feature to remove an EFI boot option from the boot priority list.

▶ UEFI NETWORK Drive BBS Priorities

Use this feature to set the system boot order of detected devices.

▶ UEFI Application Boot Priorities

Use this feature to set the system boot order of detected devices.

▶ UEFI USB Key Drive BBS Priorities

Use this feature to set the system boot order of detected devices.

▶ UEFI Hard Disk Drive BBS Priorities

Use this feature to set the system boot order of detected devices.

8.8 Save & Exit

Select Save & Exit from the BIOS Setup screen to configure the settings below.

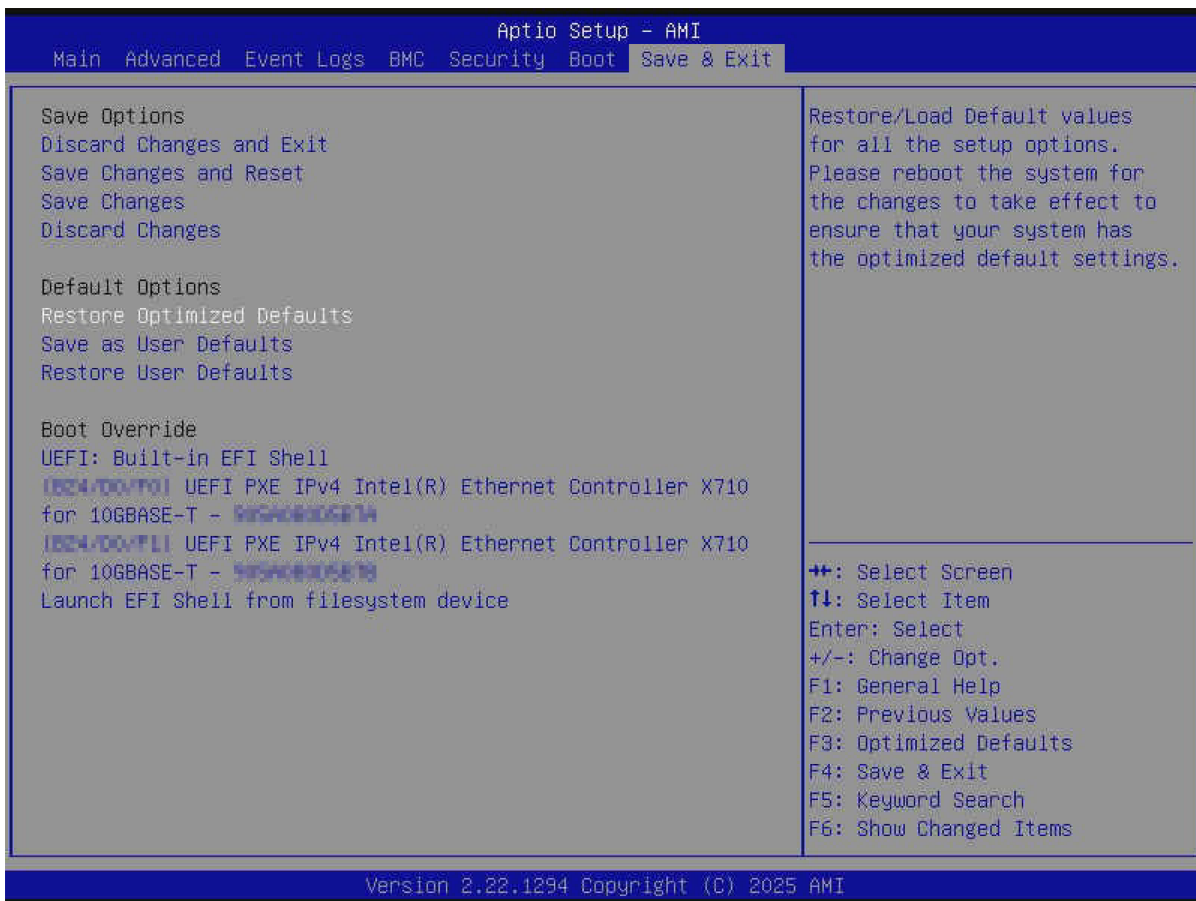

Figure 8-7. Save & Exit Setup Page

Save Options

Discard Changes and Exit

Use this feature to exit from the BIOS Setup utility without making any permanent changes to the system configuration and reboot the computer.

Save Changes and Reset

On completing the system configuration changes, use this feature to exit the BIOS Setup utility and reboot the computer for the new system configuration parameters to take effect.

Save Changes

On completing the system configuration changes, use this feature to save all changes made. This will not reset (reboot) the system.

Discard Changes

Select this feature and press <Enter> to discard all changes made and return to the BIOS Setup utility.

Default Options**Restore Optimized Defaults**

Select this feature and press <Enter> to load manufacturer optimized default settings, which are intended for maximum system performance but not for maximum stability.

Note: Reboot the system for the changes to take effect to ensure that the system has the optimized default settings.

Save as User Defaults

Select this feature and press <Enter> to save all changes as the default values specified to the BIOS Setup utility for future use.

Restore User Defaults

Select this feature and press <Enter> to retrieve user-defined default settings that have been saved previously.

Boot Override

Note: Use this section to override the Boot priorities sequence in the Boot menu, and immediately boot the system with a device specified here instead of the one specified in the boot list. This is a one-time boot override.

Launch EFI Shell from filesystem device

Use this feature to launch the EFI shell application (Shell.efi) from one of the available filesystem devices. A filesystem is a virtual, logical, or physical system for organizing, managing, and accessing the files and directories on devices such as SSDs, HDDs, or other storage devices.

Appendix A:

BIOS Codes

For information about BIOS codes for the SYS-422GA-NRT server, refer to the following content.

BIOS Error POST (Beep) Codes

During the Power-On Self-Test (POST) routines, which are performed each time the system is powered on, errors may occur.

Non-fatal errors are those which, in most cases, allow the system to continue the boot up process. The error messages normally appear on the screen.

Fatal errors are those which will not allow the system to continue the boot up process. If a fatal error occurs, you should consult with your system manufacturer for possible repairs.

These fatal errors are usually communicated through a series of audible beeps that can be heard on an external buzzer connected to JD1. The table shown below lists some common errors and their corresponding beep codes encountered by users.

BIOS Beep (POST) Codes		
Beep Code	Error Message	Description
1 beep	Refresh	Circuits have been reset (Ready to power up)
5 short, 1 long	Memory error	No memory detected in system
5 short, 2 long	Display memory read/write error	Video adapter missing or with faulty memory
1 long continuous	System OH	System overheat condition

Additional BIOS POST Codes

The AMI BIOS supplies additional checkpoint codes, which are documented online at <https://www.supermicro.com/support/manuals> ("AMI BIOS POST Codes User's Guide").

For information on AMI updates, refer to <https://www.ami.com/products>.

Appendix B:

Standardized Warning Statements for AC Systems

The following statements are industry standard warnings, provided to warn the user of situations which have the potential for bodily injury. Should you have questions or experience difficulty, contact Supermicro's Technical Support department for assistance. Only certified technicians should attempt to install or configure components.

Read this section in its entirety before installing or configuring components in the Supermicro SYS-422GA-NRT server.

These warnings may also be found on our website at the following page:

https://www.supermicro.com/about/policies/safety_information.cfm

Standard Warning Definition



Warning! This warning symbol means danger. You are in a situation that could cause bodily injury. Before you work on any equipment, be familiar with standard practices for preventing accidents.

تحذير! هذا الرمز التحذيري يعني خطر. إنك في موقف قد يتسبب في إصابة جسدية. قبل العمل على أي أجهزة يجب أن تكون على دراية بالممارسات القياسية للحيلولة دون وقوع حوادث.

警告！此警告符号代表危险，表示正处于可能遭受严重身体伤害的工作环境。在使用任何设备开始工作之前，务必熟悉防止事故发生的标准工作规范。

警告！此警告符號代表危險。您正處於可能身體可能會受損傷的工作環境中。操作任何設備之前，請熟悉標準做法以預防事故發生。

Advarsel! Dette advarselssymbol betyder fare. Du er i en situation, der kan føre til personskader. Før du arbejder på noget udstyr, skal du være bekendt med standardpraksis for at forebygge ulykker.

Waarschuwing! Dit waarschuwingssymbool betekent gevaar. U bevindt zich in een situatie die lichamelijk letsel zou kunnen veroorzaken. Voordat u aan enige apparatuur gaat werken, moet u vertrouwd zijn met standaard praktijken voor het voorkomen van ongevallen.

Varoitus! Tämä varoitussymboli tarkoittaa vaaraa. Olet tilanteessa, joka voi aiheuttaa ruumiinvammoja. Ennen kuin ryhdyt työskentelemään laitteiden parissa, tutustu onnettomuuksien ehkäisemistä koskeviin vakiintuneisiin käytäntöihin.

Attention! Ce symbole d'avertissement indique un danger. Vous vous trouvez dans une situation pouvant entraîner des blessures ou des dommages corporels. Avant de travailler sur un équipement, familiarisez-vous avec les procédures couramment utilisées pour éviter les accidents.

Warnung! Dieses Warnsymbol bedeutet Gefahr. Sie befinden sich in einer Situation, die zu Körperverletzungen führen kann. Bevor Sie an Geräten arbeiten, machen Sie sich mit den üblichen Verfahren zur Unfallverhütung vertraut.

אזהרה! סמל אזהרה זה מסמן סכנה. אתה נמצא במצב שעלול לגרום לפגיעה גופנית. לפני שתתחיל לעבוד על כל ציוד, הכר את הנהלים הסטנדרטיים למניעת תאונות.

चेतावनी! यह चेतावनी चिह्न खतरे का प्रतीक है। आप ऐसी स्थिति में हैं जिससे शारीरिक चोट लग सकती है। किसी भी उपकरण पर काम करने से पहले, दुर्घटनाओं को रोकने के लिए मानक प्रथाओं से परिचित हो लें।

警告! この警告記号は危険を意味します。人身事故につながる可能性のある状況にあります。機器で作業を行う前に、標準的な事故防止策に精通してください。

경고! 이 경고 기호는 위험이 있음을 알려 줍니다. 신체 상해를 초래할 수 있는 상황입니다. 장비에서 작업하기 전에 사고 예방을 위한 표준 수칙을 숙지하십시오.

Advarsel! Dette advarselsymbolet betyr fare. Du er i en situasjon som kan forårsake kroppsskade. Før du arbeider på noe utstyr, må du gjøre deg kjent med standardrutiner for å forhindre ulykker.

¡Advertencia! Este símbolo de advertencia significa peligro. Se encuentra en una situación que podría provocar lesiones corporales. Antes de trabajar con cualquier equipo, familiarícese con las prácticas estándar para prevenir accidentes.

Varning! Denna varningssymbol betyder fara. Du befinner dig i en situation som kan orsaka personskada. Innan du arbetar på någon utrustning måste du bekanta dig med standardrutiner för att förhindra olyckor.

Electrical Warning Definition



Warning! This warning symbol indicates high voltage may be encountered when performing a procedure. Before you work on any equipment, be aware of the hazards involved with electrical circuitry.

تحذير! يشير رمز التحذير هذا إلى احتمالية مواجهة جهد كهربائي عالٍ عند إجراء عملية ما. قبل البدء في العمل على أي أجهزة كن على دراية بالمخاطر المرتبطة بالدوائر الكهربائية.

警告！此警告符号表示作业过程中可能会遇到高电压。操作任何设备之前，请务必了解电路的危险。

警告！此警告符號表示執行程序時可能會遇到高電壓。操作任何設備之前，請瞭解與電路相關的危害。

Advarsel! Dette advarselssymbol indikerer, at der kan opstå høj spænding under udførelsen af en procedure. Før du arbejder på noget udstyr, skal du være opmærksom på de farer, der er forbundet med elektriske kredsløb.

Waarschuwing! Dit waarschuwingssymbool geeft aan dat men hoge spanning tegen kan komen bij het uitvoeren van een procedure. Voordat u aan enige apparatuur gaat werken, moet u zich bewust zijn van de gevaren van elektrische schakelssystemen.

Varoitus! Tämä varoitussymboli osoittaa, että toimenpiteen suorittamisen aikana voi esiintyä korkeaa jännitettä. Ennen kuin ryhdyt työskentelemään laitteiden parissa, ota huomioon sähköpiireihin liittyvät vaarat.

Attention! Ce symbole d'avertissement indique un risque d'exposition à une tension élevée lors de l'exécution d'une procédure. Avant de travailler sur un équipement, prenez connaissance des dangers liés aux circuits électriques.

Warnung! Dieses Warnsymbol weist darauf hin, dass bei der Durchführung eines Vorgangs Hochspannung auftreten kann. Bevor Sie an Geräten arbeiten, machen Sie sich mit den Gefahren elektrischer Schaltungen vertraut.

אזהרה! סמל אזהרה זה מציינ כי ייתכן שתיתקל במתח גבוה בעת ביצוע הליך. לפני עבודה על ציוד כלשהו, עליך להיות מודע לסכנות הכרוכות במעגלים חשמליים.

चेतावनी! यह चेतावनी चिह्न इंगित करता है कि प्रक्रिया को निष्पादित करते समय उच्च वोल्टेज का सामना करना पड़ सकता है। किसी भी उपकरण पर काम करने से पहले, विद्युत सर्किट्री से जुड़े खतरों के प्रति सचेत रहें।

警告! この警告記号は、手順を実行する際に高電圧が発生する可能性があることを示しています。機器で作業を行う前に、電気回路に関連する危険に注意してください。

경고! 이 경고 기호는 절차 수행 중 고전압에 노출될 수 있음을 알려 줍니다. 장비에서 작업하기 전에 전기 회로와 관련된 위험 요소를 충분히 인지하십시오.

Advarsel! Dette varselsymbolet indikerer at det kan oppstå høy spenning når en prosedyre utføres. Før du arbeider på utstyr, må du være oppmerksom på farene forbundet med elektriske kretser.

¡Advertencia! Este símbolo de advertencia indica que puede haber alto voltaje al realizar un procedimiento. Antes de trabajar con cualquier equipo, tenga en cuenta los peligros que conllevan los circuitos eléctricos.

Varning! Denna varningssymbol indikerar att hög spänning kan förekomma när en procedur utförs. Innan du arbetar med någon utrustning ska du vara medveten om de faror som är förknippade med elektriska kretsar.

Installation Instructions



Warning! Read the installation instructions before connecting the system to the power source.

تحذير! اقرأ تعليمات التثبيت قبل توصيل النظام بمصدر الطاقة.

警告！将此系统连接电源前，请先阅读安装说明。

警告！將系統與電源連接前，請先閱讀安裝說明。

Advarsel! Læs monteringsvejledningen, før systemet slutes til strømforsyningen.

Waarschuwing! Raadpleeg de installatie-instructies voordat u het systeem op de voedingsbron aansluit.

Varoitus! Lue asennusohjeet ennen järjestelmän liittämistä virtälähteeseen.

Attention! Avant de brancher le système sur la source d'alimentation, consulter les directives d'installation.

Warnung! Vor dem Anschließen des Systems an die Stromquelle die Installationsanweisungen lesen.

אזהרה! יש לקרוא את הוראות ההתקנה לפני חיבור המערכת למקור המתח.

चेतावनी! सिस्टम को बिजली के स्रोत से जोड़ने से पहले स्थापना निर्देश पढ़ें।

警告！システムを電源に接続する前に、設置手順書をお読み下さい。

경고! 시스템을 전원에 연결하기 전에 설치 안내를 읽어주십시오.

Advarsel! Les installasjonsinstruksjonene før du kobler systemet til strømkilden.

¡Advertencia! Lea las instrucciones de instalación antes de conectar el sistema a la red de alimentación.

Varning! Läs installationsanvisningarna innan du ansluter systemet till strömkällan.

Circuit Breaker



Warning! This product relies on the building's installation for short-circuit (overcurrent) protection. Ensure that the protective device is rated not greater than: 250 VAC, 20 A.

تحذير! يعتمد هذا المنتج على التركيبات الكهربائية في المبنى للحماية من حدوث قصر دائرة (تيار زائد). تأكد من أن تصنيف جهاز الحماية لا يتجاوز: 250 فولت تيار متردد, 20 أمبير.

警告！此产品由建筑物的供电系统提供短路(过载)保护，并确保额定电压/电流不大于 250 VAC/20 A。

警告！此產品的短路(過載電流)保護由建築物的供電系統提供，確保短路保護設備的額定電流不大於 250 VAC、20 A。

Advarsel! Dette produkt forudsætter, at bygningens elinstallation sørger for kortslutningsbeskyttelse (overstrøm). Sørg for, at beskyttelsesordeningen ikke er klassificeret til mere end: 250 VAC, 20 A.

Waarschuwing! Dit product vertrouwt op de installatie van het gebouw voor kortsluitbeveiliging (overstroombeveiliging). Zorg ervoor dat de beveiligingsvoorziening is gespecificeerd voor niet meer dan: 250 VAC, 20 A.

Varoitus! Tämä tuote on riippuvainen rakennuksen asennuksesta oikosulku- (ylivirta-) suojauksen osalta. Varmista, että suojalaitteen nimellisärvot eivät ylitä seuraavia arvoja: 250 VAC, 20 A.

Attention! Ce produit dépend de l'installation du bâtiment pour la protection contre les courts-circuits (surintensité). Assurez-vous que le dispositif de protection n'est pas supérieur à : 250 VAC, 20 A.

Warnung! Dieses Produkt ist auf den Kurzschluss- bzw. Überstromschutz der Gebäudeinstallation angewiesen. Stellen Sie sicher, dass die Schutzvorrichtung für maximal 250 VAC, 20 A ausgelegt ist.

אזהרה! מוצר זה מסתמך על תשתית החשמל של המבנה להגנה מפני קצר חשמלי (זרם יתר). ודא שדירוג התקן ההגנה אינו עולה על: 250 VAC, 20 A.

चेतावनी! यह उत्पाद शॉर्ट-सर्किट (ओवरकरंट) सुरक्षा के लिए भवन की स्थापना पर निर्भर करता है। सुनिश्चित करें कि सुरक्षात्मक उपकरण की रेटिंग निम्नलिखित से अधिक न हो: 250 VAC, 20 A.

警告! この製品は、短絡(過電流)保護装置がある建物での設置を前提としています。保護装置の定格が次の値以下であることを確認ください: 250 VAC、20 A。

경고! 이 제품은 단락(과전류) 방지에 대해서 전적으로 건물의 관련 설비에 의존합니다. 보호 장치의 정격이 다음 값을 초과하지 않도록 하십시오: 250 VAC(볼트), 20 A(암페어).

Advarsel! Dette produktet er avhengig av bygningens installasjon for kortslutningsbeskyttelse (overstrømsbeskyttelse). Sørg for at beskyttelsesanordningen ikke er klassifisert som høyere enn: 250 V vekselstrøm, 20 A.

¡Advertencia! Este producto depende de la instalación del edificio para protección contra cortocircuitos (sobrecorriente). Asegúrese de que el dispositivo de protección tenga una clasificación no mayor a: 250 VAC, 20 A.

Varning! Denna produkt är beroende av byggnadens installation för kortslutningsskydd (överströmsskydd). Se till att skyddsanordningen inte är märkt för mer än: 250 VAC, 20 A.

Power Disconnection Warning



Warning! The system must be disconnected from all sources of power and the power cord removed from the power supply module(s) before accessing the chassis interior to install or remove system components (except for hot-swappable components).

تحذير! يجب فصل النظام عن جميع مصادر الطاقة، وإزالة سلك الطاقة من وحدة/وحدات إمداد الطاقة قبل الدخول إلى الجزء الداخلي من الهيكل لتركيب أو فك مكونات النظام (باستثناء المكونات القابلة للاستبدال السريع).

警告！在打开机箱并安装或移除内部器件（热插拔器件除外）前，必须将系统完全断电，并移除电源线。

警告！在您打開機殼安裝或移除內部元件（熱插拔元件除外）前，必須將系統完全斷電，並移除電源線。

Advarsel! Systemet skal afbrydes fra alle strømkilder, og strømkablet skal fjernes fra strømforsyningsmodulerne, før der gives adgang til kabinettet for at montere eller fjerne systemkomponenter (undtagen hot-swap-komponenter).

Waarschuwing! Het systeem moet worden losgekoppeld van alle voedingen en het stroomsnoer moet uit de voedingsmodule(s) worden gehaald voorafgaand aan toegang tot de binnenkant van het chassis voor installeren of verwijderen van systeemcomponenten (behalve hot-swap componenten).

Varoitus! Järjestelmä on irrotettava kaikista virtalähteistä ja virtajohto on irrotettava virtalähdemoduulista (moduuleista) ennen kotelon sisälle pääsyä järjestelmän komponenttien asentamista tai poistamista varten (lukuun ottamatta hot-swap-komponentteja).

Attention! Le système doit être déconnecté de toutes les sources d'alimentation et le cordon d'alimentation doit être débranché du/des modules d'alimentation avant d'accéder à l'intérieur du châssis pour installer ou retirer des composants du système (à l'exception des composants remplaçables à chaud).

Warnung! Das System muss von allen Stromquellen getrennt und das Netzkabel von den Netzteilmodulen entfernt werden, bevor auf den Innenraum des Chassis zugegriffen wird, um Systemkomponenten zu installieren oder zu entfernen (ausgenommen Hot-Swap-Komponenten).

אזהרה! יש לנתק את המערכת מכל מקורות הכוח ולהסיר את כבל החשמל ממודולי/אספקת החשמל לפני הגישה לחלק הפנימי של המארז לצורך התקנה או הסרה של רכיבי המערכת (למעט רכיבים הניתנים להחלפה חמה).

चेतावनी! सिस्टम के घटकों को इंस्टॉल करने या निकालने (हॉट-स्वैप घटकों को छोड़कर) के लिए चेसिस के आंतरिक भाग तक पहुँचने से पहले, सिस्टम को बिजली के सभी स्रोतों से डिस्कनेक्ट किया जाना चाहिए और बिजली की आपूर्ति मॉड्यूल से पावर कॉर्ड को निकाल दिया जाना चाहिए।

警告! システムコンポーネント(ホットスワップコンポーネントを除く)の取り付けまたは取り外しを行うために、シャーシ内部にアクセスするには、システムの電源はすべてのソースから切断され、電源コードは電源モジュールから取り外す必要があります。

경고! (핫스왑 구성품을 제외하고) 시스템에 부품들을 장착하거나 제거하기 위해서는 새시 내부에 접근하기 전에 반드시 전원 공급장치로부터 연결되어있는 모든 전원과 전기코드를 분리해주어야 합니다.

Advarsel! Systemet må kobles fra alle strømkilder, og strømledningen må fjernes fra strømforsyningsmodulen (e) før man går inn i kabinettet for å installere eller fjerne systemkomponenter (unntatt komponenter som kan byttes ut under drift).

¡Advertencia! El sistema debe estar desconectado de todas las fuentes de energía y el cable de alimentación debe retirarse de los módulos de fuente de alimentación antes de acceder al interior del chasis para instalar o quitar componentes del sistema (excepto los componentes reemplazables en caliente).

Varning! Systemet måste vara frångopplat från alla strömkällor och strömsladden måste vara borttagen från strömförsörjningsmodulerna innan du öppnar chassit för att installera eller ta bort systemkomponenter (med undantag för hot-swap-komponenter).

Equipment Installation



Warning! Only authorized personnel and qualified service persons should be allowed to install, replace, or service this equipment.

تحذير! لا يُسمح إلا للعاملين المعتمدين وفنيي الخدمة المؤهلين بتركيب هذا الجهاز أو استبداله أو صيانته.

警告！仅限经过授权培训且拥有相关资质的人员才能进行此设备的安装、更换和维修。

警告！只有經過受訓且具資格人員才可安裝、更換與維修此設備。

Advarsel! Dette udstyr må kun installeres, udskiftes eller serviceres af autoriseret personale og kvalificerede servicemedarbejdere.

Waarschuwing! Alleen geautoriseerd personeel en gekwalificeerd onderhoudspersoneel mag deze apparatuur installeren, vervangen of onderhouden.

Varoitus! Vain valtuutetut henkilöt ja pätevät huoltoteknikot saavat asentaa, vaihtaa tai huoltaa tätä laitetta.

Attention! Seul le personnel autorisé et le personnel de maintenance qualifié doivent être autorisés à installer, remplacer ou entretenir cet équipement.

Warnung! Nur autorisiertes Personal und qualifizierte Servicetechniker dürfen dieses Gerät installieren, austauschen oder warten.

אזהרה! רק אנשי צוות מורשים ואנשי שירות מוסמכים רשאים להתקין, להחליף או לטפל בציוד זה.

चेतावनी! केवल अधिकृत कर्मियों और योग्य सेवा व्यक्तियों को ही इस उपकरण को स्थापित करने, बदलने या सेवा देने की अनुमति दी जानी चाहिए।

警告！トレーニングを受け認定された人だけがこの機器の設置、交換、またはサービスを許可されています。

경고! 승인된 직원과 자격을 갖춘 서비스 담당자만이 이 장비를 설치, 교체 또는 서비스할 수 있습니다.

Advarsel! Kun autorisert personell og kvalifiserte servicefolk skal ha tillatelse til å installere, bytte ut eller utføre service på dette utstyret.

¡Advertencia! Sólo el personal autorizado y el personal de servicio calificado pueden instalar, reemplazar o dar servicio a este equipo.

Varning! Endast auktoriserad personal och kvalificerade servicetekniker får installera, byta ut eller utföra service på denna utrustning.

Rack Stability Hazard



Warning! Stability hazard. The rack may tip over causing serious personal injury. Before extending the rack to the installation position, read the installation instructions. Do not put any load on the slide-rail mounted equipment in the installation position. Do not leave the slide-rail mounted equipment in the installation position.

تحذير! خطر عدم الاستقرار. قد ينقلب الحامل، مما قد يتسبب في إصابات شخصية خطيرة. قبل تمديد الحامل إلى موضع التركيب اقرأ إرشادات التركيب. لا تضع أي حمولة على الأجهزة المركبة على حوامل منزلقة في وضع التركيب. لا تترك الأجهزة المركبة على حوامل منزلقة في وضع التركيب.

警告！稳定性危险。机架可能会翻倒，造成严重的人身伤害。在将机架延伸到安装位置之前，请阅读安装说明。请勿在安装位置对滑轨安装的设备施加任何负载。请勿将滑轨安装的设备留在安装位置。

警告！穩定性危險。機架可能會翻倒，造成嚴重的人身傷害。將機架延伸至安裝位置前，請先閱讀安裝說明。請勿在安裝位置的滑軌安裝設備上放置任何負載。請勿將滑軌安裝設備留在安裝位置。

Advarsel! Stabilitetsfare. Udstyrsskabet kan vælte, hvilket kan føre til alvorlige personskader. Læs monteringsvejledningen, før udstyrsskabet trækkes ud til monteringsstedet. Anbring ikke nogen belastning på udstyr monteret på skinner, når det er på monteringsstedet. Efterlad ikke udstyr monteret på skinner på monteringsstedet.

Waarschuwing! Gevaar voor instabiliteit. Het rack kan kantelen en ernstig persoonlijk letsel veroorzaken. Lees de installatie-instructies voordat u het rack uitschuift naar de installatiepositie. Plaats geen last op de op de glijrail gemonteerde apparatuur in de installatiepositie. Laat de op de glijrail gemonteerde apparatuur niet in de installatiepositie staan.

Varoitus! Vakausvaara. Teline voi kaatua ja aiheuttaa vakavia henkilövahinkoja. Ennen telineen asettamista asennusasentoon, lue asennusohjeet. Älä aseta mitään kuormitusta liukukiskoon asennettuihin laitteisiin asennusasennossa. Älä jätä liukukiskoon asennettuja laitteita asennusasentoon.

Attention! Danger d'instabilité. Le rack peut basculer et provoquer des blessures corporelles graves. Avant d'étendre le rack en position d'installation, lire les instructions d'installation. Ne pas charger l'équipement monté sur rail de glissière en position d'installation. Ne pas laisser l'équipement monté sur rail de glissière en position d'installation.

Warnung! Gefahr der Instabilität. Das Rack kann umkippen und schwere Verletzungen verursachen. Lesen Sie vor dem Ausziehen des Racks in die Installationsposition die Installationsanweisungen. Belasten Sie in der Installationsposition keine auf Gleitschienen montierten Geräte. Lassen Sie auf Gleitschienen montierte Geräte nicht unbeaufsichtigt in der Installationsposition.

אזהרה! סכנת יציבות. הארון עלול להתהפך ולגרום לפציעה גופנית חמורה. לפני הארכת הארון למצב התקנה, יש לקרוא את הוראות ההתקנה. אין להניח עומס כלשהו על הציוד המותקן על מסילות ההחלקה כשהוא במצב התקנה. אין להשאיר את הציוד המותקן על מסילות ההחלקה במצב התקנה.

चेतावनी! स्थिरता का खतरा। रैक पलट सकता है जिससे गंभीर व्यक्तिगत चोट लग सकती है। रैक को इंस्टालेशन स्थिति तक बढ़ाने से पहले, स्थापना निर्देश पढ़ें। स्थापना स्थिति में स्लाइड-रेल पर लगे उपकरणों पर कोई भार न डालें। स्लाइड-रेल पर लगे उपकरणों को स्थापना स्थिति में न छोड़ें।

警告！安定性に危険があります。ラックが転倒して、重大な人身事故を引き起こす可能性があります。ラックを設置位置まで伸ばす前に、設置手順をお読みください。設置位置にあるスライドレールに取り付けられた機器に負荷をかけないでください。スライドレールに取り付けられた機器を設置位置に放置しないでください。

경고! 안정성 위험. 랙이 넘어져 심각한 개인 부상을 입을 수 있습니다. 랙을 설치 위치까지 확장하기 전에 설치 지침을 읽으십시오. 설치 위치에서 슬라이드 레일 장착 장비에 하중을 가하지 마십시오. 슬라이드 레일 장착 장비를 설치 위치에 두지 마십시오.

Advarsel! Stabilitetsfare. Stativet kan velte og forårsake alvorlig personskade. Les installasjonsanvisningen før du forlenger stativet till installasjonsposisjonen. Ikke belast utstyret som er montert på glideskinnen i installasjonsposisjon. Ikke la utstyret som er montert på glideskinnen stå i installasjonsposisjon.

¡Advertencia! Peligro de inestabilidad. El rack podría volcarse y causar lesiones personales graves. Antes de extender el rack a la posición de instalación, lea las instrucciones de instalación. No coloque ninguna carga sobre el equipo montado sobre rieles deslizantes en la posición de instalación. No deje el equipo montado sobre rieles deslizantes en la posición de instalación.

Varning! Stabilitetsrisk. Racket kan välta och orsaka allvarliga personskador. Läs monteringsanvisningarna innan du skjuter ut racket till monteringspositionen. Belasta ej utrustning som är monterad på glidskena i installationsläget. Lämna ej utrustning som är monterad på glidskena i monteringsläget.

Rack-Mounted Equipment Warning



Warning! Rack-mounted equipment should not be used as a shelf or work space.

تحذير! لا ينبغي استخدام المعدات المثبتة على حوامل كرف أو مساحة عمل.

警告！机架式设备不应用作货架或工作空间。

警告！不得將機架式設備當作置物架或工作空間使用。

Advarsel! Udstyr, der er monteret i udstyrsskabe, må ikke bruges som hylder eller arbejdsflader.

Waarschuwing! In rack gemonteerde apparatuur moet niet worden gebruikt als plank of werkruimte.

Varoitus! Telineasennettavia laitteita ei saa käyttää hyllynä tai työtasoina.

Attention! Un équipement installé en rack ne doit pas être utilisé comme une étagère ou un espace de travail.

Warnung! In Racks montierte Geräte dürfen nicht als Ablagefläche oder Arbeitsfläche verwendet werden.

אזהרה! אין להשתמש בצידוד המותקן במסד (Rack) כמדף או כמשטח עבודה.

चेतावनी! रैक-माउंटेड उपकरण का उपयोग शेल्फ या कार्यक्षेत्र के रूप में नहीं किया जाना चाहिए।

警告！ラックマウント機器を棚や作業スペースとして使用しないでください。

경고 ! 랙 장착 장비를 선반 또는 작업대처럼 사용하지 마십시오.

Advarsel! Rackmontert utstyr skal ikke brukes som hylle eller arbeidsområde.

¡Advertencia! Los equipos montados en rack no deben utilizarse como estante o espacio de trabajo.

Varning! Rackmonterad utrustning ska inte användas som hylla eller arbetsyta.

Restricted Access Location



Warning! This unit is intended for installation in restricted access areas. A restricted access area can be accessed only by an instructed person or a skilled person.

تحذير! هذه الوحدة مخصصة للتركيب في المناطق الممنوع الدخول إليها. يقتصر الدخول إلى منطقة منع الدخول إلا للأشخاص المدربين أو المهرة.

警告！此装置应安装在限制进出的场所，而此类场所仅限经过相关训练或技术熟练的人员进出。

警告！此部件應安裝在限制進出區域。只有受過指導的人員或專業人員才可進出限制進出區域。

Advarsel! Denne enhed er beregnet til montering i områder med begrænset adgang. Et område med begrænset adgang må kun tilgås af en instrueret person eller en fagkyndig person.

Waarschuwing! Deze eenheid is bedoeld voor installatie in gebieden met beperkte toegang. Er kan alleen toegang worden verkregen tot een gebied met beperkte toegang door een geïnstrueerde persoon of een ervaren persoon.

Varoitus! Tämä laite on tarkoitettu asennettavaksi rajoitetun pääsyn alueille. Rajoitetun pääsyn alueelle pääsee vain koulutettu tai ammattitaitoinen henkilö.

Attention! Cet appareil est destiné à être installé dans des zones à accès restreint. Une zone à accès restreint n'est accessible qu'à une personne formée ou qualifiée.

Warnung! Diese Einheit ist zur Installation in Bereichen mit beschränktem Zutritt vorgesehen. Ein Bereich mit beschränktem Zutritt darf nur von unterwiesenen oder fachkundigen Personen betreten werden.

אזהרה! יחידה זו מיועדת להתקנה באזורים עם גישה מוגבלת. ניתן לגשת לאזור עם גישה מוגבלת רק על ידי אדם שהוכשר לכך או אדם מיומן.

चेतावनी! यह इकाई प्रतिबंधित पहुँच वाले क्षेत्रों में स्थापना के लिए ही है। प्रतिबंधित पहुँच वाले क्षेत्र में केवल एक निर्देशित व्यक्ति या कुशल व्यक्ति द्वारा ही पहुँचा जा सकता है।

警告！このユニットはアクセス制限区域に設置することを想定しています。アクセス制限区域は、トレーニングを受けた人または熟練者だけが出入り可能です。

경고! 본 장치는 접근이 제한된 구역에 설치하도록 되어있습니다. 교육을 받은 사람 또는 숙련된 사람만 접근 제한 구역에 들어갈 수 있습니다.

Advarsel! Denne enheten er beregnet for installasjon i områder med begrenset tilgang. Et område med begrenset tilgang kan kun nås av en person som har fått instruksjoner eller en fagperson.

¡Advertencia! Esta unidad está diseñada para su instalación en áreas de acceso restringido. A un área de acceso restringido solo puede acceder una persona instruida o una persona capacitada.

Varning! Denna enhet är avsedd för installation i områden med begränsad åtkomst. Ett område med begränsad åtkomst får endast beträdas av en instruerad eller kvalificerad person.

Battery Handling



Warning! There is risk of explosion if the battery is replaced by an incorrect type. Replace the battery only with the same or equivalent type recommended by the manufacturer. Dispose of used batteries according to the manufacturer's instructions.

تحذير! يوجد خطر حدوث انفجار إذا تم استبدال البطارية بنوع غير صحيح. استبدل البطارية بنفس النوع أو نوع مكافئ موصى به من قبل الشركة المصنعة فقط. يجب التخلص من البطاريات المستخدمة وفقاً لإرشادات الجهة المصنعة.

警告！如果更换的电池类型不正确，有爆炸危险。更换电池时，请使用制造商推荐的相同或同等型号的电池。请按制造商的说明处理废旧电池。

警告！如果更換的電池類型不正確，有爆炸危險。請使用製造商建議之相同或功能相當的電池更換原有電池。請按照製造商的說明指示處理廢棄舊電池。

Advarsel! Der er risiko for eksplosion, hvis batteriet skiftes med et batteri af den forkerte type. Batteriet må kun skiftes med et batteri af samme eller tilsvarende type, der anbefales af producenten. Opbrugte batterier skal bortskaffes i henhold til vejledningerne fra producenten.

Waarschuwing! Er bestaat een explosiegevaar als de batterij wordt vervangen door een onjuist type. Vervang de batterij alleen door hetzelfde type of een soortgelijk type aanbevolen door de fabrikant. Verwijder gebruikte batterijen overeenkomstig de instructies van de fabrikant.

Varoitus! Väärän tyypisen akun käyttö voi aiheuttaa räjähdysvaaran. Vaihda akku vain valmistajan suosittelemaan samaan tai vastaavaan tyypiseen akkuun. Hävitä käytetyt paristot valmistajan ohjeiden mukaisesti.

Attention! Il y a un risque d'explosion si la batterie est remplacée par une d'un type incorrect. Remplacez la batterie uniquement par une d'un type identique ou équivalent recommandé par le fabricant. Éliminez les batteries usagées conformément aux instructions du fabricant.

Warnung! Es besteht Explosionsgefahr, wenn die Batterie durch einen falschen Typ ersetzt wird. Ersetzen Sie die Batterie ausschließlich durch denselben oder einen vom Hersteller empfohlenen gleichwertigen Typ. Entsorgen Sie gebrauchte Batterien gemäß den Anweisungen des Herstellers.

אזהרה! קיימת סכנת פיצוץ אם הסוללה תוחלף בסוללה מסוג שגוי. החלף את הסוללה רק בסוללה מאותו סוג או בסוללה מקבילה המומלצת על ידי היצרן. השלך סוללות משומשות בהתאם להוראות היצרן.

चेतावनी! यदि बैटरी को गलत प्रकार से बदला जाता है तो विस्फोट का जोखिम है। बैटरी को केवल निर्माता द्वारा अनुशंसित समान या समकक्ष प्रकार से ही बदलें। इस्तेमाल की गई बैटरियों का निपटान निर्माता के निर्देशों के अनुसार करें।

警告! 電池を間違ったタイプに交換すると爆発する危険があります。交換する電池はメーカーが推奨するタイプ、または同等のものを使用してください。使用済み電池は、メーカーの指示に従って廃棄してください。

경고! 배터리를 잘못된 종류로 교체하면 폭발의 위험이 있습니다. 기존 배터리와 동일하거나 제조사에서 권장하는 동등한 종류의 배터리로만 교체해야 합니다. 제조사의 안내에 따라 사용된 배터리를 처리하여 주십시오.

Advarsel! Det er fare for eksplosjon hvis batteriet byttes ut med et av feil type. Batterier skal kun byttes ut med et av lik eller tilsvarende type, som anbefalt av produsenten. Kast brukte batterier i henhold til produsentens instruksjoner.

¡Advertencia! Existe riesgo de explosión si se sustituye la batería por una de tipo incorrecto. Reemplace la batería únicamente con el mismo tipo o uno equivalente recomendado por el fabricante. Deseche las baterías usadas de acuerdo con las instrucciones del fabricante.

Varning! Det finns risk för explosion om batteriet byts ut mot en felaktig typ. Byt endast ut batteriet mot ett batteri av samma eller likvärdig typ som rekommenderas av tillverkaren. Kassera förbrukade batterier i enlighet med tillverkarens anvisningar.

Redundant Power Supplies



Warning! This unit might have more than one power supply connection. All connections must be removed to de-energize the unit.

تحذير! قد تحتوي هذه الوحدة على أكثر من وصلة لإمداد الطاقة. يجب فصل جميع التوصيلات لفصل الطاقة عن الوحدة.

警告！本设备可能有多个电源连接。必须切断所有连接，才能使设备断电。

警告！此裝置連接的電源可能不只一個。必須切斷所有電源才能停止對該裝置的供電。

Advarsel! Denne enhed kan have mere end én strømforsyningsforbindelse. Alle forbindelser skal fjernes for at deaktivere spændingen.

Waarschuwing! Deze eenheid kan meer dan één stroomtoevoeraansluiting bevatten. Alle aansluitingen dienen verwijderd te worden om het apparaat stroomloos te maken.

Varoitus! Laitteessa voi olla useampi kuin yksi virtalähteen liitäntä. Laitteen virta on katkaistava irrottamalla kaikki liitännät.

Attention! Cette unité peut avoir plus d'une connexion d'alimentation. Pour supprimer toute tension et tout courant électrique de l'unité, toutes les connexions d'alimentation doivent être débranchées.

Warnung! Diese Einheit kann über mehr als eine Stromversorgungsanschluss verfügen. Um sicherzustellen, dass die Einheit spannungsfrei ist, müssen alle Verbindungen entfernt werden.

אזהרה! יחידה זו עשויה לכלול יותר מחיבור אחד לספק כוח. יש לנתק את כל החיבורים כדי להפסיק את הזנת המתח ליחידה.

चेतावनी! इस इकाई में एक से अधिक पावर सप्लाय कनेक्शन हो सकते हैं। इकाई को ऊर्जा-मुक्त (डी-एनर्जाइज) करने के लिए सभी कनेक्शन हटा दिए जाने चाहिए।

警告！このユニットは複数の電源装置が接続されている場合があります。ユニットの電源を切るためには、すべての接続を取り外さなければなりません。

경고! 이 장치에는 한 개 이상의 전원 공급 단자가 연결되어 있을 수 있습니다. 이 장치에 전원을 차단하기 위해서는 모든 연결 단자를 제거해야만 합니다.

Advarsel! Denne enheten kan ha mer enn én strømforsyningstilkobling. Alle tilkoblinger må fjernes for å gjøre enheten strømløs.

¡Advertencia! Puede que esta unidad tenga más de una conexión para fuentes de alimentación. Para cortar por completo el suministro de energía, deben desconectarse todas las conexiones.

Varning! Denna enhet kan ha mer än en strömförsörjningsanslutning. Alla anslutningar måste tas bort för att enheten ska bli strömlös.

Backplane Voltage



Warning! Hazardous voltage or energy is present on the backplane when the system is operating. Use caution when servicing. Read the instructions before servicing.

تحذير! يوجد جهد أو طاقة خطيرة على اللوحة الخلفية أثناء تشغيل النظام. توخ الحذر عند إجراء الصيانة. اقرأ التعليمات قبل إجراء الصيانة.

警告！当系统运行时，背板上存在危险电压或能量，进行维修时务必小心。维修前请阅读使用说明。

警告！系統運作時，背板上存在危險電壓或能量。維修時請小心。維修前請閱讀說明書。

Advarsel! Når systemet er i drift, er farlig spænding eller energi til stede på bagpladen. Vær forsigtig ved servicering. Læs instruktionerne før service.

Waarschuwing! Gevaarlijke spanning of energie is aanwezig op de achterzijde wanneer het systeem in bedrijf is. Wees voorzichtig bij service. Lees de instructies voorafgaand aan service.

Varoitus! Järjestelmän ollessa käynnissä takapaneelissa on vaarallista jännitettä tai energiaa. Ole varovainen huoltotöiden aikana. Lue ohjeet ennen huoltoa.

Attention! Une tension ou de l'énergie dangereuse est présente sur le panneau arrière lorsque le système est en fonctionnement. Soyez prudent lors de l'entretien. Lisez les instructions avant d'effectuer un entretien.

Warnung! Bei eingeschaltetem System liegt an der Backplane gefährliche Spannung oder Energie an. Seien Sie bei Wartungsarbeiten vorsichtig. Lesen Sie vor der Wartung die Anweisungen.

אזהרה! מתח או אנרגיה מסוכנים קיימים בלוח האחורי כאשר המערכת פועלת. יש לנקוט בזהירות בעת ביצוע תחזוקה. קרא את ההוראות לפני ביצוע תחזוקה.

चेतावनी! जब सिस्टम चालू होता है, तो बैकप्लेन पर खतरनाक वोल्टेज या ऊर्जा मौजूद होती है। सर्विसिंग करते समय सावधानी बरतें। सर्विसिंग से पहले निर्देश पढ़ें।

警告! システムの稼働中は、危険な電圧または電流がバックプレーン上にかかっています。修理を行う際には注意してください。修理を行う前に取扱説明書をお読みください。

경고! 시스템이 동작 중일 때 후면판(Backplane)에는 위험한 전압이나 에너지가 발생합니다. 서비스 작업 시 주의하십시오. 서비스 작업 전에 지침을 읽으십시오.

Advarsel! Det er farlig spenning eller energi på bakplaten når systemet er i drift. Vær forsiktig ved service. Les instruksjonene før service.

¡Advertencia! Hay voltaje o energía peligrosos presentes en la placa posterior cuando el sistema está en funcionamiento. Tenga cuidado al realizar el mantenimiento. Lea las instrucciones antes de realizar el mantenimiento.

Varning! Farlig spänning eller energi finns på backplane när systemet är i drift. Var försiktig vid service. Läs instruktionerna före service.

Comply with Local and National Electrical Codes



Warning! Installation of the equipment must comply with local and national electrical codes.

تحذير! يجب أن يتوافق تركيب الأجهزة مع لوائح الكهرباء المحلية والوطنية.

警告！设备安装必须符合本地与本国电气法规。

警告！設備安裝必須符合本地與本國電氣法規。

Advarsel! Alle lokale og nationale el-regler skal overholdes under montering af udstyret.

Waarschuwing! Bij installatie van de apparatuur moet worden voldaan aan de lokale en nationale elektriciteitsvoorschriften.

Varoitus! Laitteiden asennus on suoritettava paikallisten ja kansallisten sähkömääräysten mukaisesti.

Attention! L'équipement doit être installé conformément aux normes électriques nationales et locales.

Warnung! Die Installation des Geräts muss den lokalen und nationalen elektrotechnischen Vorschriften entsprechen.

אזהרה! התקנת הציוד חייבת להתבצע בהתאם לתקני החשמל המקומיים והארציים.

चेतावनी! उपकरण की इंस्टालेशन स्थानीय और राष्ट्रीय विद्युत कोड के अनुरूप होनी चाहिए।

警告！機器の取り付けはその地域および国の電気規定に準拠する必要があります。

경고! 현 지역 및 국가의 전기 규정에 따라 장비를 설치해야 합니다.

Advarsel! Installasjon av utstyret må være i samsvar med lokale og nasjonale elektriske forskrifter.

¡Advertencia! La instalacion del equipo debe cumplir con las normas de electricidad locales y nacionales.

Varning! Installation av utrustningen måste följa lokala och nationella elektriska föreskrifter.

Fan Warning



Warning! Hazardous moving parts. Keep away from moving fan blades. The fans might still be turning when you remove the fan assembly from the chassis. Keep fingers, screwdrivers, and other objects away from the openings in the fan assembly's housing.



تحذير! تجنب خطر الأجزاء المتحركة. ابتعد عن شفرات المروحة المتحركة. قد تستمر المراوح في الدوران بعد فك مجموعة المراوح من الهيكل. أبق أصابعك ومفكات البراغي والأغراض الأخرى بعيدة عن الفتحات الموجودة في مبيت مروحة التبريد.

警告！危险的活动零部件。请务必与转动的风扇叶片保持距离。从机箱移除风扇装置时，风扇可能仍在转动。小心不要将手指、螺丝起子和其他物品太靠近风扇外壳开口。

警告！危險的可移動性零件。請務必與轉動的風扇葉片保持距離。當您從機架移除風扇裝置，風扇可能仍在轉動。小心不要將手指、螺絲起子和其他物品太靠近風扇。

Advarsel! Farlige bevægelige dele. Hold dig væk fra ventilatorblade i bevægelse. Ventilatorerne kan stadig køre, når du tager ventilatorsamlingen af kabinettet. Hold fingre, skruetrækkere og andre genstande væk fra åbningerne i ventilatorkabinettet.

Waarschuwing! Gevaarlijke bewegende onderdelen. Houd voldoende afstand tot de bewegende ventilatorbladen. Het is mogelijk dat de ventilator nog draait tijdens het verwijderen van het ventilatorsamenstel uit het chassis. Houd uw vingers, schroevendraaiers en eventuele andere voorwerpen uit de buurt van de openingen in de ventilatorbehuizing.

Varoitus! Vaaralliset liikkuvat osat. Pysy kaukana liikkuvista tuulettimen siivistä. Tuulettimet saattavat edelleen pyöriä, kun irrotat tuulettimen kokoonpanon kotelosta. Pidä sormet, ruuvimeisselit ja muut esineet poissa tuulettimen kotelon aukkojen läheltä.

Attention! Pieces mobiles dangereuses. Se tenir à l'écart des lames du ventilateur Il est possible que les ventilateurs soient toujours en rotation lorsque vous retirerez le bloc ventilateur du châssis. Prenez garde à ce que doigts, tournevis et autres objets soient éloignés du logement du bloc ventilateur.

Warnung! Gefährliche bewegliche Teile. Halten Sie Abstand von rotierenden Lüfterblättern. Die Lüfter können sich noch drehen, wenn Sie die Lüfterbaugruppe aus dem Chassis entfernen. Halten Sie Finger, Schraubendreher und andere Gegenstände von den Öffnungen des Lüftergehäuses fern.

אזהרה! חלקים נעים מסוכנים. יש להתרחק מלהבי מאוורר נעים. המאווררים עשויים להמשיך להסתובב בעת הסרת מכלול המאוורר מהמארז. יש להרחיק אצבעות, מברגים וחפצים אחרים מהפתחים שבבית מכלול המאוורר.

चेतावनी! खतरनाक चलते हुए भाग। चलते हुए पंखे के ब्लेड से दूर रहें। जब आप चैसिस से पंखे की असेंबली निकालते हैं, तब भी पंखे घूम रहे हो सकते हैं। उंगलियों, स्कूट्राइवर और अन्य वस्तुओं को पंखे की असेंबली के हाउसिंग के छिद्रों से दूर रखें।

警告！回転部品に注意。運転中は回転部（羽根）に触れないでください。シャーンからファンアセンブリを取り外す際、ファンがまだ回転している可能性があります。ファンアセンブリの開口部に、指、ドライバー、およびその他のものを近づけないで下さい。

경고! 움직이는 위험한 부품. 회전하는 송풍 날개에 접근하지 마세요. 새시로부터 팬 조립품을 제거할 때 팬은 여전히 회전하고 있을 수 있습니다. 팬 조립품 외관의 열려있는 부분들로부터 손가락 및 스크류드라이버, 다른 물체들이 가까이 하지 않도록 배치해 주십시오.

Advarsel! Farlige bevegelige deler. Hold deg unna vifteblader i fart. Viftene kan fortsatt gå rundt når du fjerner vifteenheten fra kabinettet. Hold fingre, skrutrekkere og andre gjenstander unna åpningene i viftehuset.

¡Advertencia! Riesgo de piezas móviles. Mantener alejado de las aspas del ventilador. Los ventiladores podran dar vuelta cuando usted quite el montaje del ventilador del chasis. Mantenga los dedos, los destornilladores y todos los objetos lejos de las aberturas del ventilador.

Varning! Farliga rörliga delar. Håll dig borta från rörliga fläktblad. Fläktarna kan fortfarande snurra när du tar bort fläktenheten från chassit. Håll fingrar, skruvmejslar och andra föremål borta från öppningarna i fläktenhetens hölje.

Connection to Earth



Warning! Equipment shall be connected to an Earth mains socket-outlet.

تحذير! يجب توصيل الأجهزة بمقبس كهربائي أرضي.

警告！设备应连接到接地电源插座。

警告！應將設備連接至接地電源插座。

Advarsel! Dette udstyr skal sluttes til en jordforbundet stikkontakt.

Waarschuwing! De apparatuur moet worden aangesloten op een geaard netstopcontact.

Varoitus! Laitteet on kytkettävä maadoitettuun pistorasiaan.

Attention! L'équipement doit être connecté à une prise de courant avec mise à la terre.

Warnung! Das Gerät muss an eine geerdete Netzsteckdose angeschlossen werden.

אזהרה! יש לחבר את הציוד לשקע חשמל עם הארקה.

चेतावनी! उपकरण को एक अर्थ मेन्स सॉकेट-आउटलेट से जोड़ा जाना चाहिए।

警告！機器は、接地主電源コンセントに接続するものとします。

경고! 장비는 접지된 전원 콘센트에 연결해야 합니다.

Advarsel! Utstyret skal kobles til en jordet stikkontakt.

¡Advertencia! El equipo deberá conectarse a una toma de corriente con conexión a tierra.

Varning! Utrustningen ska vara ansluten till ett jordat eluttag.

Power Cable and AC Adapter



Warning! When installing the product, use the provided or designated connection cables, power cables and AC adaptors. Using any other cables and adaptors could cause a malfunction or a fire. Electrical Appliance and Material Safety Law prohibits the use of UL or CSA -certified cables (that have UL/CSA shown on the cord) for any other electrical devices than products designated by Supermicro only.

تحذير! عند تركيب المنتج استخدم كابلات التوصيل والطاقة ومحولات التيار المتردد المرفقة أو المخصصة. قد يؤدي استخدام أي كابلات ومحولات أخرى إلى حدوث عطل أو نشوب حريق. يحظر قانون سلامة الأجهزة والمواد الكهربائية استخدام كابلات UL أو المعتمدة من CSA (التي عليها علامة UL/CSA) لأي أجهزة كهربائية أخرى غير المنتجات التي تحددها شركة Supermicro فقط.

警告！安装时，请使用设备本身提供或指定的连接线、电源线和交流适配器。使用任何其他电缆线材或适配器都可能导致故障或火灾。除美超微(Supermicro)指定的产品外，《电气用品和材料安全法》禁止将UL或CSA认证的电缆(线材上标有UL/CSA)用于任何其他电气设备。

警告！安裝此產品時，請使用本身隨附或指定的連接線、電源線和電源適配器，包含遵照當地法規和安全要求的合規的電源線尺寸和插頭。使用其它線材或適配器可能會引起故障或火災。除了美超微(Supermicro) 所指定的產品，《電氣用品及材料安全法》規定禁止使用未經UL或CSA認證的線材。(線材上標有UL/CSA符號) 。

Advarsel! Når du monterer produktet, skal du bruge de medfølgende eller udpegede forbindelseskabler, strømkabler og vekselstrømsadaptore (AC). Brug af andre kabler og adaptore kan føre til fejl eller brand. Loven om sikkerhed for elektriske apparater og materialer forbyder brugen af UL- eller CSA-certificerede kabler (med UL/CSA angivet på ledningen) til andre elektriske apparater end dem, der udelukkende er godkendt af Supermicro.

Waarschuwing! Bij het installeren van het product moet u de geleverde of aangewezen aansluitkabels, voedingskabels en AC-adapters gebruiken. Het gebruik van enige andere kabels en adapters kan een storing of brand veroorzaken. Wetgeving voor Elektrische apparatuur en Materiaalveiligheid verbied het gebruik van UL- of CSA -gecertificeerde kabels (met UL/CSA in de code) voor enige andere elektrische apparaten dan producten die uitsluitend door Supermicro zijn aangewezen.

Varoitus! Käytä tuotteen asennuksessa mukana toimitettuja tai tarkoitukseen sopivia liitäntäkaapeleita, virtajohtoja ja verkkolaitteita. Muiden kaapeleiden ja sovittimien käyttö voi aiheuttaa toimintahäiriön tai tulipalon. Sähkölaitteiden ja materiaalien turvallisuutta koskeva laki kieltää UL- tai CSA-sertifioitujen kaapeleiden (joissa on merkintä UL/CSA) käytön muissa sähkölaitteissa kuin Supermicron nimeämässä tuotteissa.

Attention! Lors de l'installation du produit, utilisez les câbles de connexion, les câbles d'alimentation et les adaptateurs secteur fournis ou recommandés. L'utilisation d'autres câbles et adaptateurs peut causer un dysfonctionnement ou un incendie. La loi sur la sécurité des appareils et des équipements électriques interdit l'utilisation de câbles certifiés UL ou CSA (avec la mention UL/CSA sur le cordon) pour tout autre appareil électrique que les produits désignés par Supermicro uniquement.

Warnung! Verwenden Sie bei der Installation des Produkts ausschließlich die vorgesehenen oder mitgelieferten Anschlusskabel, Netzkabel und AC-Adapter. Die Verwendung anderer Kabel oder Adapter kann zu Fehlfunktionen oder Brand führen. Das Gesetz zur Sicherheit elektrischer Geräte und Materialien untersagt die Verwendung von UL- oder CSA-zertifizierten Kabeln (mit UL/CSA-Kennzeichnung auf dem Kabel) für andere elektrische Geräte als die von Supermicro ausdrücklich vorgesehenen Produkte.

אזהרה! בעת התקנת המוצר, יש להשתמש בכבלי החיבור, בכבלי החשמל ובמתאמי ה-AC המצורפים או הייעודיים. שימוש בכבלים או במתאמים אחרים עלול לגרום לתקלה או לדליקה. החוק לבטיחות מכשירי חשמל וחומרים אוסר על שימוש בכבלים בעלי אישור UL או CSA (הנושאים סימון UL/CSA על גבי הכבל) עבור מכשירים חשמליים אחרים שאינם מוצרים ייעודיים של סופרמיקרו (Supermicro) בלבד.

चेतावनी! उत्पाद इंस्टॉल करते समय, प्रदान की गई या निर्दिष्ट कनेक्शन केबल, पावर केबल और AC एडॉप्टर का ही उपयोग करें। किसी अन्य केबल और एडॉप्टर का उपयोग करने से खराबी आ सकती है या आग लग सकती है। विद्युत उपकरण और सामग्री सुरक्षा कानून केवल सुपरमाइक्रो (Supermicro) द्वारा निर्दिष्ट उत्पादों के अलावा किसी अन्य विद्युत उपकरणों के लिए UL या CSA-प्रमाणित केबल (जिनके कॉर्ड पर UL/CSA दर्शाया गया हो) के उपयोग को प्रतिबंधित करता है।

警告！本製品を設置する際は、付属または指定の接続ケーブル、電源コードとACアダプターを使用してください。それ以外のケーブルやアダプターを使用すると、事故や火災の原因になることがあります。電気用品安全法では、ULまたはCSA認定のケーブル（UL/CSAマークがコードに表記）をSupermicroが指定する製品以外の電気機器に使用することを禁止しています。

경고! 제품을 설치할 때 현지 코드 및 적절한 굵기의 코드와 플러그를 포함한 안전 요구 사항을 준수하여 제공되거나 지정된 연결 혹은 구매 케이블, 전원 케이블 및 AC 어댑터를 사용하십시오. 다른 케이블이나 어댑터를 사용하면 오작동이나 화재가 발생할 수 있습니다. 전기 용품 안전 법은 UL 또는 CSA 인증 케이블 (코드에 UL / CSA가 표시된 케이블)을 Supermicro가 지정한 제품 이외의 전기 장치에 사용하는 것을 금지합니다.

Advarsel! Når du installerer produktet, bruker du de medfølgende eller angitte tilkoblingskablene, strømkablene og strømadapterne. Bruk av andre kabler og adaptere kan forårsake funksjonsfeil eller brann. Lov om elektriske apparater og materialsikkerhet forbyr bruk av UL- eller CSA-sertifiserte kabler (der UL/CSA står på ledningen) til andre elektriske apparater enn produkter som kun er angitt av Supermicro.

¡Advertencia! Cuando instale el producto, utilice la conexión provista o designada o procure cables, Cables de alimentación y adaptadores de CA que cumplan con los códigos locales y los requisitos de seguridad, incluyendo el tamaño adecuado del cable y el enchufe. El uso de otros cables y adaptadores podría causar un mal funcionamiento o un incendio. La Ley de Seguridad de Aparatos Eléctricos y de Materiales prohíbe el uso de cables certificados por UL o CSA (que tienen el certificado UL / CSA en el código) para cualquier otros dispositivos eléctricos que los productos designados únicamente por Supermicro.

Varning! När du installerar produkten ska du använda de medföljande eller avsedda anslutningskablarna, strömkablarna och nätadaptarna. Om du använder andra kablar och adaptrar kan det orsaka funktionsfel eller brand. Lagen om säkerhet för elektriska apparater och material förbjuder användning av UL- eller CSA-certifierade kablar (som har UL/CSA angivet på sladden) för andra elektriska apparater än produkter som endast betecknas av Supermicro.

Product Disposal



Warning! Ultimate disposal of this product should be handled according to all national laws and regulations.

تحذير! يجب التخلص النهائي من هذا المنتج وفقاً لجميع القوانين واللوائح الوطنية.

警告！本产品的废弃处理应根据所有国家的法律和规章进行。

警告！本產品的廢棄處理應根據所有國家的法律和規章進行。

Advarsel! Dette produkt skal bortskaffes i henhold til alle nationale love og regler.

Waarschuwing! De uiteindelijke verwijdering van dit product dient te geschieden in overeenstemming met alle nationale wetten en voorschriften.

Varoitus! Tämän tuotteen lopullinen hävittäminen on suoritettava kaikkien kansallisten lakien ja määräysten mukaisesti.

Attention! La mise au rebut ou le recyclage de ce produit sont généralement soumis à des lois et/ou directives de respect de l'environnement. Renseignez-vous auprès de l'organisme compétent.

Warnung! Die endgültige Entsorgung dieses Produkts muss gemäß allen nationalen Gesetzen und Vorschriften erfolgen.

אזהרה! סילוק סופי של מוצר זה חייב להתבצע בהתאם לכל החוקים והתקנות הלאומיים.

चेतावनी! इस उत्पाद का अंतिम निपटान सभी राष्ट्रीय कानूनों और नियमों के अनुसार किया जाना चाहिए।

警告！この製品を廃棄処分する場合、国の関係する全ての法律・条例に従い処理する必要があります。

경고! 이 제품은 해당 국가의 관련 법규 및 규정에 따라 폐기되어야 합니다.

Advarsel! Når produktet til slutt skal kasseres, må det håndteres i henhold til alle nasjonale lover og forskrifter.

¡Advertencia! Al deshacerse por completo de este producto debe seguir todas las leyes y reglamentos nacionales.

Varning! Slutgiltigt bortskaffande av denna produkt ska ske i enlighet med alla nationella lagar och förordningar.

Appendix C:

System Specifications

Processors

Dual Socket BR (LGA-7529)

Intel® Xeon® 6900 series processors with P-cores, up to 128 cores/256 threads, up to 504 MB cache, up to 500 W TDP (air cooled).

Chipset System

System on Chip

BIOS

AMI 32 MB SPI Flash EEPROM

Memory

24 DIMM slots

Max Memory (1DPC): Up to 6 TB, ECC DDR5 RDIMM 6400 MT/s or ECC DDR5 MRDIMM 8800 MT/s

Storage Drives

Internal Storage: Two M.2 NVMe slots (M-key)

Drive Bay Options:

Option A: Eight front hot-swappable E3.S 1T PCIe 5.0 x4 NVMe drive bays

Option B: Eight front hot-swappable E3.L 1T PCIe 5.0 x4 NVMe drive bays

Option C: Eight front hot-swappable 2.5" PCIe 5.0 x4 NVMe drive bays

Expansion Slots

13 PCIe 5.0 x16 FHFL slots (default)

Two M.2 PCIe 5.0 x4 NVMe slots (B+M-key)

Input/Output

LAN: Two RJ45 10 GbE LAN ports (Intel® X710-AT2)

USB: Two USB 3.2 Type-A ports (Rear)

Video: One VGA port

TPM: One TPM header

Motherboard

MBD-X14DBG-AP

Chassis

CSE-418G3TS-R000NFP 4U Rackmount, 17.2" x 7" x 29" (437 x 178 x 737 mm) (W x H x D)

System Cooling

Fans: Ten 8-cm heavy-duty fans with optimal fan speed control

Air Shroud: One primary, up to five optional (depending on add-on cards)

Power Supply

Four 3200 W Redundant (3 + 1) Titanium Level (96%) power supplies

Input:

1400 W: 100–127 VAC / 50-60 Hz / 16–15.4 A

3200 W: 219.1–240 VAC / 50-60 Hz / 16–14.8 A

Operating Environment

Operating Temperature: 10°C to 35°C (50°F to 95°F)

Non-operating Temperature: -40°C to 60°C (-40°F to 140°F)

Operating Relative Humidity: 8% to 90% (non-condensing)

Non-operating Relative Humidity: 5% to 95% (non-condensing)

Regulatory Compliance

FCC, ICES, CE, UKCA, VCCI, RCM, NRTL, CB

Certified Safety Models

Compliant with UL or CSA: 418G3-Q32X14; 481G3-32

Perchlorate Warning

California Best Management Practices Regulations for Perchlorate Materials: This Perchlorate warning applies only to products containing CR (Manganese Dioxide) Lithium coin cells. Perchlorate Material-special handling may apply. See

<https://www.dtsc.ca.gov/hazardouswaste/perchlorate>

Applied Directives, Standards

EMC/EMI: 2014/30/EU (EMC Directive)

Electromagnetic Compatibility Regulations 2016

FCC Part 15 Subpart B

ICES-003

VCCI-CISPR 32

AS/NZS CISPR 32

BS/EN 55032

BS/EN 55035

CISPR 32

CISPR 35

BS/EN 61000-3-2

BS/EN 61000-3-3

BS/EN 61000-4-2

BS/EN 61000-4-3

BS/EN 61000-4-4

BS/EN 61000-4-5

BS/EN 61000-4-6

BS/EN 61000-4-8

BS/EN 61000-4-11

Product Safety: 2014/35/EU (LVD Directive)

UL/CSA 62368-1 (USA and Canada)

Electrical Equipment (Safety) Regulations 2016

IEC/BS/EN 62368-1

Environment:

2011/65/EU (RoHS Directive)

EC 1907/2006 (REACH)

2012/19/EU (WEEE Directive)

California Proposition 65

Appendix D:

General Data Center Environmental Specifications

Particulate Contamination Specifications

Air filtration: Data centers must be kept clean to Class 8 of ISO 14644-1 (ISO 2015). The air entering the data center should be filtered with a MERV 11 filter or better. The air within the data center should be continuously filtered with a MERV 8 filter or better.

Conductive dust: Air should be free of conductive dust, zinc whiskers, or other conductive particles.

Corrosive dust: Air should be free of corrosive dust.

Gaseous Contamination Specifications

Copper coupon corrosion rate: <300 Å/month per class G1 as defined by ANSI.ISA71.04-2013, reference by ASHRAE TC 9.9

Silver coupon corrosion rate: <200 Å/month per class G1 as defined by ANSI.ISA71.04-2013, reference by ASHRAE TC 9.9

Note: If testing with silver or copper coupons results in values less than 200 Å/month or 300 Å/month, respectively, then operating up to 70% relative humidity (RH) is acceptable. If the testing shows corrosion levels exceed these limits, then catalyst type pollutants are probably present and RH should be driven to 50% or lower.