

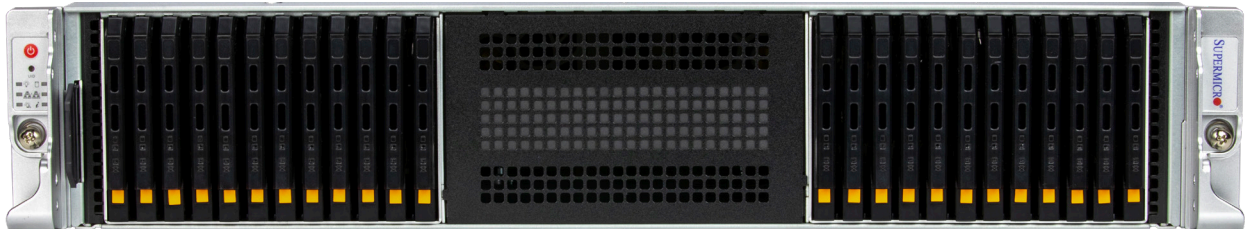

Storage SuperServer[®] SSG-221E-NE324R



USER'S MANUAL

Revision 1.0

The information in this User's Manual has been carefully reviewed and is believed to be accurate. The vendor assumes no responsibility for any inaccuracies that may be contained in this document, and makes no commitment to update or to keep current the information in this manual, or to notify any person or organization of the updates. Please Note: For the most up-to-date version of this manual, please see our website at www.supermicro.com.

Super Micro Computer, Inc. ("Supermicro") reserves the right to make changes to the product described in this manual at any time and without notice. This product, including software and documentation, is the property of Supermicro and/or its licensors, and is supplied only under a license. Any use or reproduction of this product is not allowed, except as expressly permitted by the terms of said license.

IN NO EVENT WILL Super Micro Computer, Inc. BE LIABLE FOR DIRECT, INDIRECT, SPECIAL, INCIDENTAL, SPECULATIVE OR CONSEQUENTIAL DAMAGES ARISING FROM THE USE OR INABILITY TO USE THIS PRODUCT OR DOCUMENTATION, EVEN IF ADVISED OF THE POSSIBILITY OF SUCH DAMAGES. IN PARTICULAR, SUPER MICRO COMPUTER, INC. SHALL NOT HAVE LIABILITY FOR ANY HARDWARE, SOFTWARE, OR DATA STORED OR USED WITH THE PRODUCT, INCLUDING THE COSTS OF REPAIRING, REPLACING, INTEGRATING, INSTALLING OR RECOVERING SUCH HARDWARE, SOFTWARE, OR DATA.

Any disputes arising between manufacturer and customer shall be governed by the laws of Santa Clara County in the State of California, USA. The State of California, County of Santa Clara shall be the exclusive venue for the resolution of any such disputes. Supermicro's total liability for all claims will not exceed the price paid for the hardware product.

FCC Statement: This equipment has been tested and found to comply with the limits for a Class A or Class B digital device pursuant to Part 15 of the FCC Rules. These limits are designed to provide reasonable protection against harmful interference when the equipment is operated in industrial environment for Class A device or in residential environment for Class B device. This equipment generates, uses, and can radiate radio frequency energy and, if not installed and used in accordance with the manufacturer's instruction manual, may cause harmful interference with radio communications. Operation of this equipment in a residential area is likely to cause harmful interference, in which case you will be required to correct the interference at your own expense.

California Best Management Practices Regulations for Perchlorate Materials: This Perchlorate warning applies only to products containing CR (Manganese Dioxide) Lithium coin cells. "Perchlorate Material-special handling may apply. See www.dtsc.ca.gov/hazardouswaste/perchlorate".



WARNING: This product can expose you to chemicals including lead, known to the State of California to cause cancer and birth defects or other reproductive harm. For more information, go to www.P65Warnings.ca.gov.

The products sold by Supermicro are not intended for and will not be used in life support systems, medical equipment, nuclear facilities or systems, aircraft, aircraft devices, aircraft/emergency communication devices or other critical systems whose failure to perform be reasonably expected to result in significant injury or loss of life or catastrophic property damage. Accordingly, Supermicro disclaims any and all liability, and should buyer use or sell such products for use in such ultra-hazardous applications, it does so entirely at its own risk. Furthermore, buyer agrees to fully indemnify, defend and hold Supermicro harmless for and against any and all claims, demands, actions, litigation, and proceedings of any kind arising out of or related to such ultra-hazardous use or sale.

Manual Revision 1.0

Release Date: January 19, 2024

vc

Unless you request and receive written permission from Super Micro Computer, Inc., you may not copy any part of this document. Information in this document is subject to change without notice. Other products and companies referred to herein are trademarks or registered trademarks of their respective companies or mark holders.

Copyright © 2024 by Super Micro Computer, Inc.
All rights reserved.

Printed in the United States of America

Preface

About this Manual

This manual is written for professional system integrators and PC technicians. It provides information for the installation and use of the server. Installation and maintenance should be performed by certified service technicians only.

Please refer to the SSG-221E-NE324R server specifications page on our website for updates on supported memory, processors and operating systems ([http:// www. supermicro. com](http://www.supermicro.com)).

Notes

For your system to work properly, please follow the links below to download all necessary drivers/utilities and the user's manual for your server.

- Supermicro product manuals: <http://www.supermicro.com/support/manuals/>
- Product drivers and utilities: <https://www.supermicro.com/wdl>
- Product safety info: http://www.supermicro.com/about/policies/safety_information.cfm

If you have any questions, please contact our support team at:
support@supermicro.com

This manual may be periodically updated without notice. Please check the Supermicro website for possible updates to the manual revision level.

Secure Data Deletion

A secure data deletion tool designed to fully erase all data from storage devices can be found on our website: https://www.supermicro.com/about/policies/disclaimer.cfm?url=/wdl/utility/Lot9_Secure_Data_Deletion_Utility/

Warnings

Special attention should be given to the following symbols used in this manual.



Warning! Indicates important information given to prevent equipment/property damage or personal injury.



Warning! Indicates high voltage may be encountered when performing a procedure.

Contents

Chapter 1 Introduction

1.1 Overview.....	9
1.2 System Features	10
Front View	10
Drive Carrier Indicators.....	11
Control Panel.....	12
Rear View.....	13
Power Supply Indicator.....	14
1.3 System Architecture	15
1.4 Motherboard Layout	17
Quick Reference Table.....	18
Motherboard Block Diagram	19

Chapter 2 Server Installation

2.1 Overview.....	20
2.2 Unpacking the System	20
2.3 Preparing for Setup.....	20
Choosing a Setup Location.....	20
Rack Precautions	21
Server Precautions.....	21
Rack Mounting Considerations	21
Ambient Operating Temperature.....	21
Airflow	22
Mechanical Loading.....	22
Circuit Overloading	22
Reliable Ground.....	22
2.4 Installing the System into a Rack.....	23
Separating the Sections of the Rack Rails.....	23
Releasing the Inner Rail.....	24
Installing the Inner Rails on the Server	25
Installing the Outer Rails on the Rack.....	26
Installing the Server into the Rack.....	27
Removing the Server from the Rack	28
Removing the Outer Rails from the Rack.....	29

Chapter 3 Maintenance and Component Installation

3.1 Removing Power	30
3.2 Accessing the System.....	31
Removing the Top Cover	31
Front Chassis Cover.....	31
Rear Cover.....	32
Removing the Rear Cover.....	32
3.3 Processor and Heatsink Installation.....	33
The 5th/4th Gen. Intel Xeon Scalable Processor	33
Overview of the CPU Socket	37
Overview of the Processor Carrier Assembly	38
Overview of the Processor Heatsink Module (PHM) with SP XCC and Carrier E1A.....	39
Overview of the Processor Heatsink Module (PHM) with SP MCC and Carrier E1B.....	40
Creating the Processor Carrier Assembly.....	41
Creating the PHM	45
Creating the PHM (1U Heatsink)	46
Creating the PHM (2U Heatsink)	47
Preparing the CPU Socket for Installation	48
Preparing to Install the PHM into the CPU Socket.....	49
Installing the PHM into the CPU Socket.....	52
Removing the PHM from the CPU Socket	55
Removing the Processor Carrier Assembly from the PHM	58
Removing the Processor from the Processor Carrier Assembly	60
3.4 Memory Support and Installation	61
Memory Support.....	61
Memory Population for the X13DSF-A Motherboard.....	63
DIMM Installation	64
DIMM Removal	65
3.5 Motherboard Battery.....	66
3.6 Storage Drives.....	67
Installing Drives.....	67
Drive Carriers	68
Installing a Storage Drive	69
3.7 Installing an OCP NIC Card.....	71
What is an OCP NIC card?	71

3.8 System Cooling	72
Installing the Air Shrouds.....	73
3.9 Power Supply	74
3.10 PCI Expansion Cards	75
3.11 Cable Routing Diagram.....	77
Chapter 4 Motherboard Connections	
4.1 Power Connections	78
4.2 Headers and Connectors	79
4.3 Rear I/O Connectors	82
4.4 Connectors/Ports on the AOM-DSF-IO	83
4.5 Front Control Panel.....	86
Front Control Panel LEDs.....	87
4.6 Jumpers.....	91
4.7 LED Indicators.....	92
Chapter 5 Software	
5.1 Microsoft Windows OS Installation.....	93
5.2 Driver Installation.....	95
5.3 BMC.....	96
BMC ADMIN User Password	96
Chapter 6 Optional Components	
6.1 Storage Control Card and Cable(s)	97
6.2 TPM Security Module.....	98
6.3 Intel Virtual RAID on CPU (VROC).....	99
Requirements and Restrictions	99
Supported SSDs and Operating Systems	99
Additional Information	100
Hardware Key	100
Configuring NVMe RAID Manually.....	101
Status Indications.....	106
Hot Swap Drives	106
Hot-unplug	106
Hot-plug	106
Related Information Links	106

Chapter 7 Troubleshooting and Support

7.1 Information Resources	107
Website	107
Direct Links for the SSG-221E-NE324R System	107
Direct Links for General Support and Information	107
7.2 Baseboard Management Controller (BMC).....	108
7.3 Troubleshooting Procedures	109
No Power	109
No Video	110
System Boot Failure	110
Memory Errors	110
Losing the System Setup Configuration	110
When the System Becomes Unstable	110
7.4 Crash Dump Using BMC.....	112
7.5 CMOS Clear	113
7.6 BMC Reset.....	113
7.7 Where to Get Replacement Components	114
7.8 Reporting an Issue	114
Technical Support Procedures	114
Returning Merchandise for Service.....	114
Vendor Support Filing System	115
7.9 Feedback.....	115

Appendix A Standardized Warning Statements for AC Systems**Appendix B System Specifications**

Contacting Supermicro

Headquarters

Address: Super Micro Computer, Inc.
980 Rock Ave.
San Jose, CA 95131 U.S.A.

Tel: +1 (408) 503-8000

Fax: +1 (408) 503-8008

Email: marketing@supermicro.com (General Information)
Sales-USA@supermicro.com (Sales Inquiries)
Government_Sales-USA@supermicro.com (Gov. Sales Inquiries)
support@supermicro.com (Technical Support)
RMA@supermicro.com (RMA Support)
Webmaster@supermicro.com (Webmaster)

Website: www.supermicro.com

Europe

Address: Super Micro Computer B.V.
Het Sterrenbeeld 28, 5215 ML
's-Hertogenbosch, The Netherlands

Tel: +31 (0) 73-6400390

Fax: +31 (0) 73-6416525

Email: Sales_Europe@supermicro.com (Sales Inquiries)
Support_Europe@supermicro.com (Technical Support)
RMA_Europe@supermicro.com (RMA Support)

Website: www.supermicro.nl

Asia-Pacific

Address: Super Micro Computer, Inc.
3F, No. 150, Jian 1st Rd.
Zhonghe Dist., New Taipei City 235
Taiwan (R.O.C)

Tel: +886-(2) 8226-3990

Fax: +886-(2) 8226-3992

Email: Sales-Asia@supermicro.com.tw (Sales Inquiries)
Support@supermicro.com.tw (Technical Support)
RMA@supermicro.com.tw (RMA Support)

Website: www.supermicro.com.tw

Chapter 1

Introduction

1.1 Overview

This chapter provides an outline of the functions and features of the Storage SuperServer SSG-221E-NE324R. It is based on the X13DSF-A motherboard and the CSE-236E3-R2K08P chassis. The following provides an overview of the specifications and capabilities of the SSG-221E-NE324R.

System Overview	
Motherboard	X13DSF-A
Chassis	CSE-236E3-R2K08P
Processors	Dual 5th/4th Gen Intel® Xeon® Scalable processors with 4 UPI (16 GT/s max) and a total of 160 Gen5 PCIe lanes in a Socket E (LGA-4677), supports up to 350 W TDP
Memory	32 DIMM slots up to 8 TB, 1 DPC ECC DDR5 RDIMM/LRDIMM for up to 5600 MT/s
Storage	24 hot-swap E3.S (7.5 mm) NVMe drive bays Two 2.5" hot-swap SATA drive bays Two PCIe 3.0 (NVMe or SATA3 hybrid slots) with support of M-Key 2280 and 22110
Expansion Slots	Two PCIe 5.0 x8 slots (full-height, full-length) One PCIe 5.0 x16 slot (full-height, full-length; x8 when slots 1 and 2 are used) One PCIe 5.0 x16 slot (full-height, full-length; x8 when slots 3 and 4 are used) Two PCIe 5.0 AIOM slots
I/O Ports	Two rear USB 3.0 ports One rear dedicated IPMI LAN port One rear VGA port
System Cooling	Eight heavy duty 8-cm fans with optimal fan speed control One air shroud
Power	Two redundant 2000 W power supplies, 80Plus Titanium level
Form Factor	2U; (WxHxD) 17.2" x 3.5" x 30.8" in. (438 x 90 x 790 mm)

A Quick Reference Guide can be found on the product page of the Supermicro website.

The following safety models associated with the SSG-221E-NE324R have been certified as compliant with: 126ES2-R20X13.

1.2 System Features

The following views of the system display the main features.

Front View

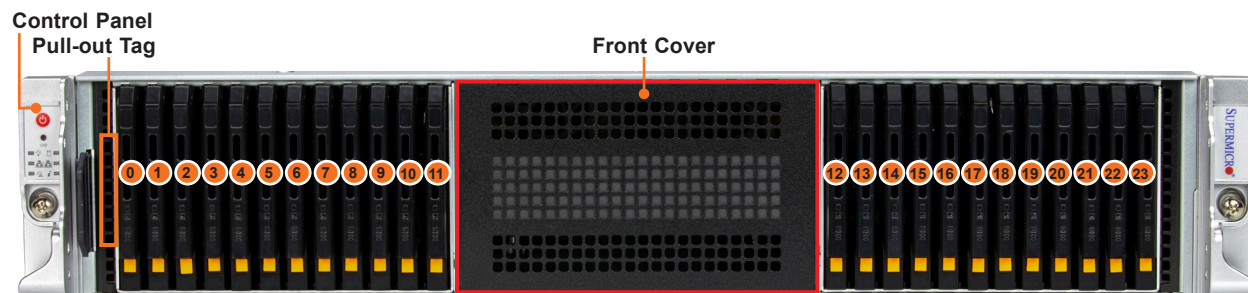

Figure 1-1. Front View

System Features: Front	
Feature	Description
Control Panel	Front control panel with LEDs and buttons (see Control Panel for details)
Pull-out Tag	Pull-out service or asset tag has the BMC password details
Front Cover	Front dummy cover for the standard 24 drive bay configuration Note: An optional configuration for an additional 32 drive bays will be available soon.

Logical Storage Drive Numbers	
Item	Description
0-23	24 hot-swap E3.S drive bays (supports 7.5 mm form factor)

Drive Carrier Indicators

Each drive carrier has two LED indicators: an activity indicator and a status indicator. For RAID configurations using a controller, the meaning of the status indicator is described in the table below. For OS RAID or non-RAID configurations, some LED indications are not supported, such as hot spare.

Drive Carrier LED Indicators			
	Color	Blinking Pattern	Behavior for Device
Activity LED	Blue	Solid On	Idle SAS/NVMe drive installed
	Blue	Blinking	I/O activity
	Off		Idle SATA drive installed
Status LED	Red	Solid On	Failure of drive with RSTe support
	Red	Blinking at 1 Hz	Rebuild drive with RSTe support
	Red	Blinking with two blinks and one stop at 1 Hz	Hot spare for drive with RSTe support
	Red	On for five seconds, then off	Power on for drive with RSTe support
	Red	Blinking at 4 Hz	Identify drive with RSTe support
	Green	Solid on	Safe to remove NVMe drive
	Amber	Blinking at 1 Hz	Do not remove NVMe drive

Control Panel

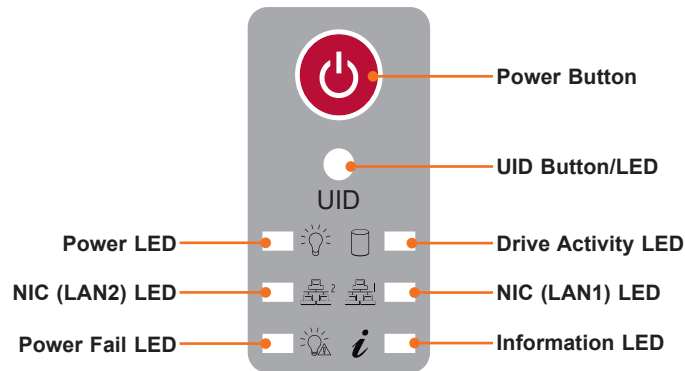

Figure 1-2. Control Panel

Control Panel Features	
Feature	Description
Power Button	The main power switch applies or removes primary power from the power supplies to the server but maintains standby power.
UID Button/LED	The unit identification (UID) button turns on or off the blue light function of the Information LED and a blue LED on the rear of the chassis.
Power LED	Indicates power is being supplied to the system power supply units. This LED is illuminated when the system is operating normally.
Drive Activity LED	Indicates activity on the storage drives when flashing.
NIC (LAN1) LED	Indicates network activity on LAN1 when flashing.
NIC (LAN2) LED	Indicates network activity on LAN2 when flashing.
Power Fail LED	Indicates a power supply module has failed.
Information LED	Alerts operator to several states, as noted in the table below.

Information LED	
Color, Status	Description
Red, solid	An overheat condition has occurred.
Red, blinking at 1 Hz	Fan failure. Check for an inoperative fan.
Red, blinking at 0.25 Hz	Power failure. Check for a non-operational power supply.
Red, solid, with Power LED blinking green	Fault detected
Blue and red, blinking at 10 Hz	Recovery mode
Blue, solid	UID has been activated locally to locate the server in a rack environment.
Blue, blinking at 1 Hz	UID has been activated using the BMC to locate the server in a rack environment.
Blue, blinking at 2 Hz	BMC is resetting
Blue, blinking at 4 Hz	BMC is setting factory defaults
Blue, blinking at 10 Hz with Power LED blinking green	BMC/BIOS firmware is updating

Rear View

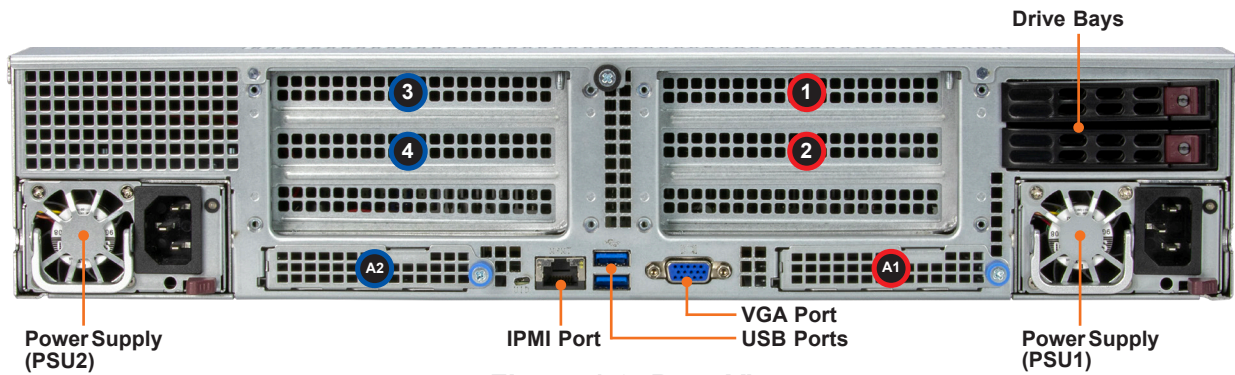

Figure 1-3. Rear View

System Features: Rear	
Feature	Description
Power Supplies	Two redundant 2000 W power supply modules (PSU1 on the right, PSU2 left)
IPMI LAN Port	One rear RJ45 dedicated 1 GbE IPMI port
USB Ports	Two USB 3.0 ports
VGA Port	One video port
Drive Bays	Two 2.5" hot-swap SATA drive bays

Expansion Slot Locations	
Slot	Description
1, 2	PCIe FHHL Gen5 x8 (slot 1) x16 (slot 2). x8 mode when slots 1 and 2 are used.
3, 4	PCIe FHHL Gen5 x8 (slot 3) x16 (slot 4). x8 mode when slots 3 and 4 are used.
A1, A2	Gen5 AIOM1, AIOM2

CPU1 ■ CPU2 ■

Power Supply Indicator

Power Supply Indicator	
LED Color and State	Power Supply Condition
Off	No AC power to modules
Amber, solid	AC cord unplugged and in redundant mode OR power supply critical events causing a shutdown, failure, OCP, OVP, fan fail, OTP, UVP
Amber, blinking	Power supply warning events where the power supply continues to operate: high temperature, over voltage, under voltage, etc
Green, blinking	AC present, only 12 vsb on (module off)
Green, solid	Output on, functioning normally

1.3 System Architecture

This section shows the locations of the system's main components.

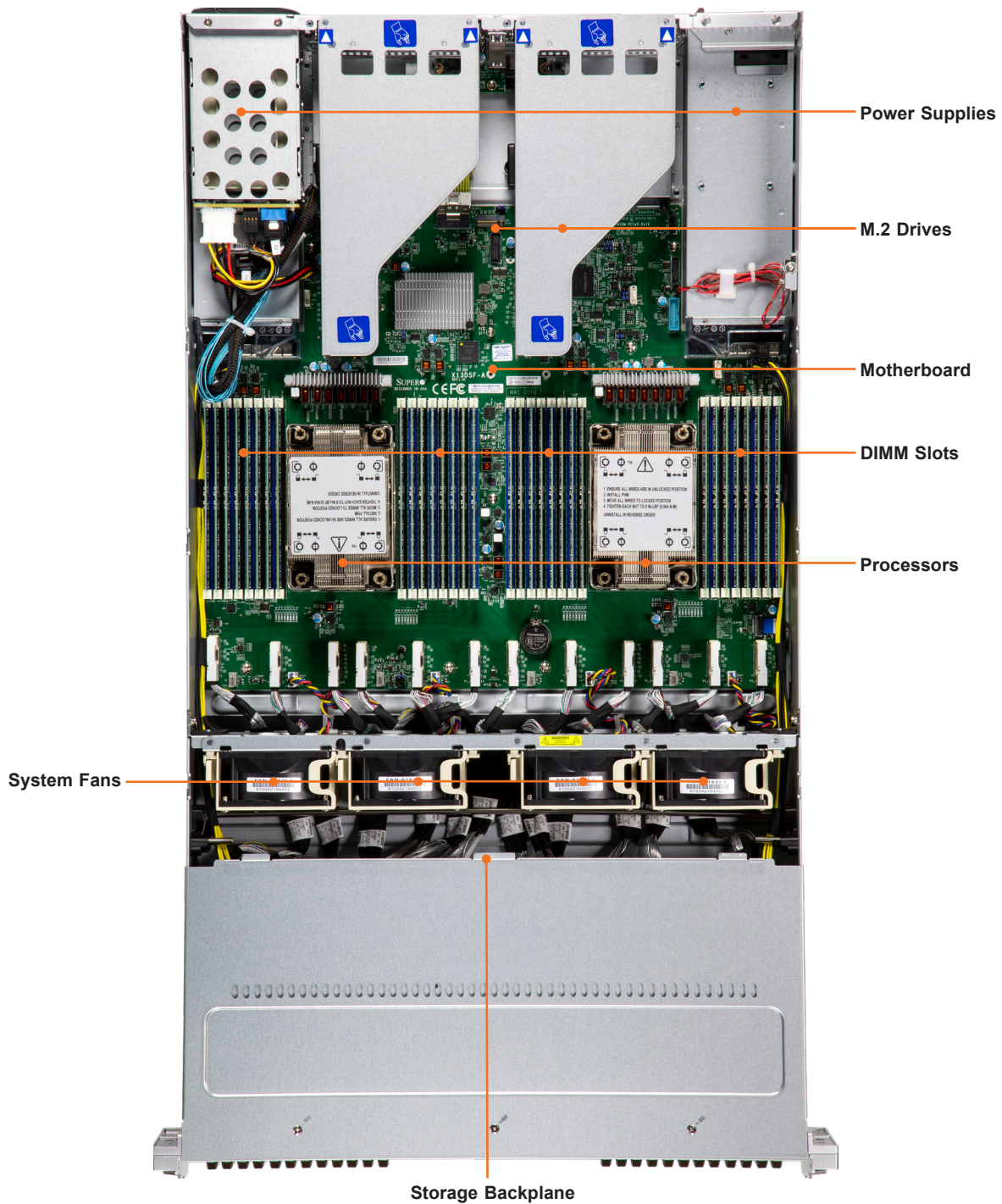

Figure 1-4. Main Component Locations

System Features: Top	
Feature	Description
Power Supplies	Dual redundant modules, PWS-2K08A-1R
M.2 Drives	Two M.2 NVMe/SATA drives
Motherboard	X13DSF-A
DIMM Slots	32 DDR5 DIMM slots
Processors	Dual 5th/4th Gen Intel® Xeon® Scalable processors (up to 350 W) with heatsinks, SNK-P0088P
System Fans	Four 8-cm fans with optimal fan speed control, FAN-0162L4
Storage Backplane	Dual storage backplanes supports 24 E3.S NVMe SSD drives, BPN-E3S5-236N

1.4 Motherboard Layout

Below is a layout of the X13DSF-A motherboard with the jumper, connector and LED locations shown. See the table on the following page for descriptions. For detailed descriptions, pinout information and jumper settings, refer to [Chapter 4](#) or the [Motherboard Manual](#).

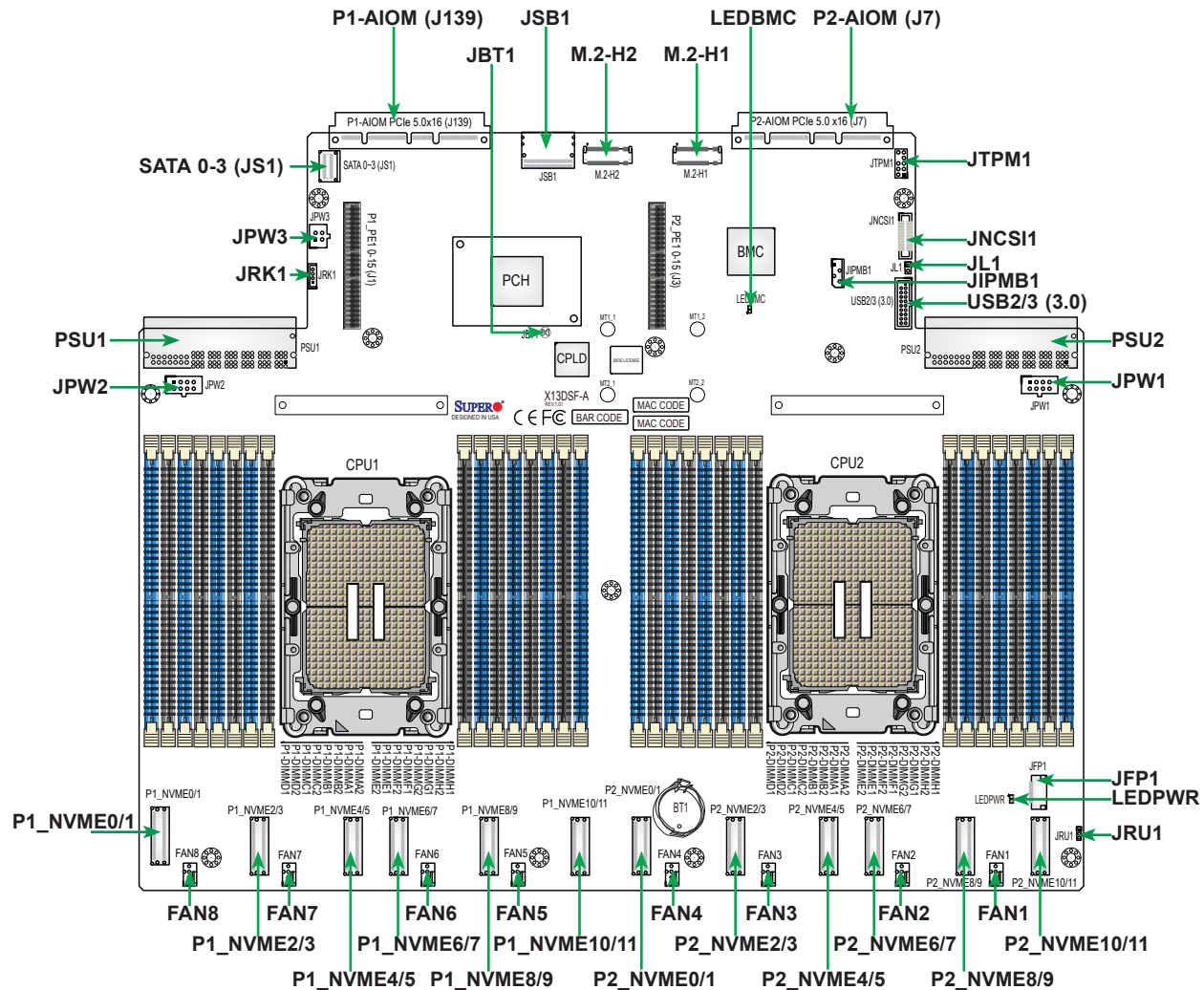

Figure 1-5. Motherboard Layout

Notes:

- "■" indicates the location of Pin 1.
- Jumpers/LED indicators not indicated are used for testing only.
- Use only the correct p1 type of onboard CMOS battery as specified by the manufacturer. To avoid a possible explosion, do not install the onboard battery upside down.

Quick Reference Table

Jumper	Description	Default Setting
JBT1	CMOS Clear	Open (Normal)
JRU1	UID LED/BMC Reset/System Reset	Pins 1-2: UID LED/BMC Reset Pins 2-3: System Reset

LED	Description	Status
LEDBMC	BMC Heartbeat LED	Blinking Green: BMC Normal (Active), Solid Green: During BMC Reset or during a Cold Reboot
LEDPWR	Power LED	LED On: Onboard Power On

Connector	Description
BT1	Onboard CMOS Battery
FAN1 – FAN8	4-pin Cooling Fan Headers
JFP1	Front Control Panel Header with I ² C
JIPMB1	4-pin BMC External I2C Header
JL1	Chassis Intrusion Header
JNCSI1	Network Controller Sideband Interface (NC-SI) Connector for BMC shared LAN
JPW1, JPW2	8-pin Power Connectors
JPW3	4-pin Power Connector
JRK1	Intel VROC Key Header
JSB1	Rear I/O Module Connector
JTPM1	Trusted Platform Module/Port 80 Connector
M.2-H1, M.2-H2	NVMe PCIe 3.0 x4 / SATA 3.0 Hybrid M.2 Slots (Support M-Key 2280 and 22110)
MT1_1, MT2_1; MT1_2, MT2_2	MT1_1, MT2_1: M.2-H1 Mounting Holes; MT1_2, MT2_2: M.2-H2 Mounting Holes
P1-AIOM (J139), P2-AIOM (J7)	Supermicro Advanced Input/Output Module (AIOM) PCIe 5.0 x16 Connectors for rear I/O support (OCP 3.0 SFF compliant)
P1_NVME0/1 – P1_NVME10/11	Six PCIe 5.0 x8 MCIO Connectors supported by CPU1
P2_NVME0/1 – P2_NVME10/11	Six PCIe 5.0 x8 MCIO Connectors supported by CPU2
P1_PE1 0-15 (J1)	GenZ x16 Slot (PCIe 5.0) supported by CPU1
P2_PE1 0-15 (J3)	GenZ x16 Slot (PCIe 5.0) supported by CPU2
PSU1, PSU2	Power Supply Unit Connectors for system power use
SATA 0-3 (JS1)	SlimSAS LP Connector with support of four Intel PCH SATA 3.0 connections (Supports RAID 0, RAID 1, RAID 5, and RAID 10)
USB2/3 (3.0)	USB 3.0 Header for front panel USB 3.0 ports

Motherboard Block Diagram

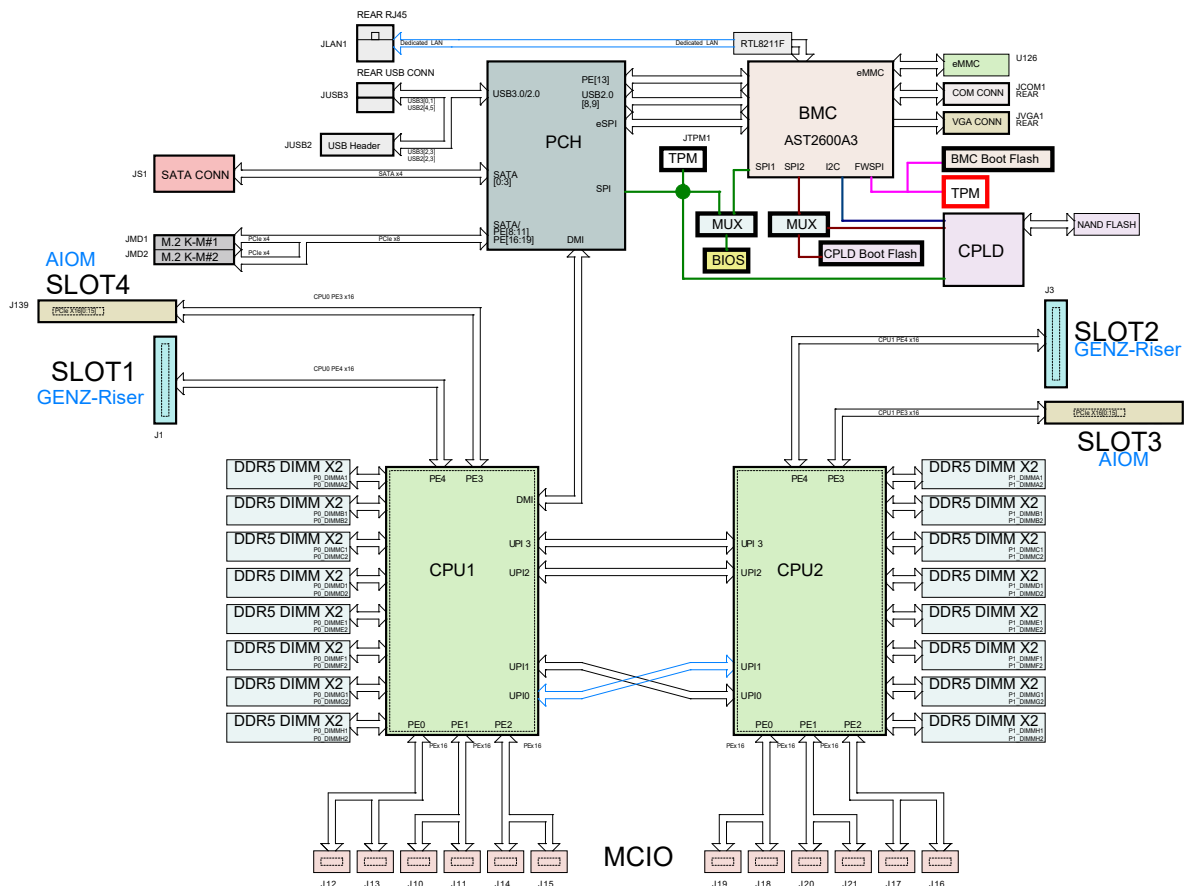

Figure 1-6. Motherboard Block Diagram

Chapter 2

Server Installation

2.1 Overview

This chapter provides advice and instructions for mounting your system in a server rack. If your system is not already fully integrated with processors, system memory etc., refer to [Chapter 3](#) for details on installing those specific components.

Caution: Electrostatic Discharge (ESD) can damage electronic components. To prevent such damage to PCBs (printed circuit boards), it is important to use a grounded wrist strap, handle all PCBs by their edges and keep them in anti-static bags when not in use.

2.2 Unpacking the System

Inspect the box in which the system was shipped, and note if it was damaged. If any equipment appears damaged, file a claim with the carrier.

Decide on a suitable location for the rack unit that will hold the server. It should be situated in a clean, dust-free area that is well ventilated. Avoid areas where heat, electrical noise and electromagnetic fields are generated. It will also require a grounded AC power outlet nearby. Be sure to read the precautions and considerations noted in [Appendix A](#).

2.3 Preparing for Setup

The box in which the system was shipped should include the rackmount hardware needed to install it into the rack. Please read this section in its entirety before you begin the installation.

Choosing a Setup Location

- The system should be situated in a clean, dust-free area that is well ventilated. Avoid areas where heat, electrical noise and electromagnetic fields are generated.
- Leave enough clearance in front of the rack so that you can open the front door completely (approximately 25 inches) and approximately 30 inches of clearance in the back of the rack to allow sufficient space for airflow and access when servicing.
- This product should be installed only in a Restricted Access Location (dedicated equipment rooms, service closets, etc.).

- This product is not suitable for use with visual display workplace devices according to §2 of the German Ordinance for Work with Visual Display Units.

Rack Precautions

- Ensure that the leveling jacks on the bottom of the rack are extended to the floor so that the full weight of the rack rests on them.
- In single rack installations, stabilizers should be attached to the rack. In multiple rack installations, the racks should be coupled together.
- Always make sure the rack is stable before extending a server or other component from the rack.
- You should extend only one server or component at a time - extending two or more simultaneously may cause the rack to become unstable.

Server Precautions

- Review the electrical and general safety precautions in [Appendix A](#).
- Determine the placement of each component in the rack *before* you install the rails.
- Install the heaviest server components at the bottom of the rack first and then work your way up.
- Use a regulating uninterruptible power supply (UPS) to protect the server from power surges and voltage spikes and to keep your system operating in case of a power failure.
- Allow any drives and power supply modules to cool before touching them.
- When not servicing, always keep the front door of the rack and all covers/panels on the servers closed to maintain proper cooling.

Rack Mounting Considerations

Ambient Operating Temperature

If installed in a closed or multi-unit rack assembly, the ambient operating temperature of the rack environment may be greater than the room's ambient temperature. Therefore, consideration should be given to installing the equipment in an environment compatible with the manufacturer's maximum rated ambient temperature (TMRA).

Airflow

Equipment should be mounted into a rack so that the amount of airflow required for safe operation is not compromised.

Mechanical Loading

Equipment should be mounted into a rack so that a hazardous condition does not arise due to uneven mechanical loading.

Circuit Overloading

Consideration should be given to the connection of the equipment to the power supply circuitry and the effect that any possible overloading of circuits might have on overcurrent protection and power supply wiring. Appropriate consideration of equipment nameplate ratings should be used when addressing this concern.

Reliable Ground

A reliable ground must be maintained at all times. To ensure this, the rack itself should be grounded. Particular attention should be given to power supply connections other than the direct connections to the branch circuit (i.e. the use of power strips, etc.).



To prevent bodily injury when mounting or servicing this unit in a rack, you must take special precautions to ensure that the system remains stable. The following guidelines are provided to ensure your safety:

- This unit should be mounted at the bottom of the rack if it is the only unit in the rack.
- When mounting this unit in a partially filled rack, load the rack from the bottom to the top with the heaviest component at the bottom of the rack.
- If the rack is provided with stabilizing devices, install the stabilizers before mounting or servicing the unit in the rack.
- Slide rail mounted equipment is not to be used as a shelf or a work space.

2.4 Installing the System into a Rack

This section provides information on installing the SSG-221E-NE324R into a rack unit with the quick-release rails provided. There are a variety of rack units on the market, which may mean the assembly procedure will differ slightly. You should also refer to the installation instructions that came with the rack unit you are using.

Note: This rail will fit a rack between 26.5" and 36.4" deep.

Separating the Sections of the Rack Rails

The chassis package includes two rail assemblies in the rack mounting kit. Each assembly consists of three sections: An inner rail that secures directly to the chassis, an outer rail that secures to the rack, and a middle rail that slides in the outer rail. These assemblies are specifically designed for the left and right side of the chassis.

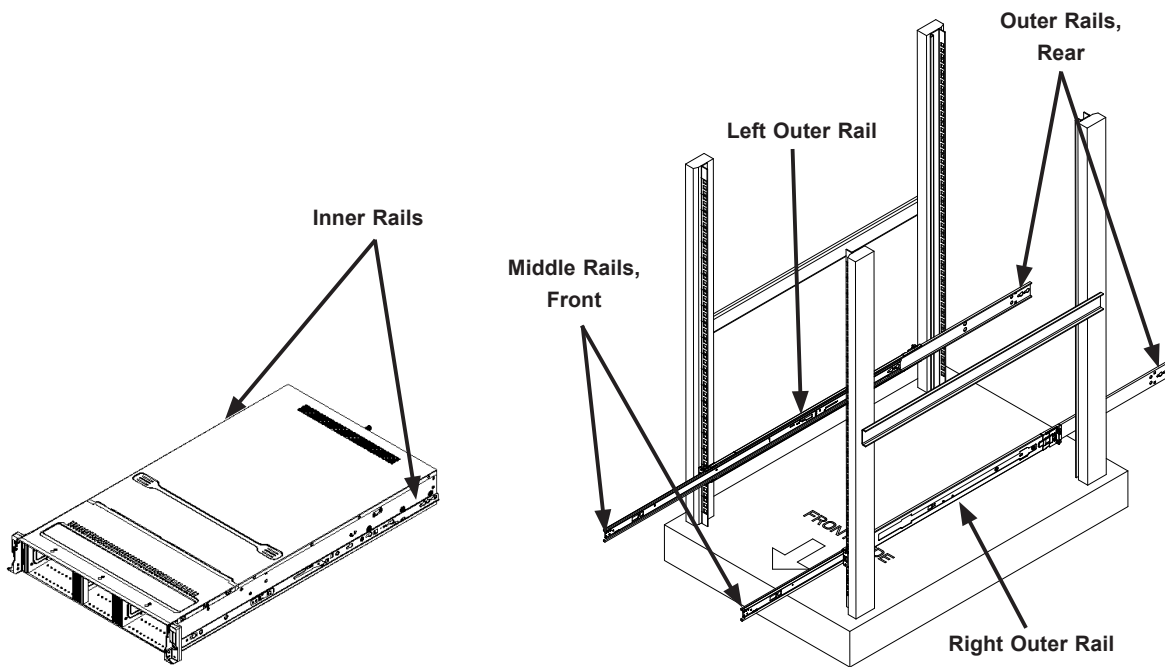

Figure 2-1. Identifying the Inner Rails, Middle Rails and Outer Rails

Note: Figures are for illustrative purposes only. Your actual chassis may differ. Always install servers into racks from the bottom up.



Slide rail mounted equipment is not to be used as a shelf or a work space.



Warning: Do not pick up the server with the front handles. They are designed to pull the system from a rack only.

Releasing the Inner Rail

It is necessary to release the inner rail from the middle and outer rails before installing the inner rail on the chassis.

Releasing the Inner Rail from the Middle and Outer Rails

1. Lift the front latch on the inner rail and pull the inner rail out of the middle rail, and the middle rail out of the outer rail until the rails are fully extended.
2. Press down the locking lever on the inside of the inner rail to release the inner rail. Continue to pull the inner rail out of the middle rail.

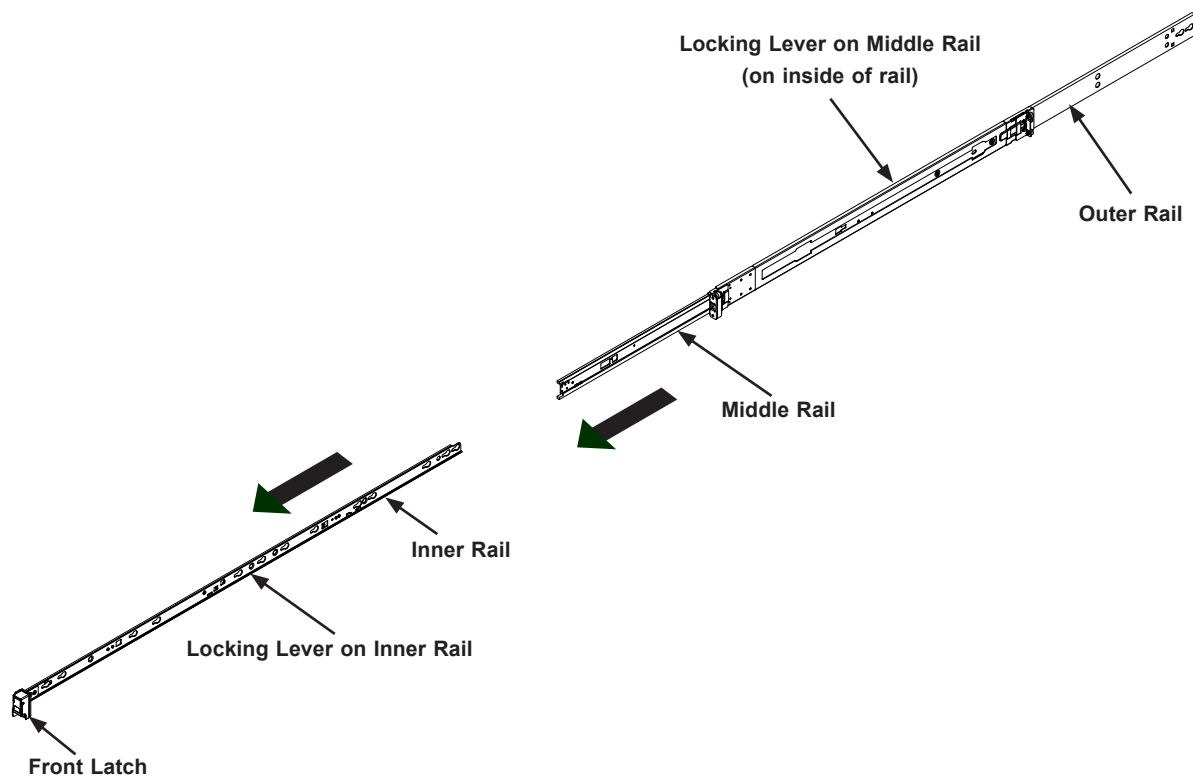

Figure 2-2. Extending the Rails and Releasing the Inner Rail



Warning: Stability hazard. The rack stabilizing mechanism must be in place, or the rack must be bolted to the floor before you slide the unit out for servicing. Failure to stabilize the rack can cause the rack to tip over.

Installing the Inner Rails on the Server

Installing the Inner Rails

1. Confirm that the left and right inner rails have been correctly identified.
2. Place the inner rail firmly against the side of the chassis, aligning the pins on the side of the chassis with the slotted thru holes in the inner rail.
3. Slide the inner rail toward the rear of the chassis until the pins are at the end of the narrow slot, which secures the inner rail to the chassis. An optional screw may be added for extra security.
4. Repeat for the other inner rail.

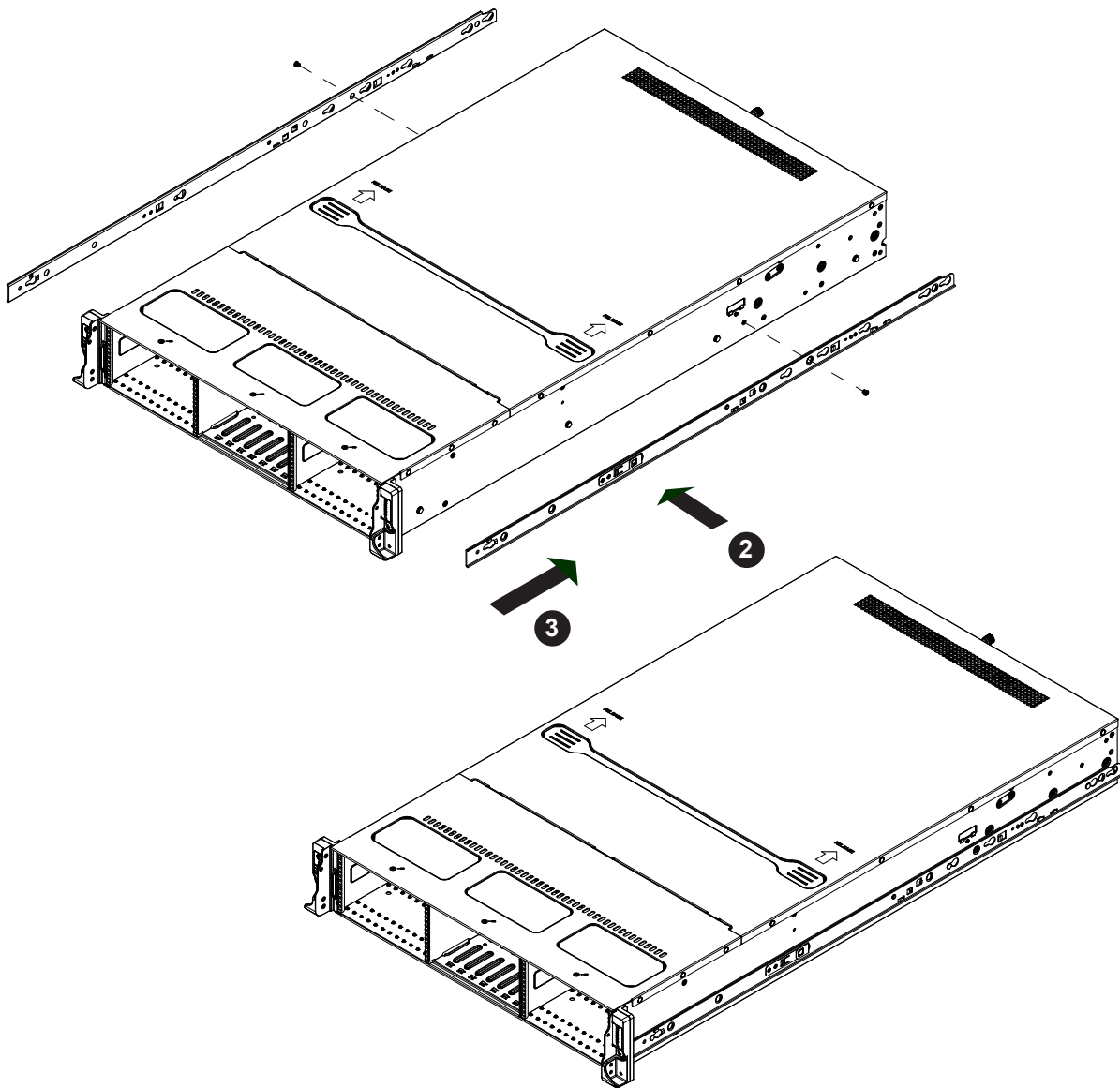

Figure 2-3. Installing the Inner Rails

Installing the Outer Rails on the Rack

Installing the Outer Rails

1. Confirm that the left and right outer rails have been correctly identified.
2. Release the small locking lever on the inside of the middle rail and push the middle rail back into the outer rail.
3. Insert the pins at the front of the outer rail into the square holes on the front of the rack. Push until the latch snaps into place.
4. The outer rail is actually two pieces that slide to lengthen. Pull out the rear of the outer rail, adjusting the length until the square pin assembly passes, then fits against the back of the rear post. Be careful to keep the rail level.
5. Insert the pins at the rear of the outer rail into the square holes on the rear of the rack. Push until the latch snaps into place.
6. Repeat for the other outer rail.

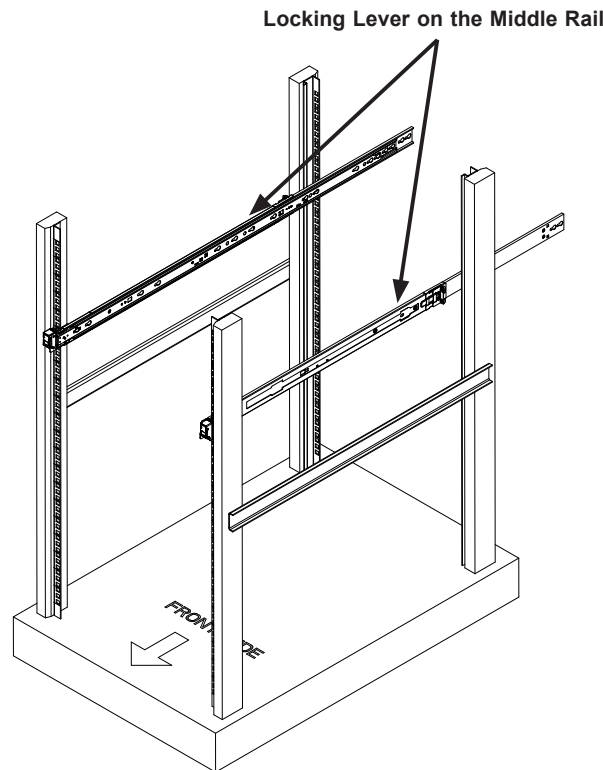

Figure 2-4. Installing the Outer Rails

Note: Figures are for illustrative purposes only. Your actual chassis may differ. Always install servers into racks from the bottom up.

Installing the Server into the Rack

After the rails are installed on the chassis and on the rack, the server can be installed in the rack. It is heavy and requires two to three people to lift.

Installing the System into a Rack

1. Pull both middle rails out the front of the outer rail until each clicks to a stop.
2. Align the inner rails on the chassis with the front of the middle rails.
3. Slide the inner rails on the chassis into the middle rails, keeping the pressure even on both sides. When partially in, the locking levers will stop further progress.
4. Press down the locking levers on the inside of the inner rails and push the chassis all the way into the rear of the rack. The front latches will click into place.

The chassis is now mounted in the rack. It can be pulled partially out for service by lifting both front latches.

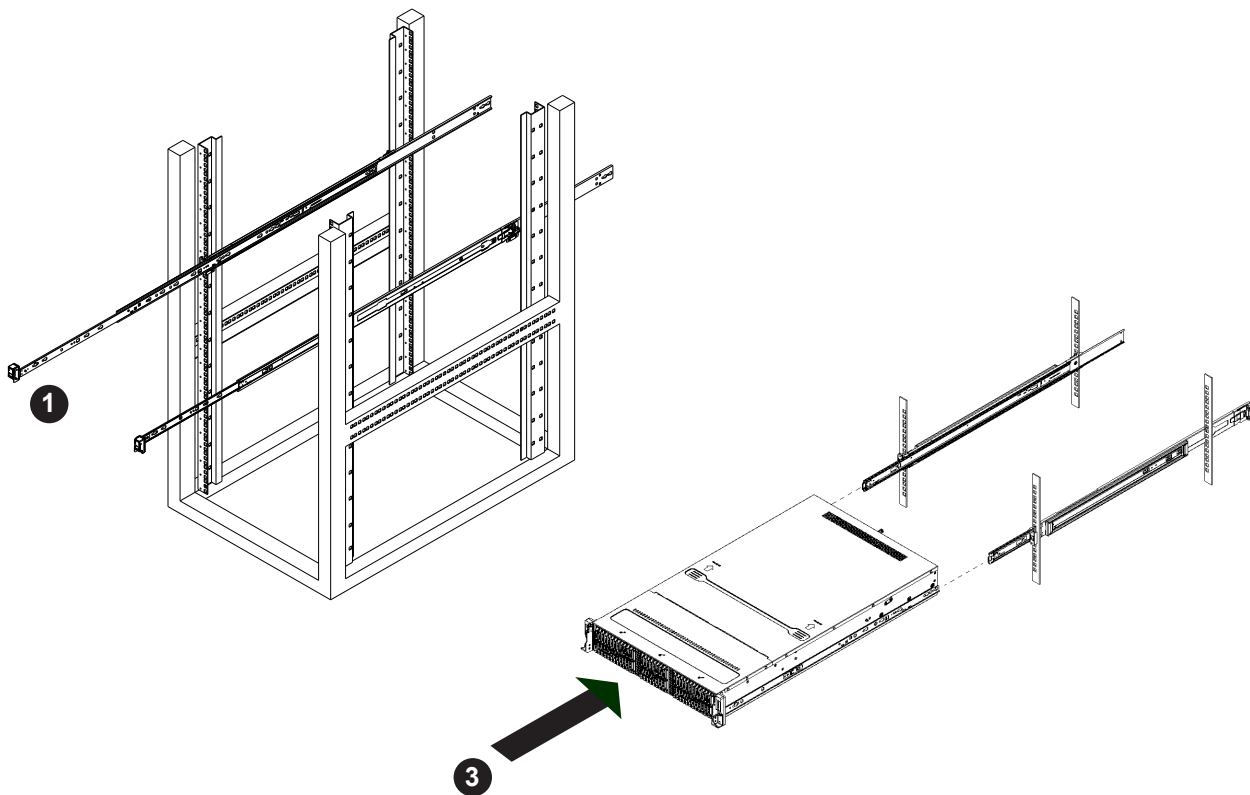

Figure 2-5. Installing the Server into the Rack

Note: Figures are for illustrative purposes only. Your actual chassis may differ. Always install servers into racks from the bottom up.

Removing the Server from the Rack

Caution: The chassis is heavy and requires two to three people to lift it out.

Removing the Server

1. Remove the right and left front screws that are on either side of the front of the chassis.
2. Pull the chassis forward until it clicks to a stop.
3. Press down the locking lever on the inside of the inner rail (Figure 2-2) to release the chassis. Continue to pull the chassis out of the middle rails.

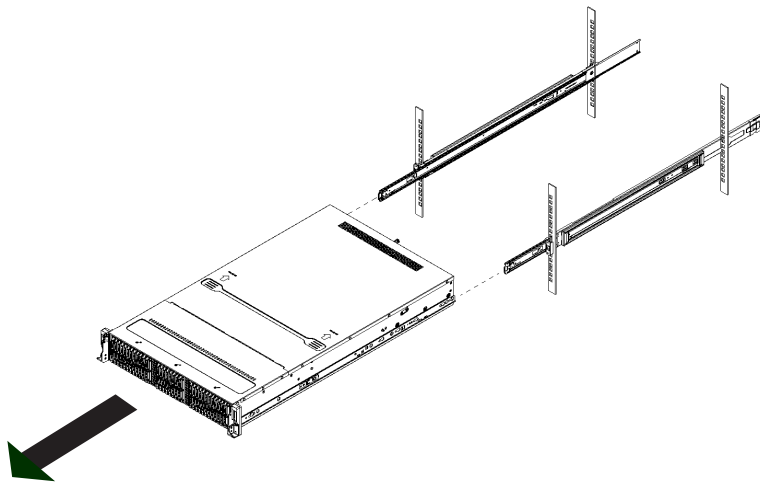

Figure 2-6. Removing the Server from the Rack

Removing the Outer Rails from the Rack

In the uncommon event that it is necessary to remove the outer rails from the rack, follow these instructions. The chassis must be out of the rack.

Releasing the Outer Rails

1. On the front of the outer rail, slide the small plastic safety slider (red in drawing) up and hold it while pushing the plastic release button (green in drawing) just below it.
2. While holding the release button in, pull the outer rail forward to disengage the pins and the front of the rail from the rack.
3. Support the front of the outer and middle rail assembly while releasing the rear.
4. Remove the outer rail from the rear of the rack in the same way as the front. Slide the safety slider up and push and hold the release button, then pull the rear pins out of the rack and remove the rail.

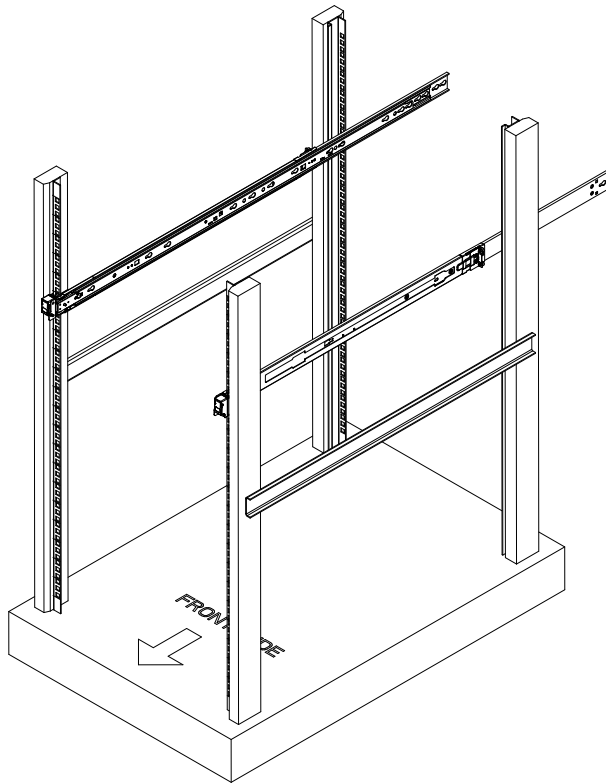

Figure 2-7. Removing the Outer Rails

Chapter 3

Maintenance and Component Installation

This chapter provides instructions on installing and replacing main system components. To prevent compatibility issues, only use components that match the specifications and/or part numbers given.

Installation or replacement of most components require that power first be removed from the system. Please follow the procedures given in each section.

3.1 Removing Power

Use the following procedure to ensure that power has been removed from the system. This step is necessary when removing or installing non hot-swap components or when replacing a non-redundant power supply.

1. Use the operating system to power down the system.
2. After the system has completely shut down, disconnect the AC power cord(s) from the power strip or outlet. (If your system has more than one power supply, remove the AC power cords from all power supply modules.)
3. Disconnect the power cord(s) from the power supply module(s).

Note: This caution statement applies when changing any component or subsystem that is not hot-swap/hot-plug.

3.2 Accessing the System

The SSG-221E-NE324R features a removable top cover for access to the internal components. When performing service on components inside the system, remove the system from the rack and place it on a work bench or desk. Do not service with the system extended from the rack.

Removing the Top Cover

Front Chassis Cover

The front-chassis cover can be removed to access the drive bays while the server continues to operate.

Removing the Front Chassis Cover

Remove the five screws securing the front side of the cover, then lift the cover.

Warning: Except for short periods of time, do not operate the server without the cover in place. The chassis cover must be in place to allow for proper airflow and to prevent overheating.

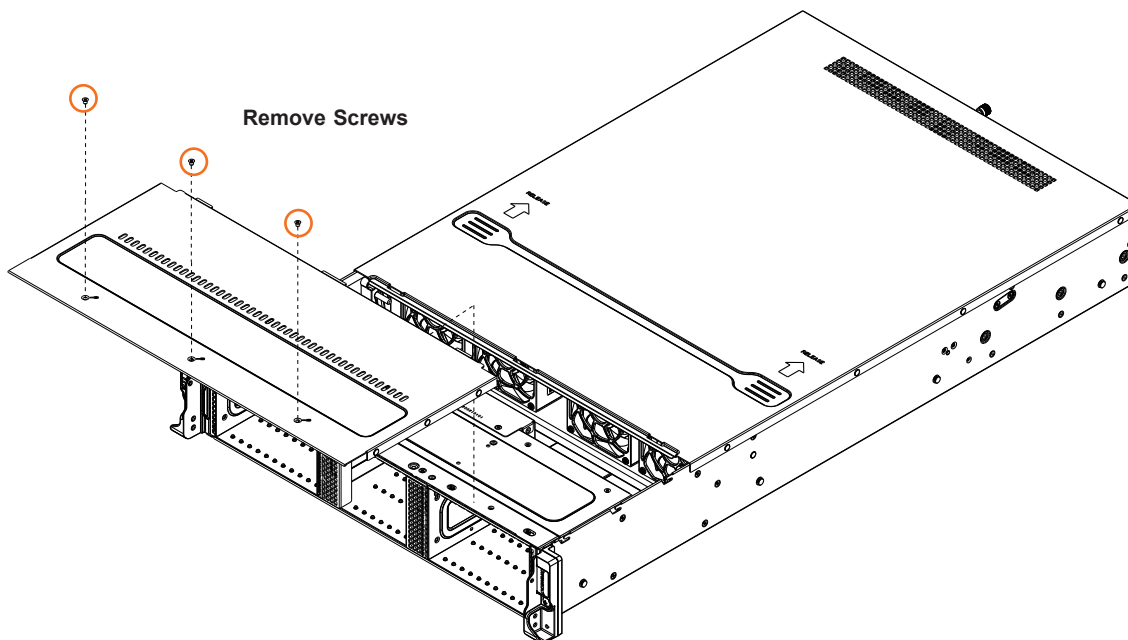

Figure 3-1. Removing the Front Chassis Cover

Rear Cover

Removing the Rear Cover

Remove the thumb screw from the rear of the chassis, push the two release buttons located on top of the chassis to release the cover, then slide the cover to the rear and off.

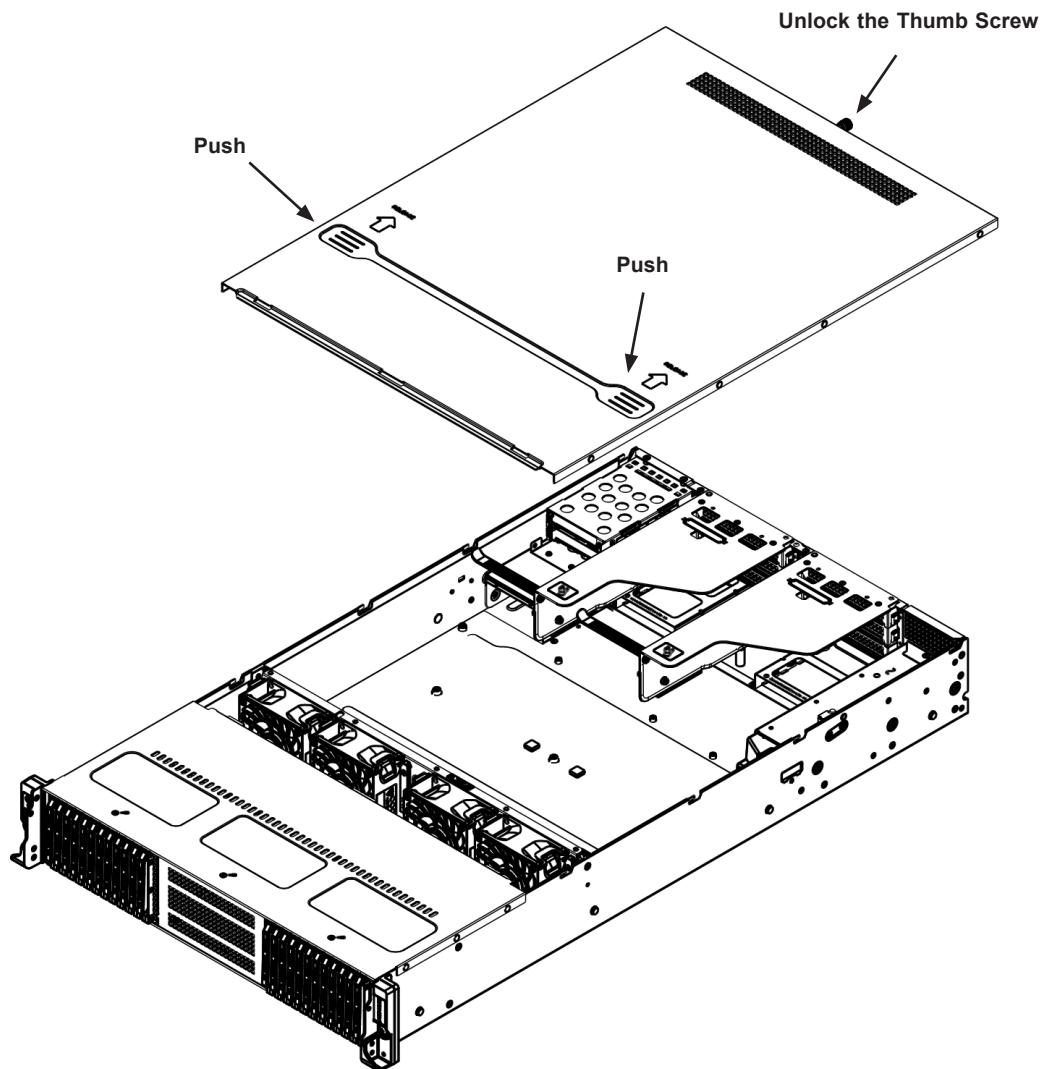

Figure 3-2. Removing the Rear Cover

3.3 Processor and Heatsink Installation

The processor (CPU) and processor carrier should be assembled together first to form the processor carrier assembly. This assembly will be then attached to the heatsink to form the processor heatsink module (PHM) before being installed into the CPU socket. Before installation, be sure to perform the following steps:

- Please carefully follow the instructions given on the previous page to avoid ESD-related damages.
- Unplug the AC power cords from all power supplies after shutting down the system.
- Check that the plastic protective cover is on the CPU socket, and none of the socket pins are bent. If they are, contact your retailer.
- When handling the processor, avoid touching or placing direct pressure on the LGA lands (gold contacts). Improper installation or socket misalignment can cause serious damage to the processor or CPU socket, which may require manufacturer repairs.
- Thermal grease is pre-applied on a new heatsink. No additional thermal grease is needed.
- Refer to the Supermicro website for updates on processor and memory support.
- All graphics in this manual are for illustrations only. Your components may look different.

The 5th/4th Gen. Intel Xeon Scalable Processor

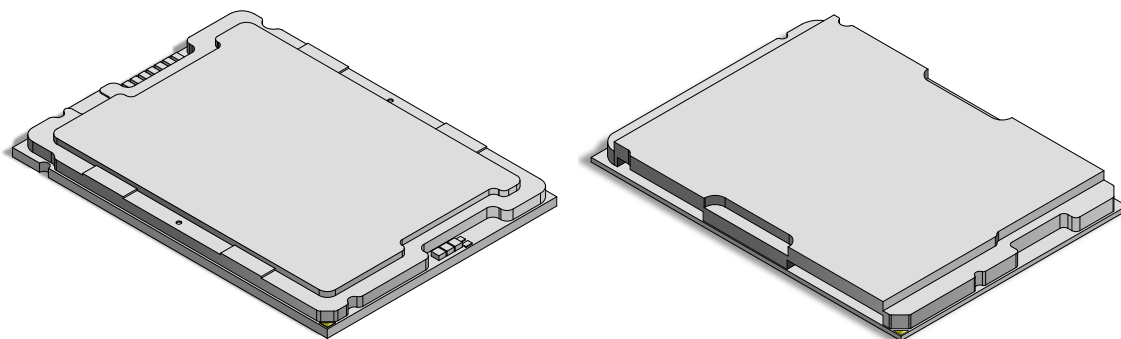

SP XCC

SP MCC

Processor Top View

1. The 5th/4th Gen. Intel Xeon Scalable Processor

Processor Top View

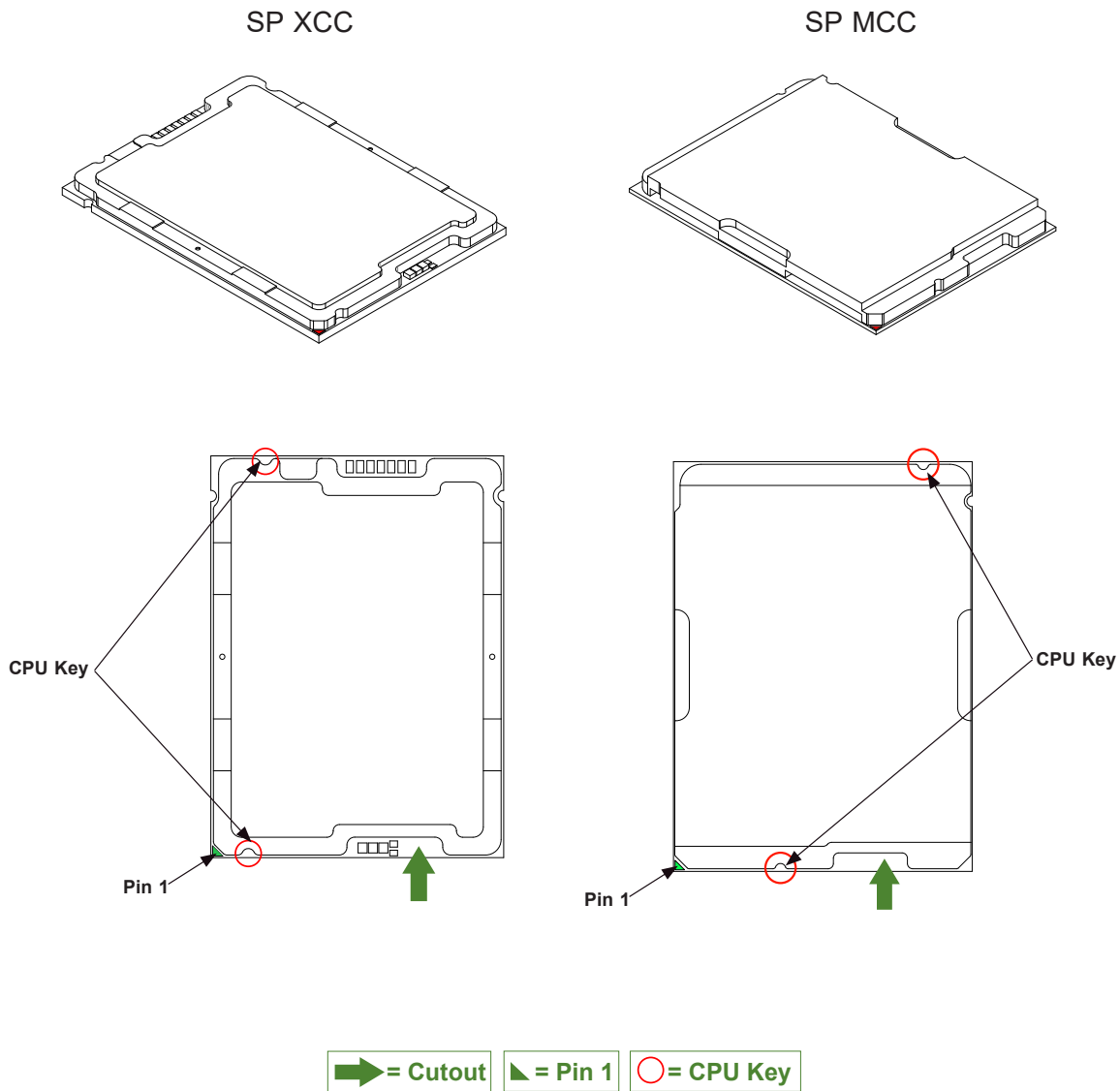

2. The Processor Carrier

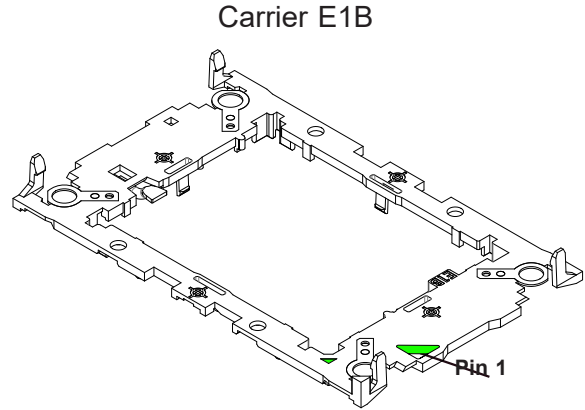
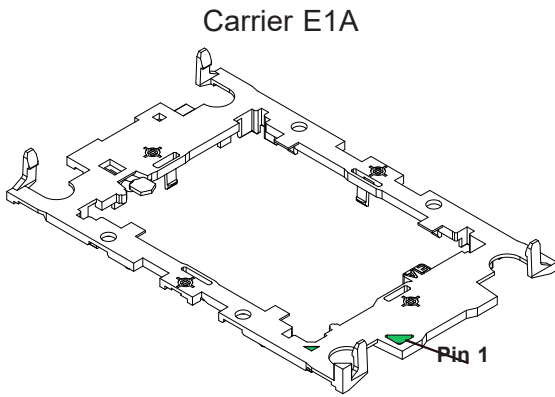

Carrier Top View

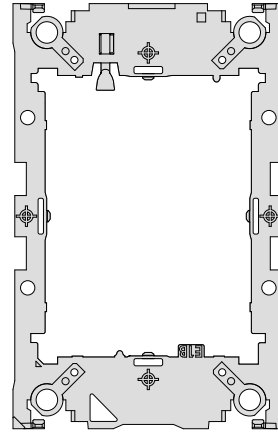
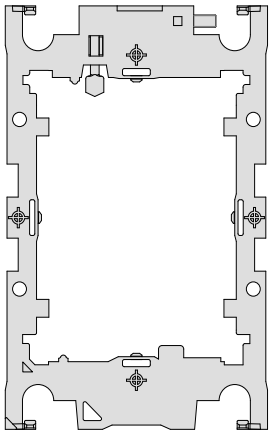

Carrier Bottom View

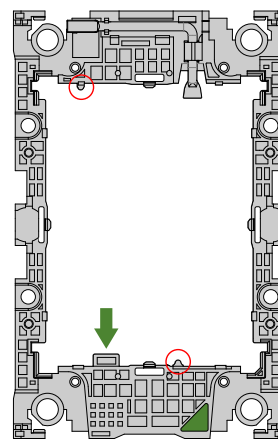
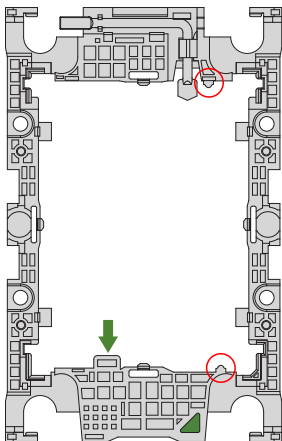

➔ = Cutout ▲ = Pin 1 ○ = CPU Key

3. Heatsink

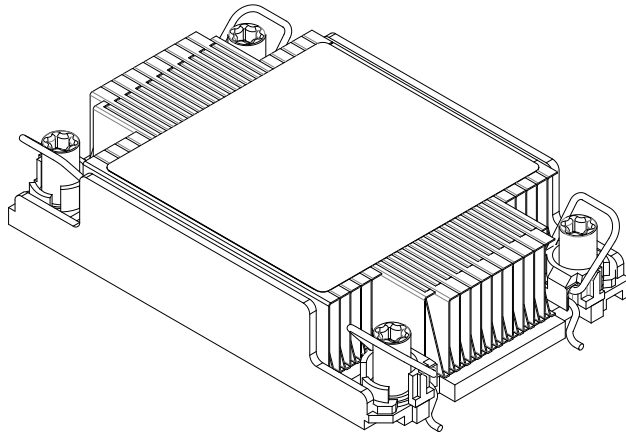

1U Heatsink

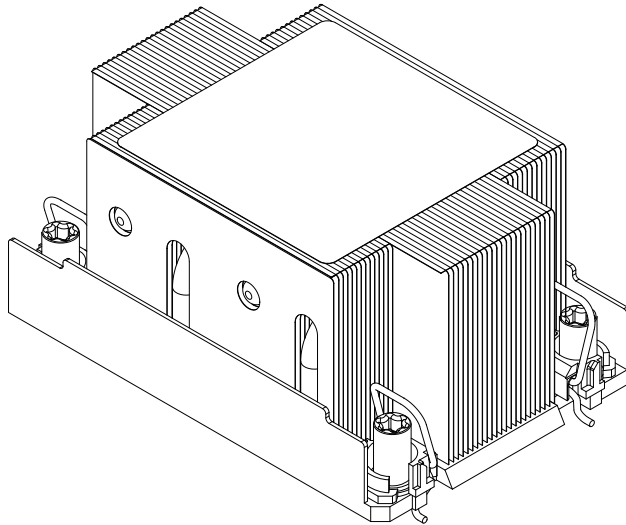

2U Heatsink

Note: Exercise extreme care when handling the heatsink. Pay attention to the edges of heatsink fins, which can be sharp! To avoid damaging the heatsink, please do not apply excessive force on the fins.

Overview of the CPU Socket

The CPU socket is protected by a plastic protective cover.

Plastic Protective Cover

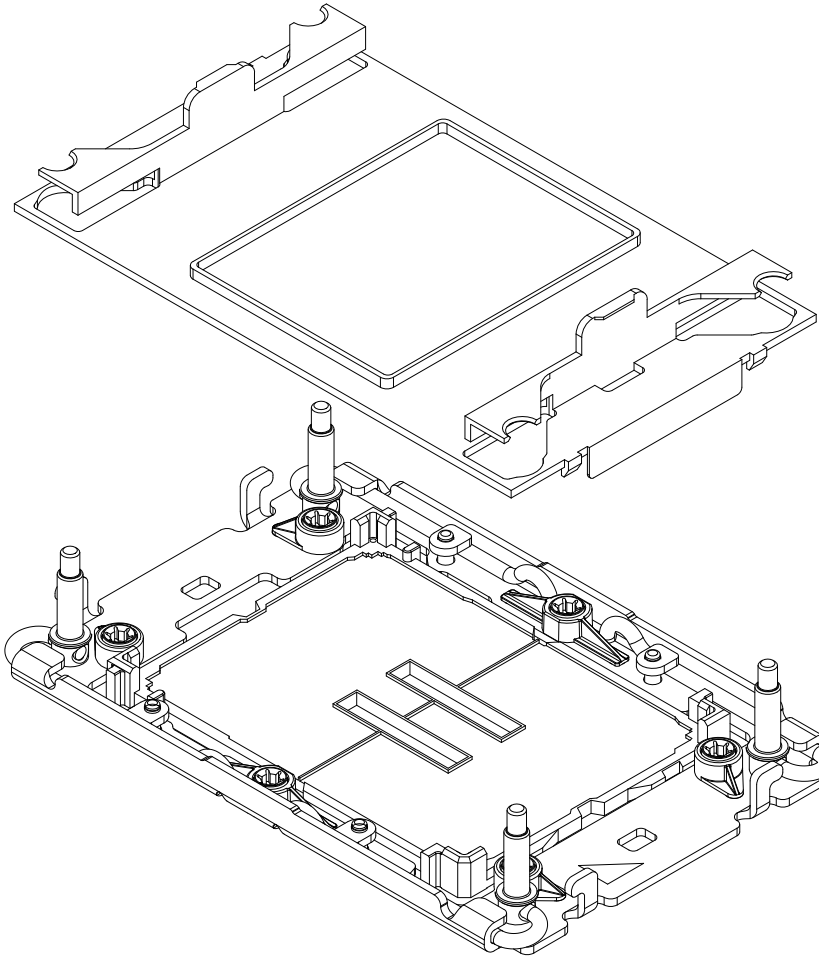

CPU Socket

Overview of the Processor Carrier Assembly

The processor carrier assembly contains a 5th/4th Gen. Intel Xeon Scalable processor and a processor carrier. Carefully follow the instructions given in the installation section to place a processor into the carrier to create a processor carrier assembly.

The processor carrier assembly includes a processor and a carrier as shown below.

1. The 5th/4th Gen. Intel Xeon Scalable Processor (Component Side)

Processor (2D)

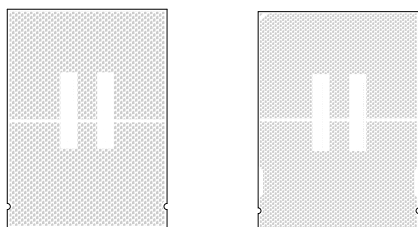

SP XCC

SP MCC

Processor (3D)

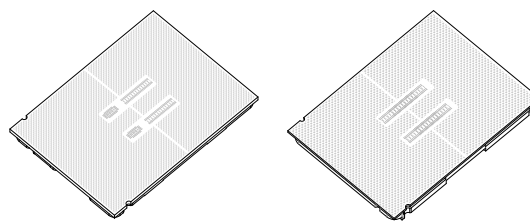

SP XCC

SP MCC

2. Processor Carrier (Top View)

Processor Carrier (2D)

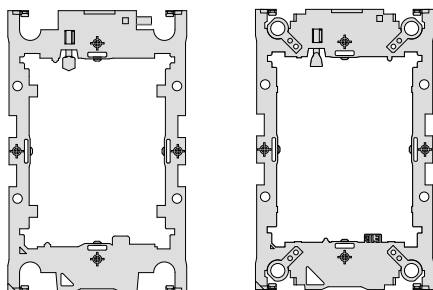

Carrier E1A

Carrier E1B

Processor Carrier (3D)

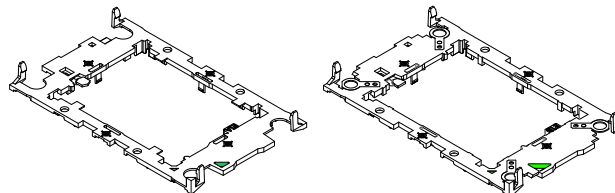

Carrier E1A

Carrier E1B



3. Processor Carrier Assembly (with processor seated inside the carrier)

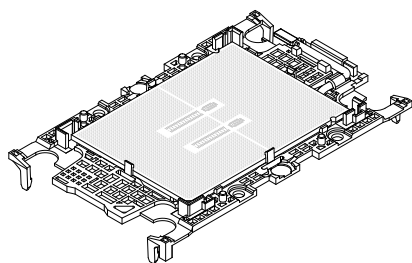

Carrier E1A with SP XCC Installed

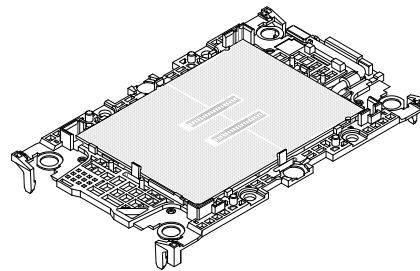

Carrier E1B with SP MCC Installed

Overview of the Processor Heatsink Module (PHM) with SP XCC and Carrier E1A

The Processor Heatsink Module (PHM) contains a heatsink, a processor carrier, and a 5th/4th Gen. Intel Xeon Scalable processor.

1. Heatsink

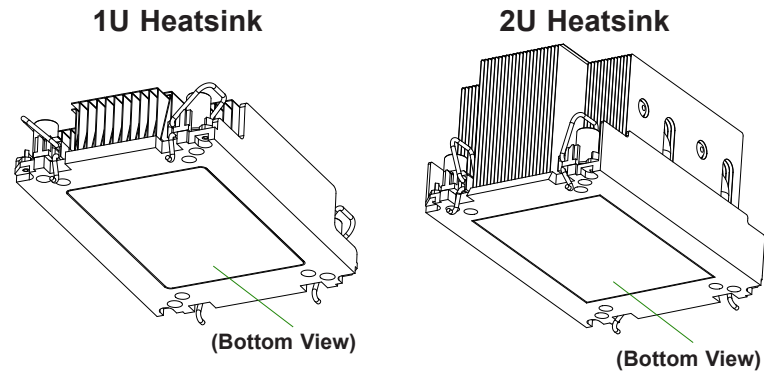

2. Processor Carrier E1A

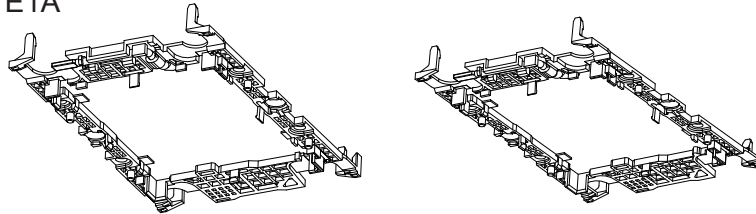

3. The 5th/4th Gen. Intel Xeon Scalable Processor (SP XCC)

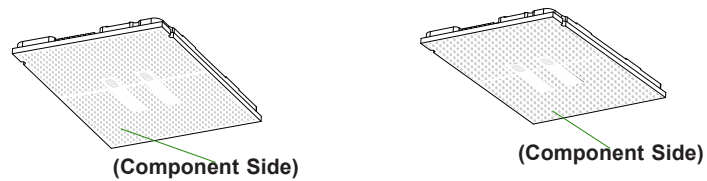

4. Processor Heatsink Module (PHM)

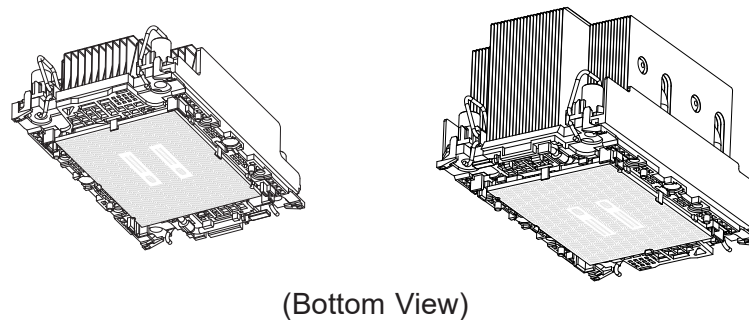

Overview of the Processor Heatsink Module (PHM) with SP MCC and Carrier E1B

The Processor Heatsink Module (PHM) contains a heatsink, a processor carrier, and a 5th/4th Gen. Intel Xeon Scalable processor.

1. Heatsink

1U Heatsink

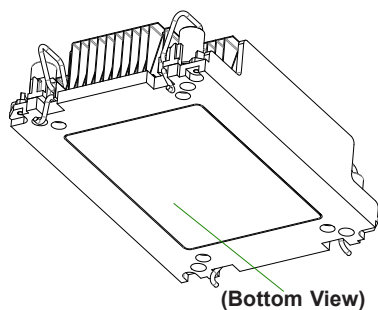

2U Heatsink

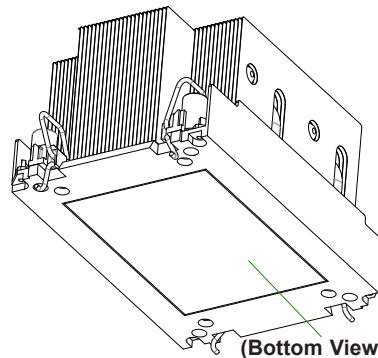

2. Processor Carrier E1B

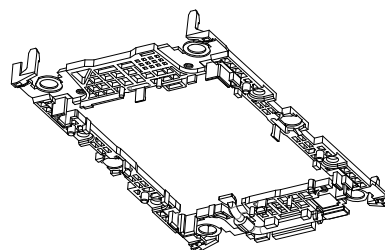
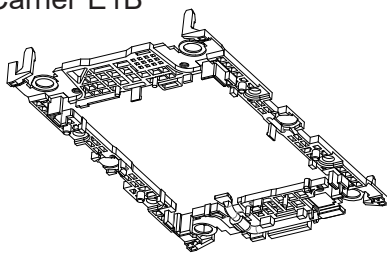

3. The 5th/4th Gen. Intel Xeon Scalable Processor (SP MCC)

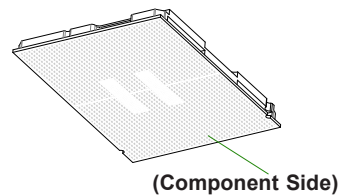
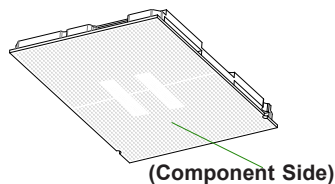

4. Processor Heatsink Module (PHM)

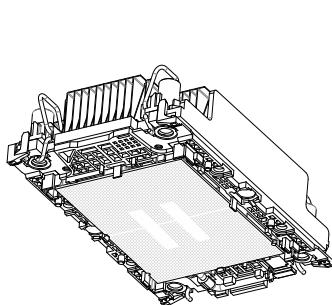

(Bottom View)

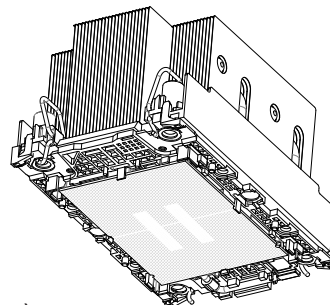

Creating the Processor Carrier Assembly

The processor carrier assembly contains a 5th/4th Gen. Intel Xeon Scalable processor and a processor carrier.

To create the processor carrier assembly, please follow the steps below:

Note: Before installation, be sure to follow the instructions given on pages 1 and 2 of this chapter to properly prepare for installation.

1. Hold the processor with the component side (including the gold contacts) facing down. Locate the small, gold triangle at the corner of the processor and the corresponding hollowed triangle on the processor carrier as shown below. Please note that the triangle indicates the location of Pin 1.

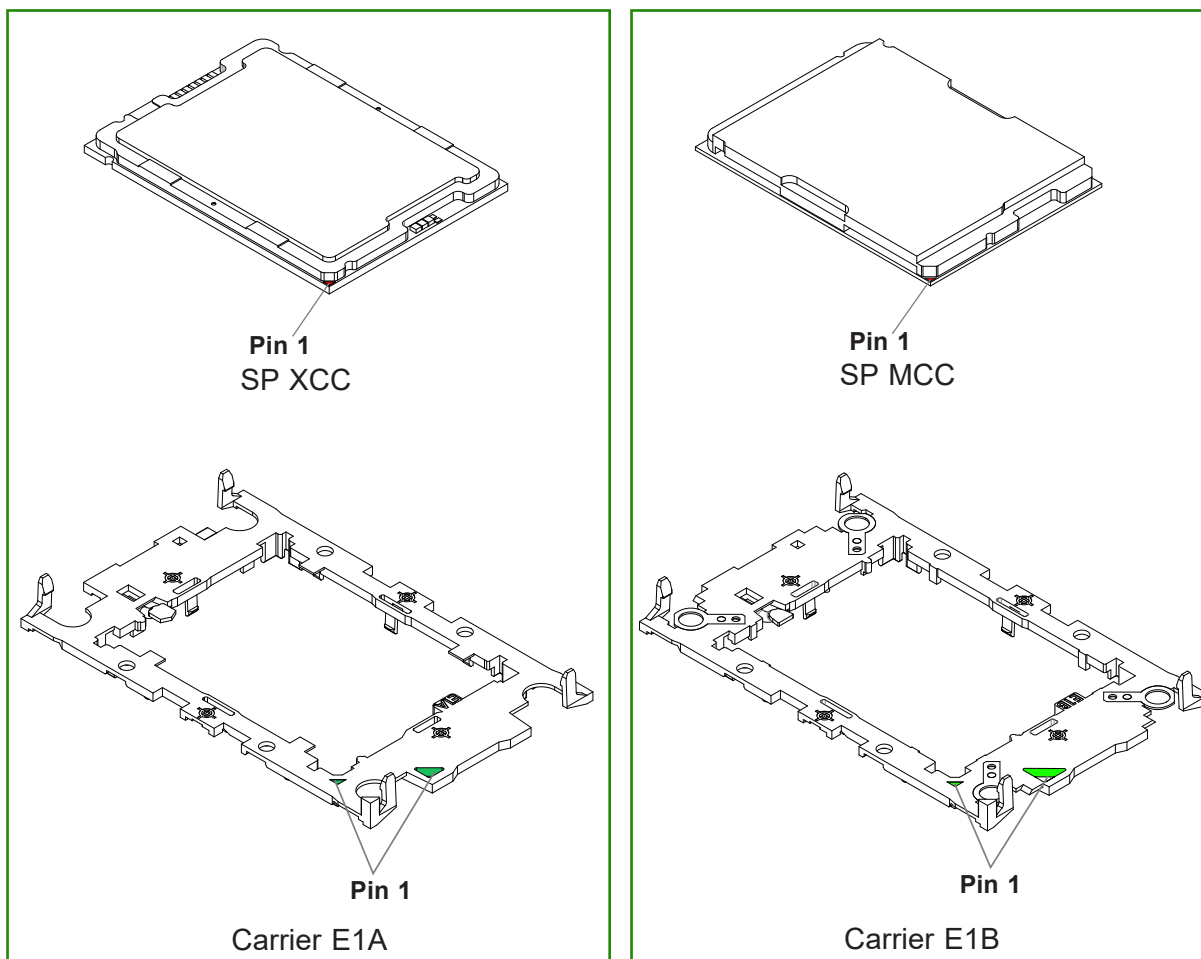

Processor with Matching Carrier

2. First, turn over the processor carrier and locate Pin 1 on the CPU and Pin 1 on the carrier. Then, turn the processor over with component side (including the gold contacts) facing up and locate CPU keys on the processor. Finally, locate the CPU keys and four latches on the carrier as shown below.

SP XCC

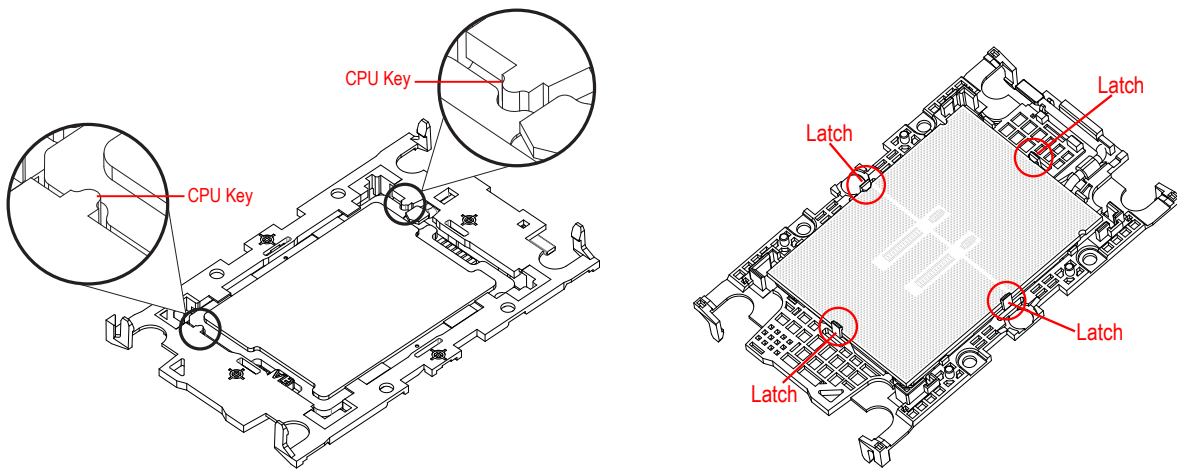

SP MCC

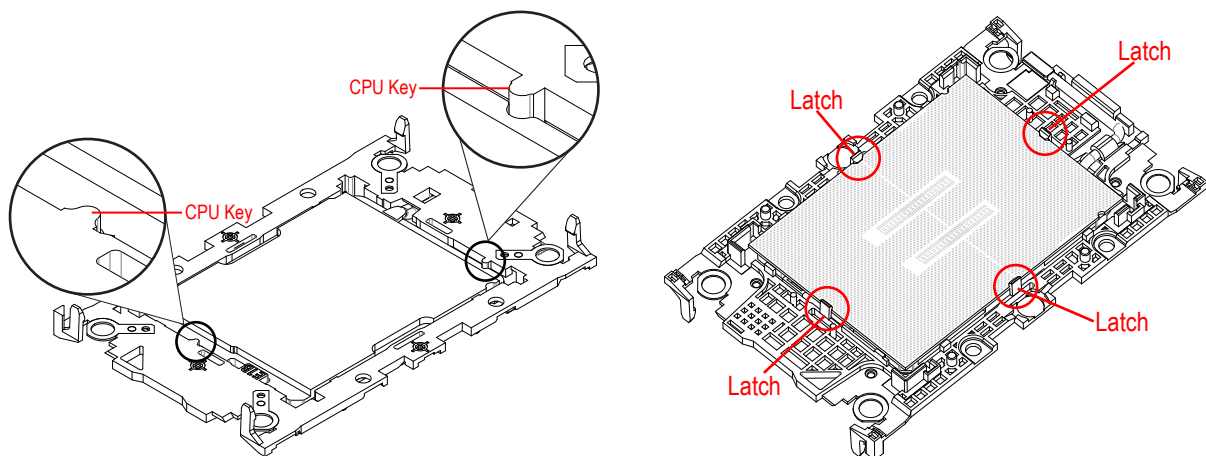

Carrier with the Processor Installed

3. Locate the lever on the CPU socket and press it down as shown below.

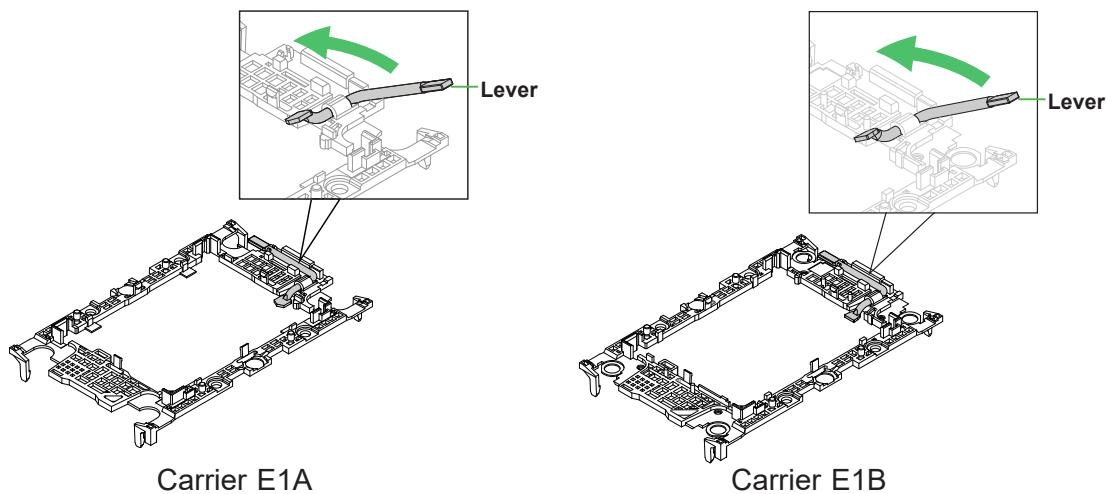

4. Using Pin 1 as a guide, carefully align the CPU keys (marked A and B) on the processor against the CPU keys on the carrier (marked a and b) as shown below.
5. Once they are properly aligned, carefully insert the CPU into the carrier, making sure that the CPU is properly secured by latches (marked 1, 2, 3, and 4).

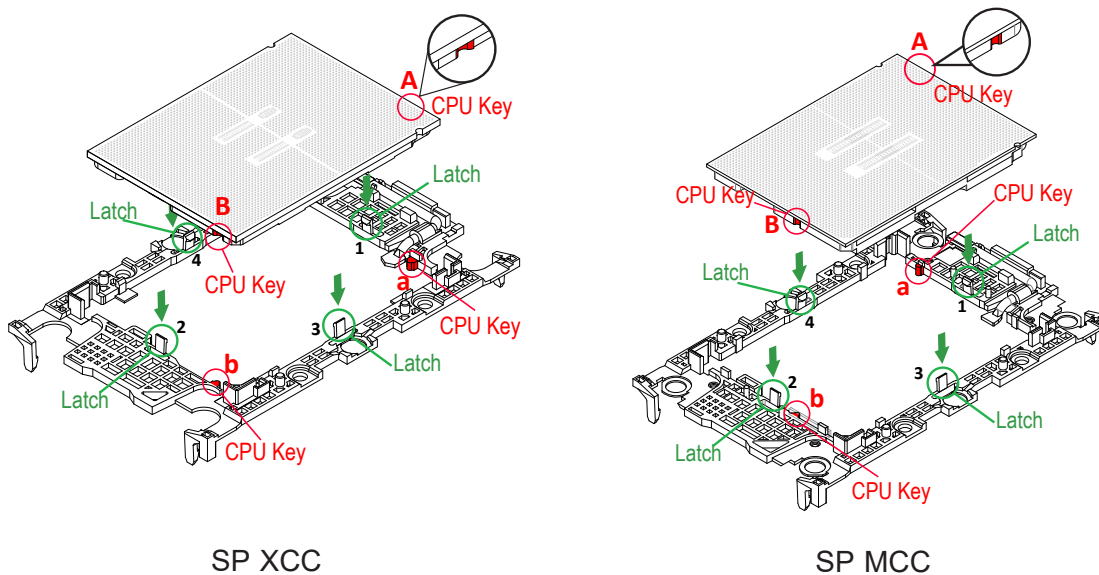

6. After the processor is placed inside the carrier, examine the four sides of the processor, making sure that the processor is properly seated on the carrier.

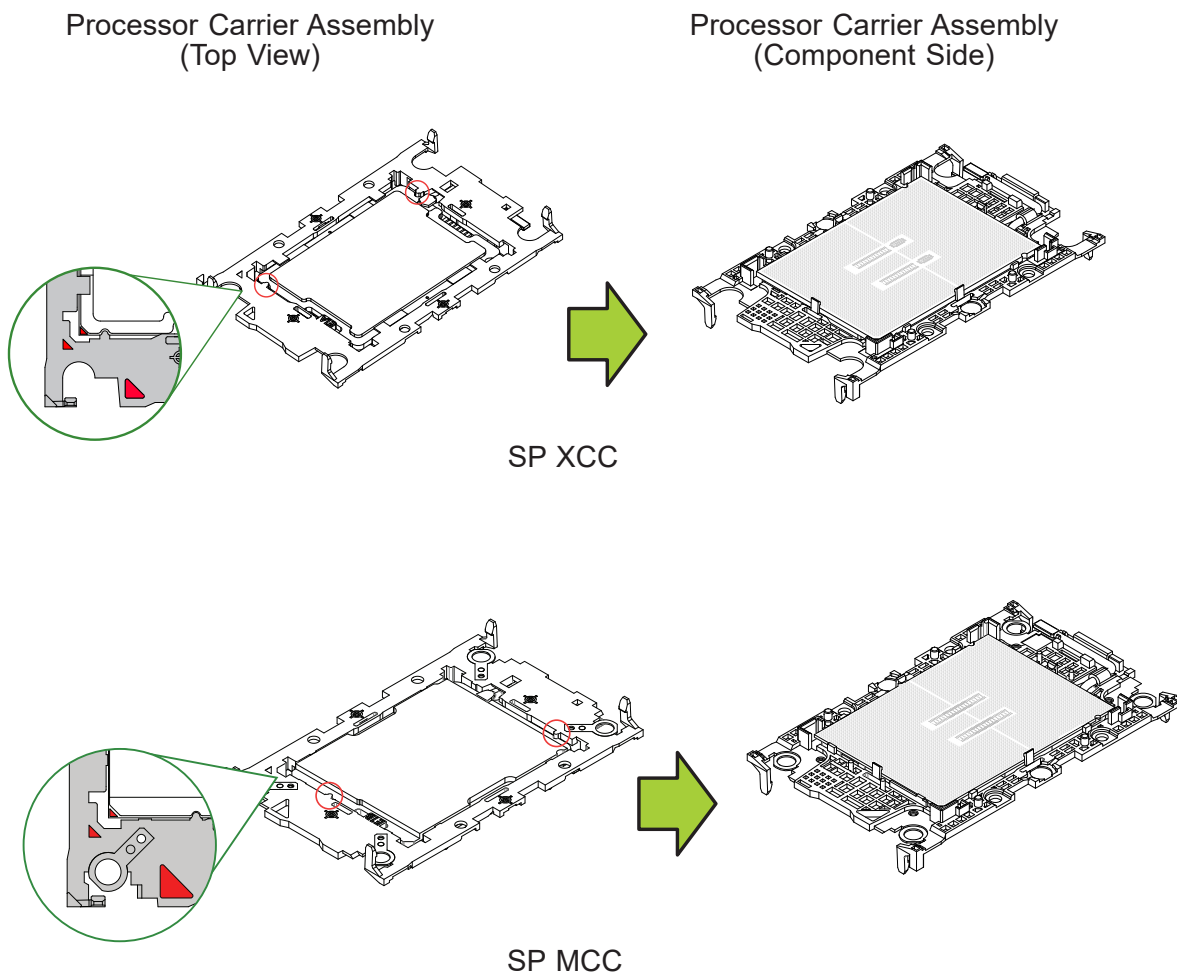

Creating the PHM

After creating the processor carrier assembly, please follow the instructions below to mount the processor carrier into the heatsink to form the PHM.

Note: If this is a new heatsink, the thermal grease has been pre-applied on the underside. Otherwise, apply the proper amount of thermal grease.

1. Turn the heatsink over with the thermal grease, which is on the bottom side of the heatsink, facing up. Pay attention to the two triangle cutouts (marked A and B) located at the diagonal corners of the heatsink as shown below.
2. Hold the processor carrier assembly with the component side facing up, and locate the triangle on the CPU and the triangle on the carrier. (Triangle indicates Pin 1.)
3. Using Pin 1 as a guide, turn the processor carrier assembly over with the gold contacts facing up. Locate the triangle cutout (marked A) on the heatsink and the corner (marked a) on the processor carrier assembly.
4. Align the corner (marked a) on the processor carrier assembly against the triangle cutout (marked A) on the heatsink, and align the corners (marked b, c, d) on the processor carrier assembly against the corners (marked B, C, D) on the heatsink.
5. Once they are properly aligned, place the corners (marked a, b, c, d) on the processor carrier assembly into the corners of the heatsink (marked A, B, C, D), making sure that all plastic clips are properly attached to the heatsink.

Creating the PHM (1U Heatsink)

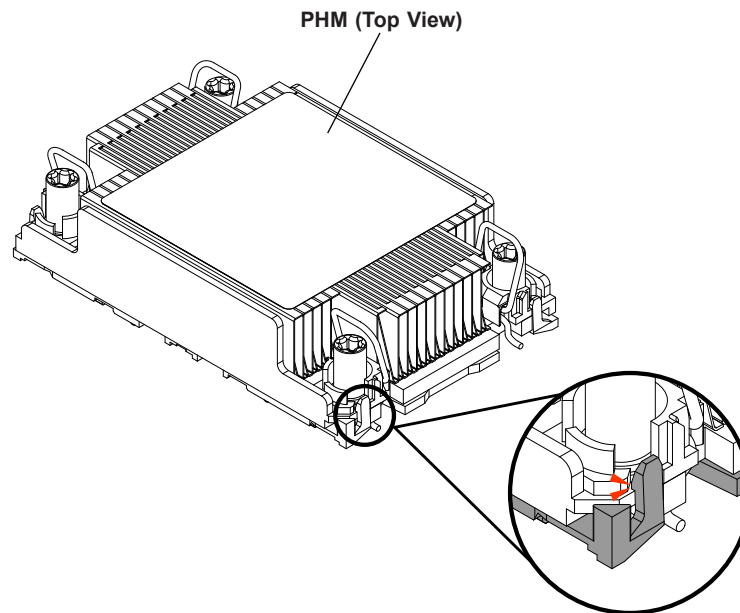
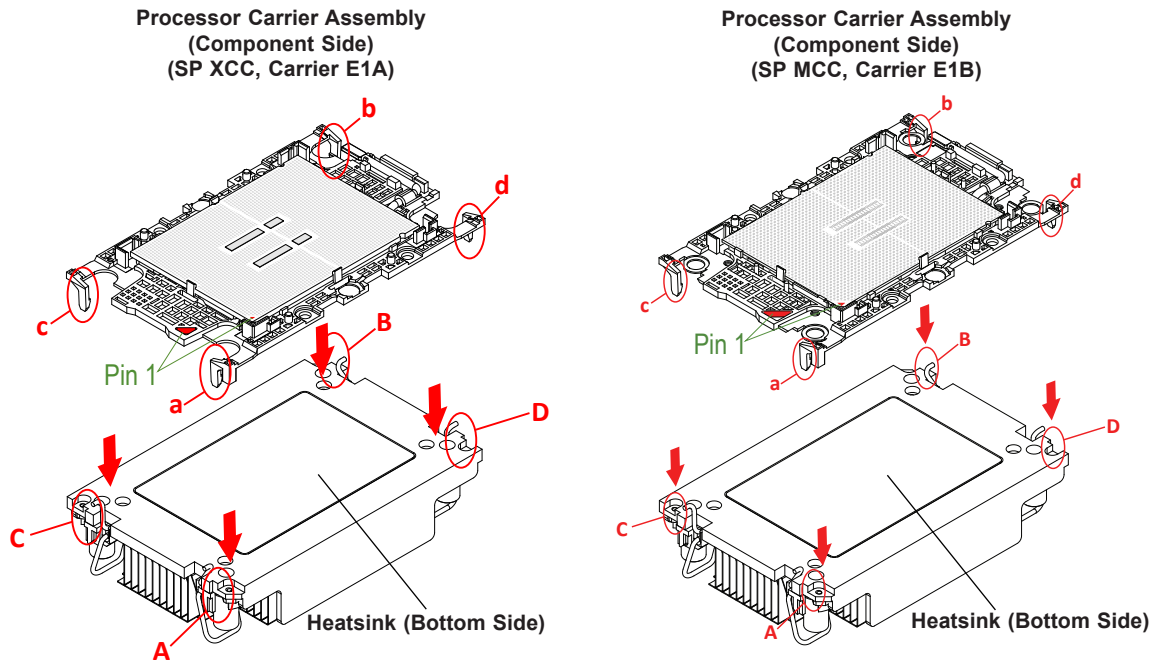

Creating the PHM (2U Heatsink)

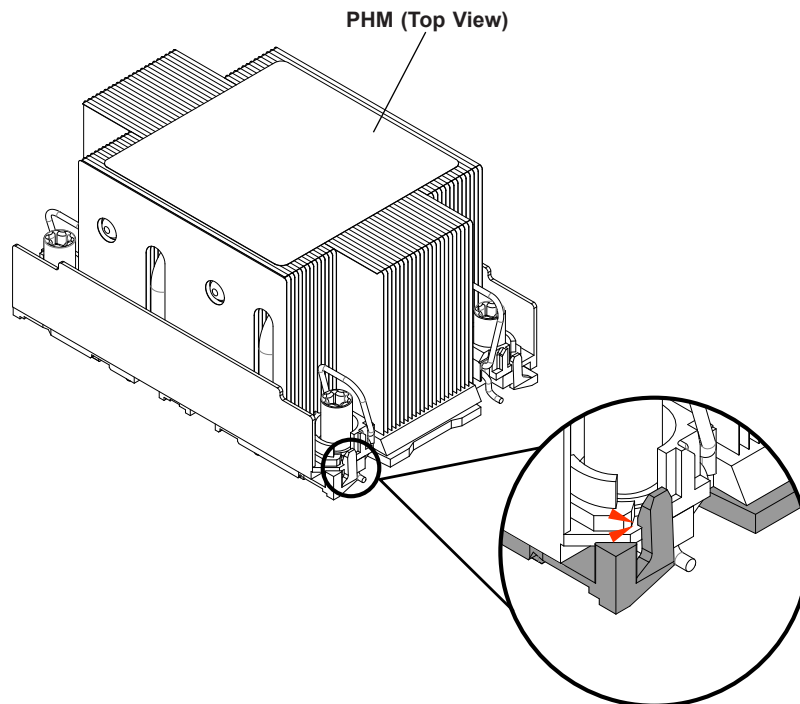
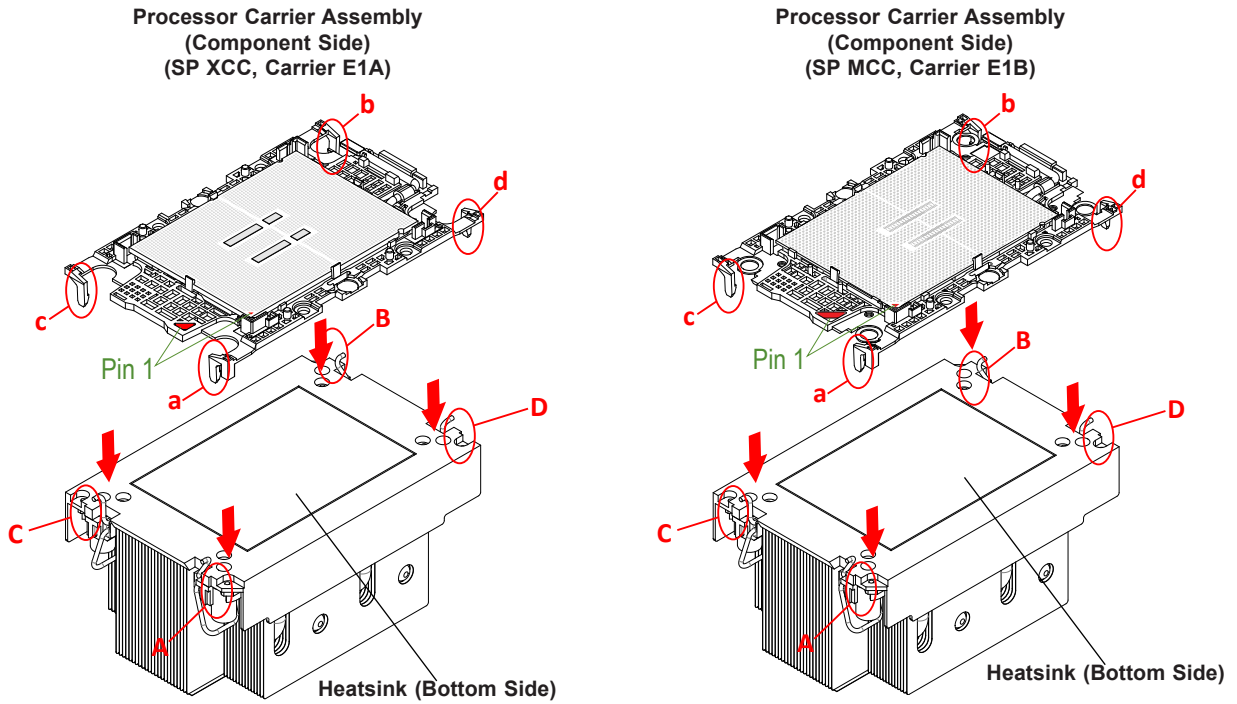

PHM (2U Heatsink)

Preparing the CPU Socket for Installation

This motherboard comes with a plastic protective cover installed on the CPU socket. Remove it from the socket by following the instructions below.

1. Press the tabs inward.

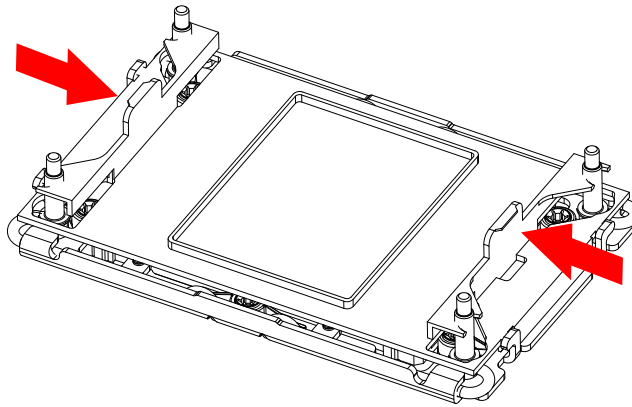

2. Pull up the protective cover from the socket.

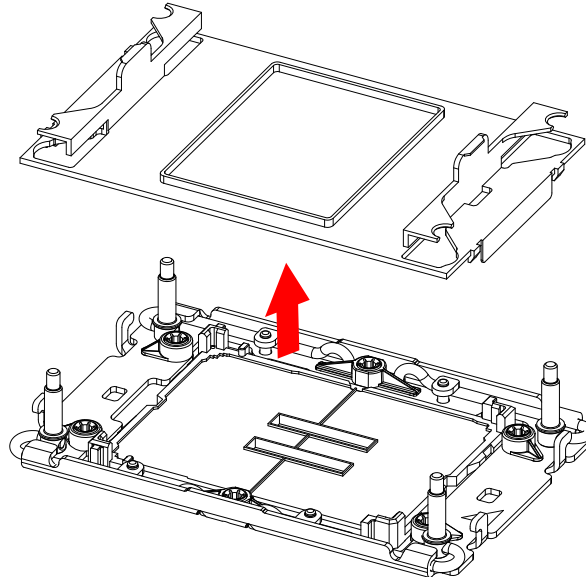

Preparing to Install the PHM into the CPU Socket

After assembling the Processor Heatsink Module (PHM), you are ready to install it into the CPU socket. To ensure the proper installation, please follow the procedures below.

1. Locate four threaded fasteners (marked a, b, c, d) on the CPU socket.

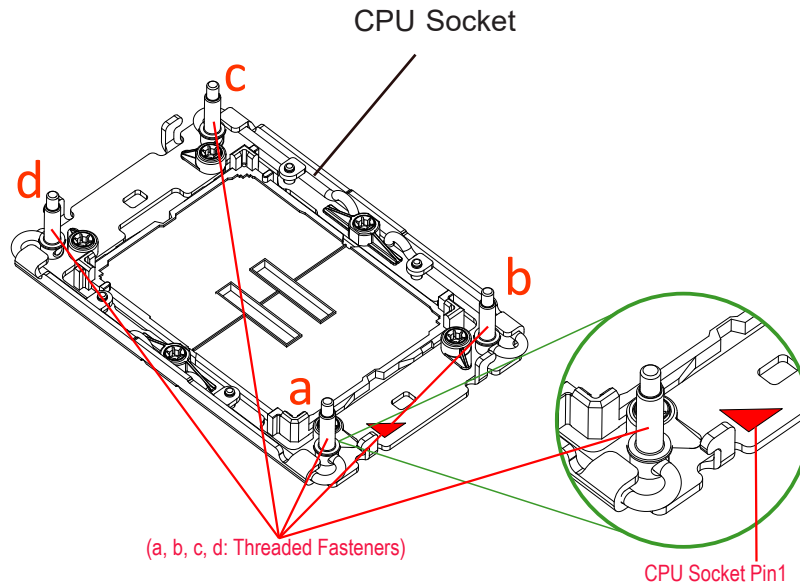

2. Locate four peek nuts (marked A, B, C, D) and four rotating wires (marked 1, 2, 3, 4) on the heatsink as shown below.

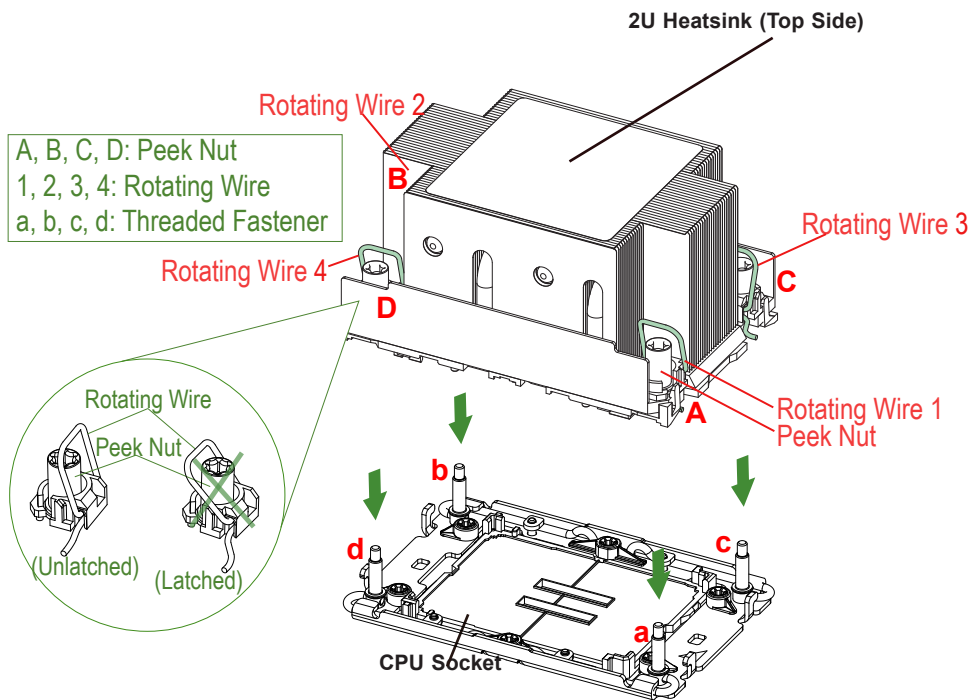
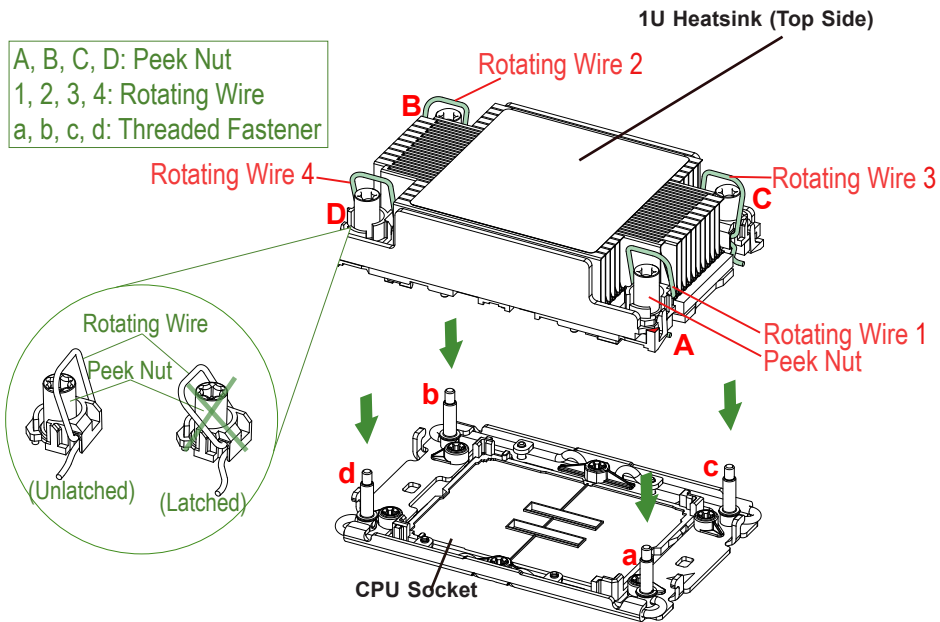

3. Check the rotating wires (marked 1, 2, 3, 4) to make sure that they are at unlatched positions as shown below before installing the PHM into the CPU socket.

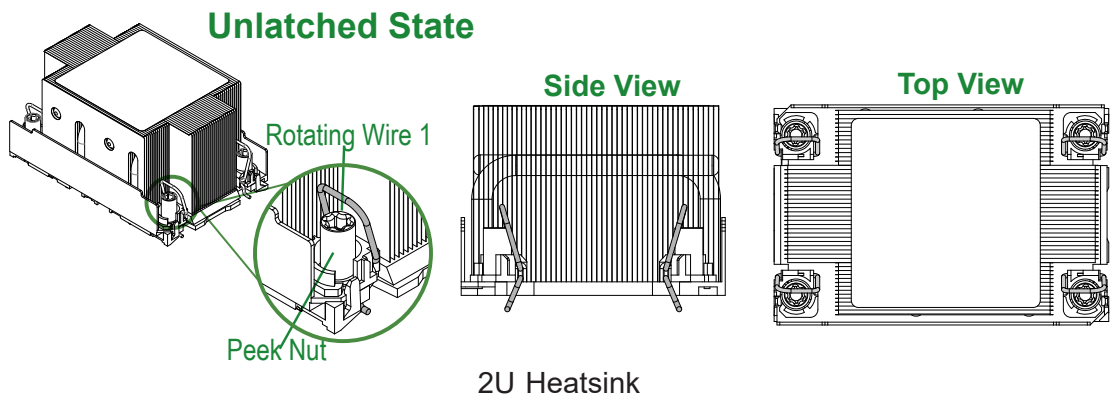
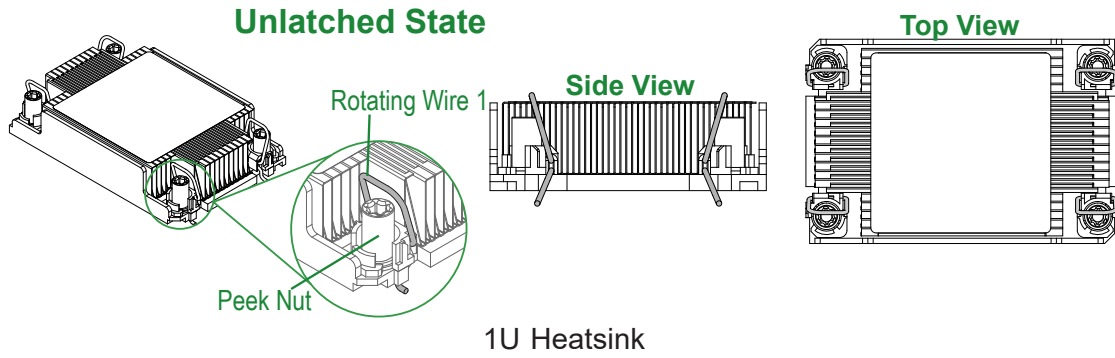

Installing the PHM into the CPU Socket

1. Align peek nut (marked A) on the heatsink against threaded fastener (marked a) on the CPU socket. Then align peek nuts (marked B, C, D) on the heatsink against threaded fasteners (marked b, c, d) on the CPU socket, making sure that all peek nuts on the heatsink are properly aligned with the correspondent threaded fasteners on the CPU socket.
2. Once they are aligned, gently place the heatsink on top of the CPU socket, making sure that each peek nut is properly attached to its corresponding threaded fastener.

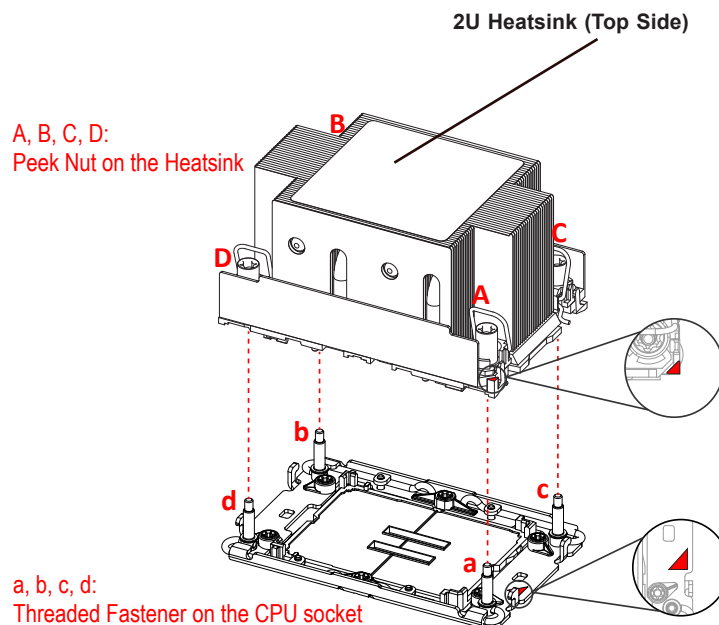
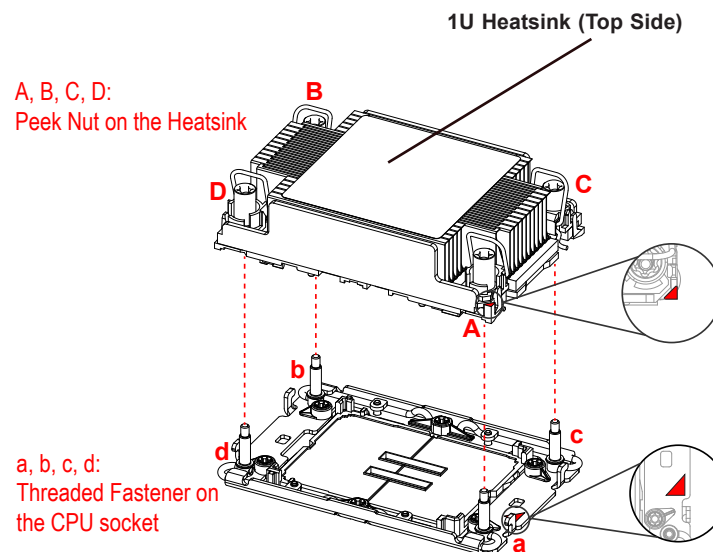

3. Press all four rotating wires outwards and make sure that the heatsink is securely latched onto the CPU socket.

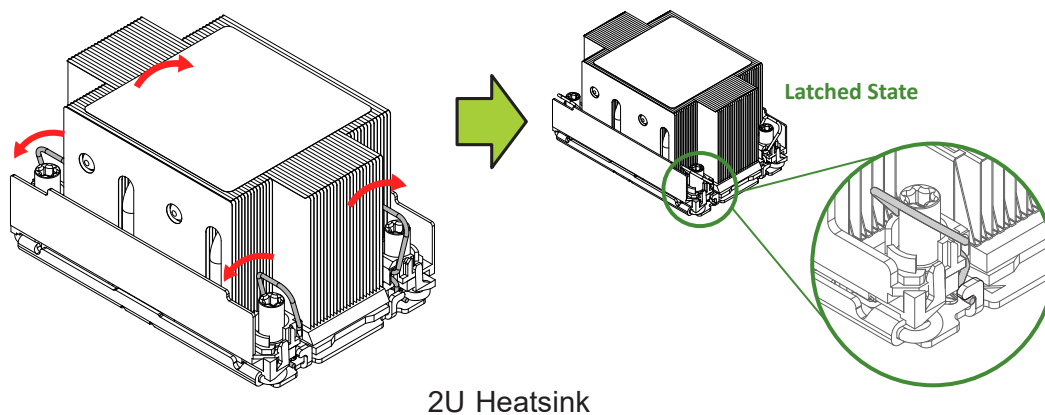
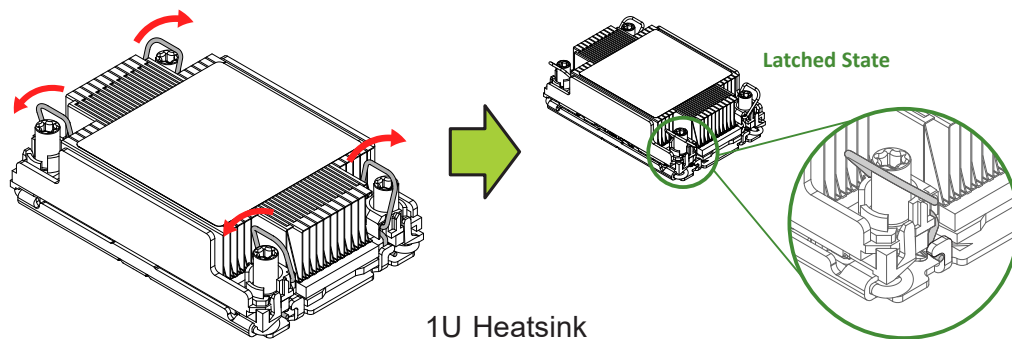

4. With a T30 bit torque driver set to a force of 8.0 in-lbf (0.904 N-m), tighten all peek nuts in the sequence of A, B, C, and D with even pressure. To avoid damaging the processor or socket, do not use excessive force when tightening the peek nuts. (For best durability, 8.0 in-lbf torque is recommended.)
5. Examine all corners of the heatsink to ensure that the PHM is firmly attached to the CPU socket.

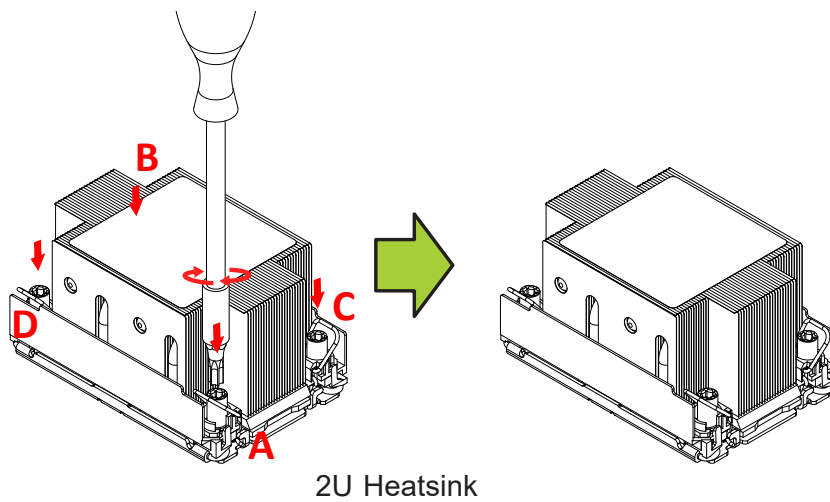
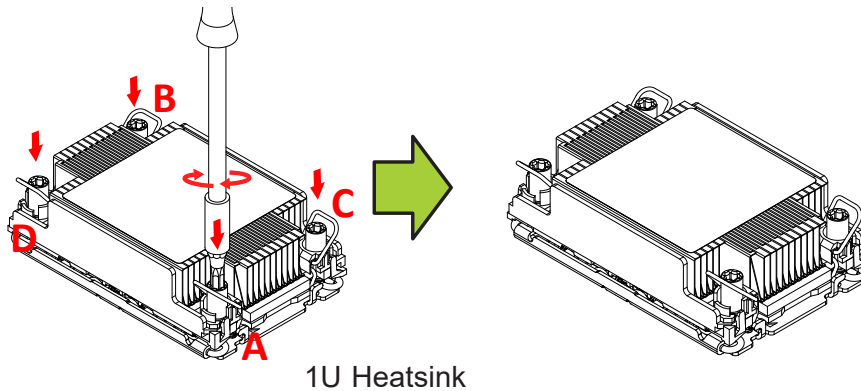

Removing the PHM from the CPU Socket

Before removing the PHM from the motherboard, be sure to shut down the system and unplug the power cables from the power supply. Then follow the steps below.

1. Use a T30 torque driver to loosen the four peek nuts on the heatsink in the sequence of A, B, C, and D.

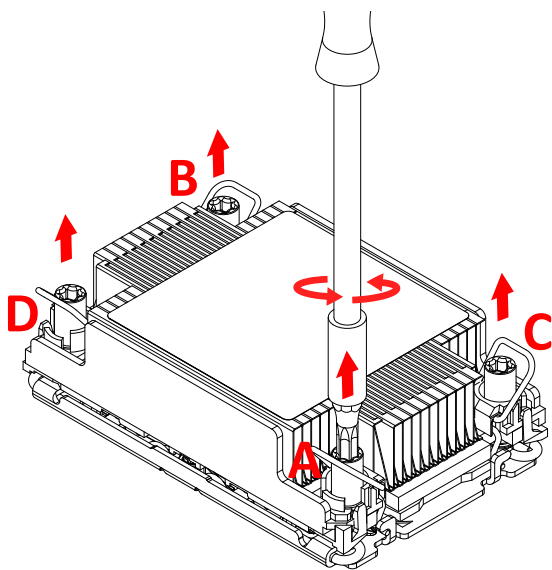

1U Heatsink

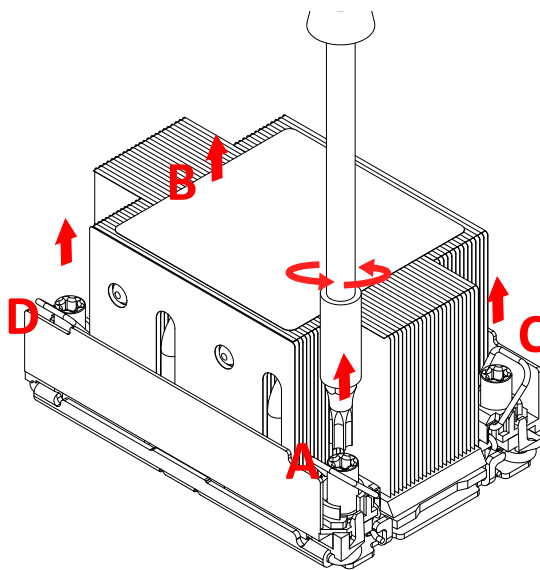

2U Heatsink

2. Once the peek nuts are loosened from the CPU socket, press the rotating wires inwards to unlatch the PHM from the socket as shown below.

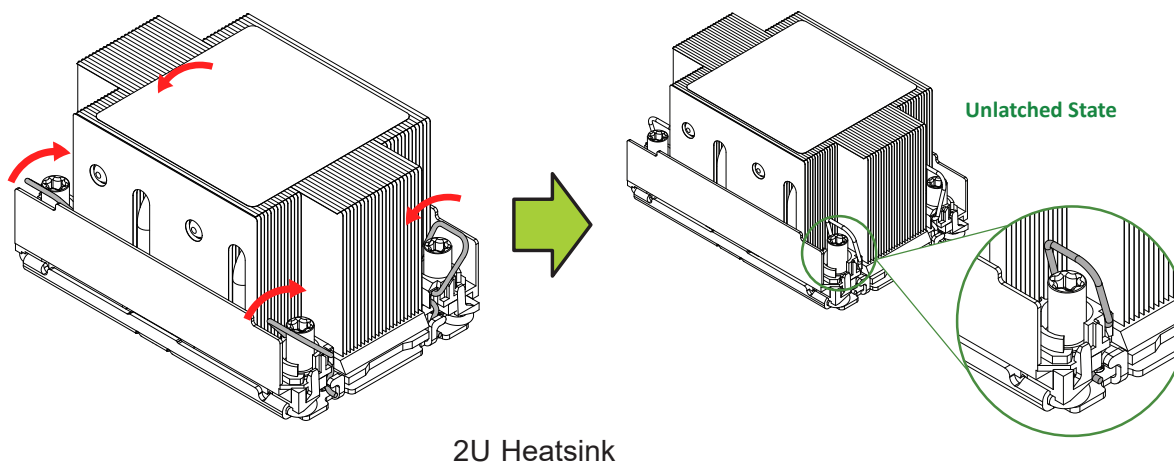
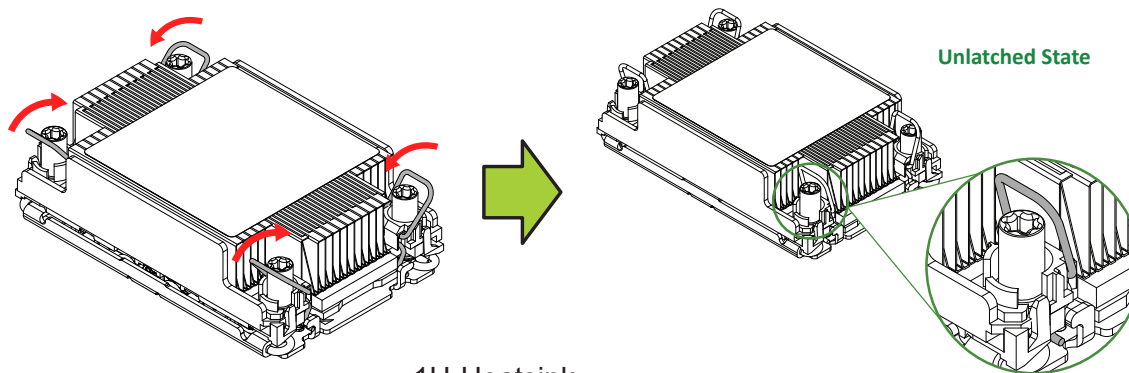

3. Gently pull the PHM upwards to remove it from the CPU socket.

1U Heatsink

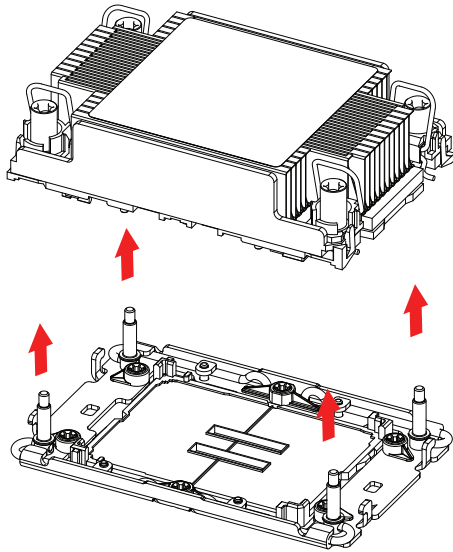

2U Heatsink

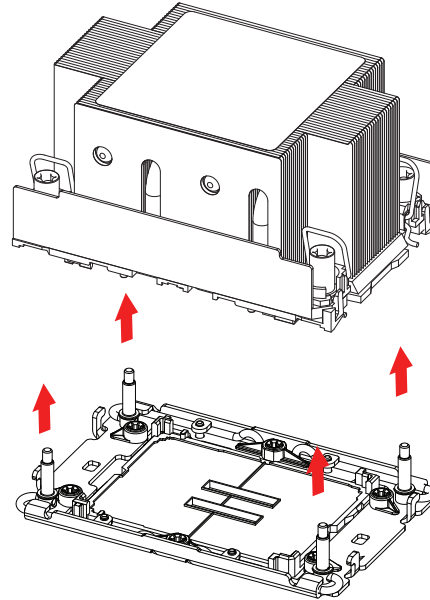

Removing the Processor Carrier Assembly from the PHM

To remove the processor carrier assembly from the PHM, please follow the steps below.

1. Detach the four plastic clips (marked a, b, c, d) on the processor carrier assembly from the four corners of the heatsink (marked A, B, C, D) as shown below.

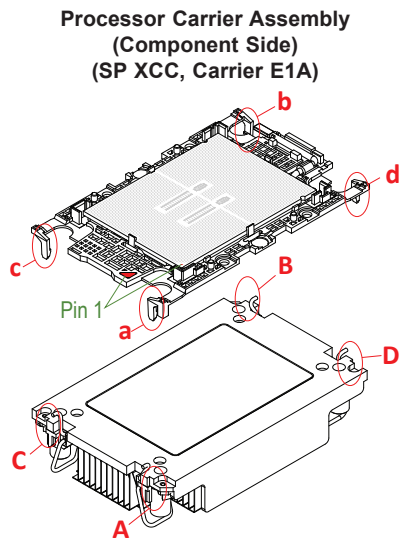

1U Heatsink (Bottom View)

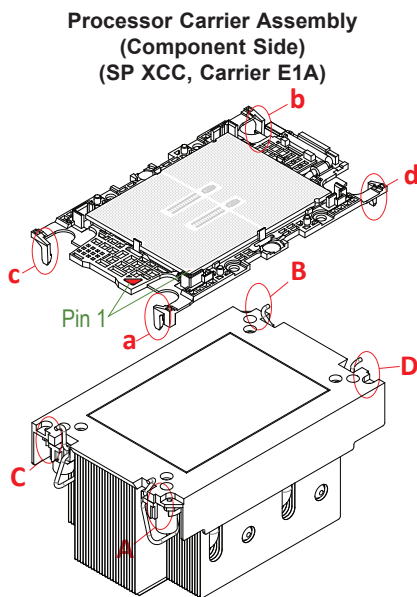
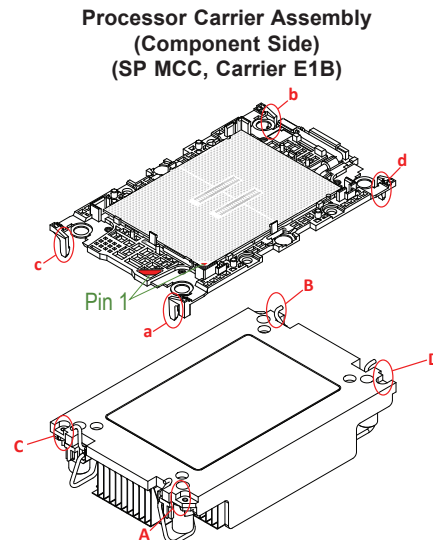

2U Heatsink (Bottom View)

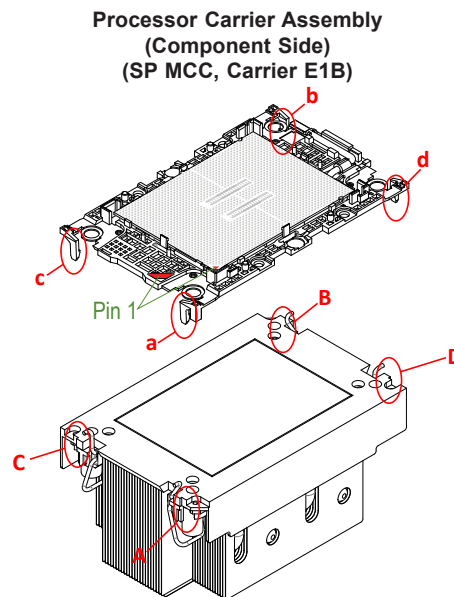

2. When all plastic clips are detached from the heatsink, remove the processor carrier assembly from the heatsink.

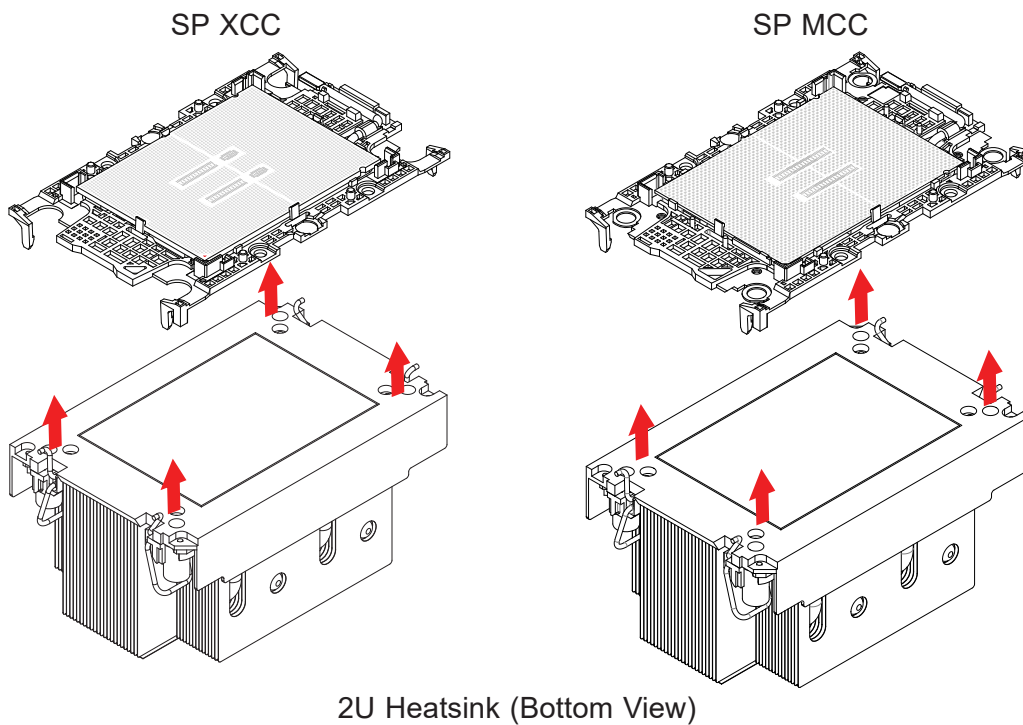
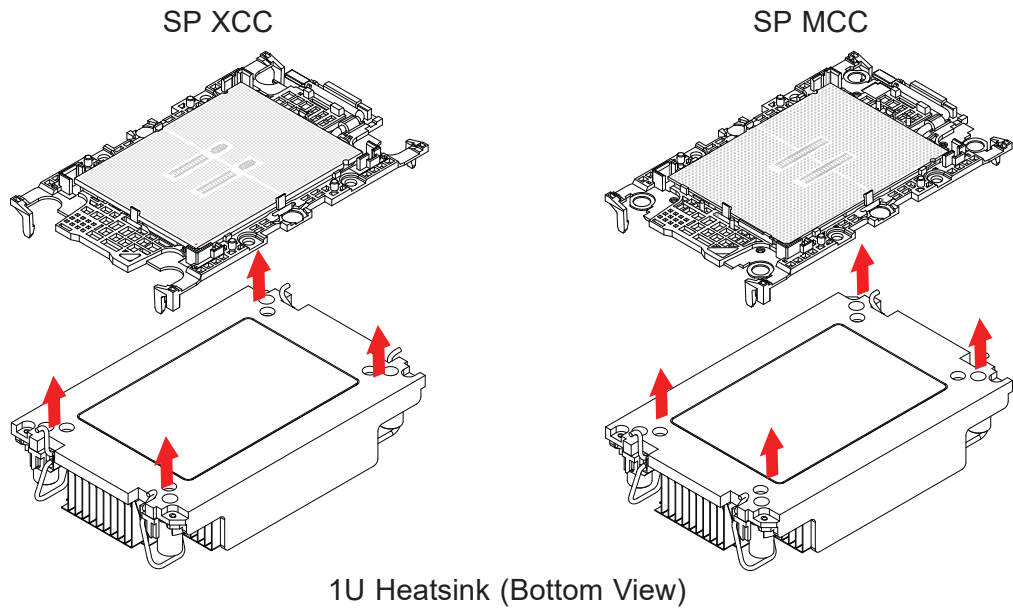

Removing the Processor from the Processor Carrier Assembly

Once you have removed the processor carrier assembly from the PHM, you are ready to remove the processor from the processor carrier by following the steps below.

1. Unlock the lever from its locked position and push the lever upwards to disengage the processor from the processor carrier as shown in the drawings on the right below.

Processor Carrier Assembly (SP XCC, Carrier E1A)

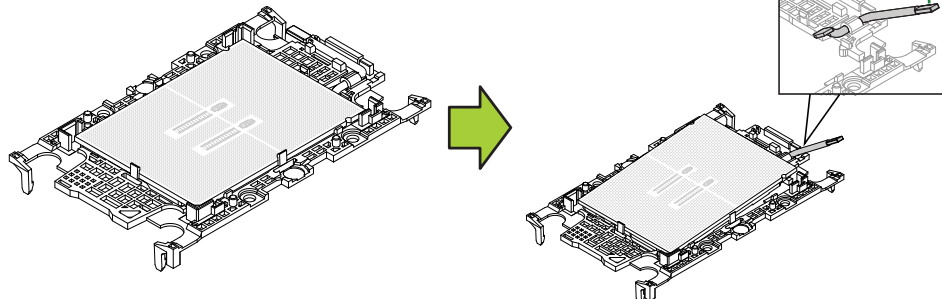

Processor Carrier Assembly (SP MCC, Carrier E1B)

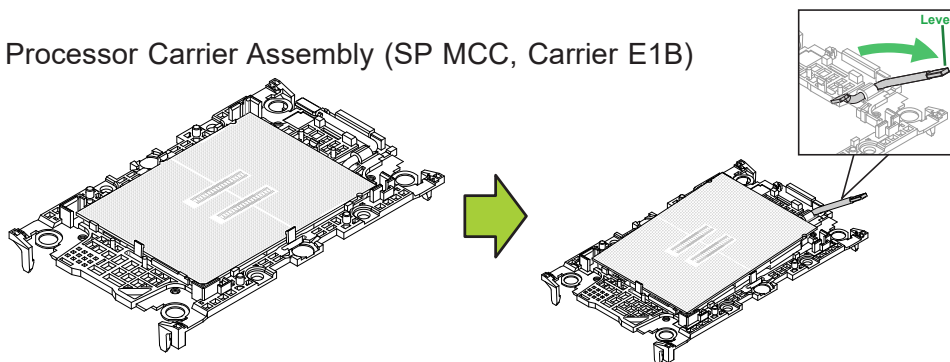

2. Once the processor is loosened from the carrier, carefully remove the processor from the processor carrier.

Note: Please handle the processor with care to avoid damaging the processor and its pins.

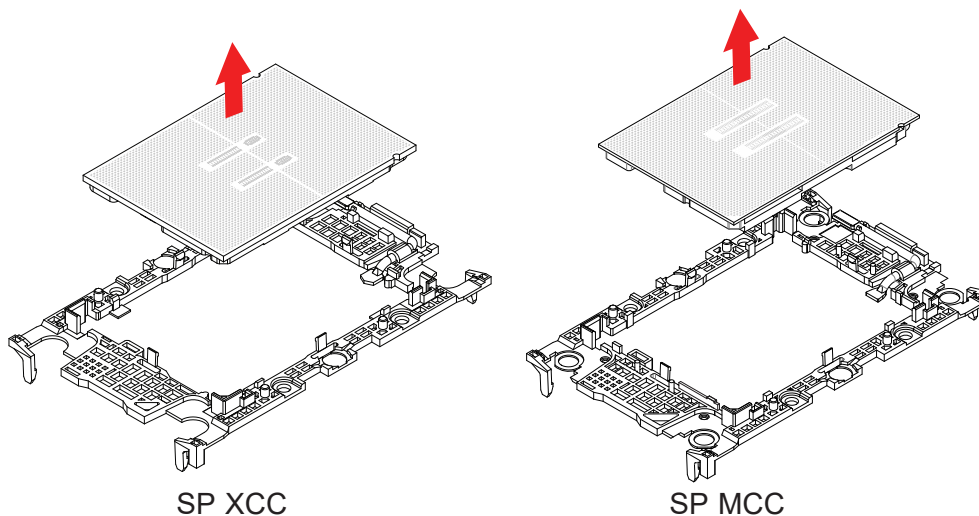

3.4 Memory Support and Installation

Note: Check the Supermicro website for recommended memory modules.

Important: Exercise extreme care when installing or removing memory modules to prevent any possible damage.

Memory Support

This motherboard supports up to 8 TB memory capacity with 32 DIMMs of 256 GB 3DS RDIMM/RDIMM DDR5 ECC memory.

Note: Memory speed and capacity support depends on the processors used in the system.

DDR5 Memory Support for the 5th Gen. Intel Xeon Scalable Processors

DDR5 Memory Support for the 5th Gen. Intel Xeon Scalable Processors					
Type	Ranks Per DIMM & Data Width (Stack)	DIMM Capacity (GB)		Speed (MT/s); Voltage (V); DIMM Per Channel (DPC)	
		16 Gb (DRAM Density)	24 Gb (DRAM Density)	1DPC ^{Note 1}	2DPC
RDIMM	SRx8 (RC D)	16 GB	24 GB ^{Note 2}	5600	4400
	SRx4 (RC C)	32 GB	48 GB ^{Note 2}		
	SRx4 (RC F) 9x4	32 GB	48 GB ^{Note 2}		
	DRx8 (RC E)	32 GB	48 GB ^{Note 2}		
	DRx4 (RC A)	64 GB	96 GB		
	DRx4 (RC B) 9x4	64 GB	96 GB		
RDIMM 3DS	(4R/8R) x4 (RC A)	2 H-128 GB 4 H-256 GB	N/A		
LRDIMM/LRDIMM-3DS	N/A	N/A	N/A	Not Supported	Not Supported

Note 1: 1DPC applies to 1 SPC (Sockets Per Channel) or 2 SPC implementation.

Note 2: The 24 Gb 2DPC configuration with 24 GB and 48 GB DIMMs is NOT recommended.

DDR5 Memory Support for the 4th Gen. Intel Xeon Scalable Processors

DDR5 Memory Support for the 4th Gen. Intel Xeon Scalable Processors				
Type	Ranks Per DIMM & Data Width (Stack)	DIMM Capacity (GB)	Speed (MT/s); Voltage (V); DIMM Per Channel (DPC)	
			1DPC ^{Note}	2DPC
		16 Gb (DRAM Density)	1.1 V	
RDIMM	SRx8 (RC D)	16 GB	4800	4400
	SRx4 (RC C)	32 GB		
	SRx4 (RC F) 9x4	32 GB		
	DRx8 (RC E)	32 GB		
	DRx4 (RC A)	64 GB		
	DRx4 (RC B) 9x4	64 GB		
RDIMM 3DS	(4R/8R) x4 (RC A)	2 H-128 GB 4 H-256 GB		
LRDIMM/LRDIMM-3DS	N/A	N/A	Not Supported	Not Supported

Note: 1DPC applies to 1 SPC (Sockets Per Channel) or 2 SPC implementation.

Compatible and Incompatible Type in a Channel and a System			
DIMM Type	RDIMM	RDIMM 3DS	9x4 RDIMM
RDIMM	Compatible	Incompatible	Incompatible
RDIMM 3DS	Incompatible	Compatible	Incompatible
9x4 RDIMM	Incompatible	Incompatible	Compatible

Memory Population for the X13DSF-A Motherboard

DDR5 Memory Population Table for the X13DSF-A Motherboard (with 32 DIMM Slots)	
1 CPU:	Memory Population Sequence
1 CPU & 1 DIMM	P1-DIMMA1 or P1-DIMME1 or P1-DIMMB1 or P1-DIMMF1
1 CPU & 2 DIMMs	P1-DIMMA1/P1-DIMMG1 or P1-DIMMC1/P1-DIMME1
1 CPU & 4 DIMMs	P1-DIMMA1/P1-DIMMC1/P1-DIMME1/P1-DIMMG1
1 CPU & 6 DIMM	P1-DIMMA1/P1-DIMMC1/P1-DIMMD1/P1-DIMME1/P1-DIMMF1/P1-DIMMG1 or P1-DIMMA1/P1-DIMMB1/P1-DIMMC1/P1-DIMME1/P1-DIMMG1/P1-DIMMH1 or P1-DIMMB1/P1-DIMMC1/P1-DIMMD1/P1-DIMME1/P1-DIMMF1/P1-DIMMH1 or P1-DIMMA1/P1-DIMMB1/P1-DIMMD1/P1-DIMMF1/P1-DIMMG1/P1-DIMMH1
1 CPU & 8 DIMMs	P1-DIMMA1/P1-DIMMB1/P1-DIMMC1/P1-DIMMD1/P1-DIMME1/P1-DIMMF1/P1-DIMMG1/P1-DIMMH1
1 CPU & 12 DIMMs	P1-DIMMA1/P1-DIMMA2/P1-DIMMB1/P1-DIMMC1/P1-DIMMC2/P1-DIMMD1/P1-DIMME1/P1-DIMME2/P1-DIMMF1/P1-DIMMG1/P1-DIMMG2/P1-DIMMH1 or P1-DIMMA1/P1-DIMMB1/P1-DIMMB2/P1-DIMMC1/P1-DIMMD1/P1-DIMMD2/P1-DIMME1/P1-DIMMF1/P1-DIMMF2/P1-DIMMG1/P1-DIMMH1/P1-DIMMH2
1 CPU & 16 DIMMs	P1-DIMMA1/P1-DIMMA2/P1-DIMMB1/P1-DIMMB2/P1-DIMMC1/P1-DIMMC2/P1-DIMMD1/P1-DIMMD2/P1-DIMME1/P1-DIMME2/P1-DIMMF1/P1-DIMMF2/P1-DIMMG1/P1-DIMMG2/P1-DIMMH1/P1-DIMMH2
2 CPUs: (Recommended)	Memory Population Sequence
2 CPUs & 2 DIMMs	CPU1: P1-DIMMA1, CPU2: P2-DIMMA1 or CPU1: P1-DIMME1, CPU2: P2-DIMME1 or CPU1: P1-DIMMB1, CPU2: P2-DIMMB1 or CPU1: P1-DIMMF1, CPU2: P2-DIMMF1
2 CPUs & 4 DIMMs	CPU1: P1-DIMMA1/P1-DIMMG1, CPU2: P2-DIMMA1/P2-DIMMG1 or CPU1: P1-DIMMC1/P1-DIMME1, CPU2: P2-DIMMC1/P2-DIMME1
2 CPUs & 8 DIMMs	CPU1: P1-DIMMA1/P1-DIMMC1/P1-DIMME1/P1-DIMMG1 CPU2: P2-DIMMA1/P2-DIMMC1/P2-DIMME1/P2-DIMMG1
2 CPUs & 10 DIMMs	CPU1: P1-DIMMA1/P1-DIMMC1/P1-DIMMD1/P1-DIMME1/P1-DIMMF1/P1-DIMMG1 CPU2: P2-DIMMA1/P2-DIMMC1/P2-DIMME1/P2-DIMMG1
2 CPUs & 12 DIMMs	CPU1: P1-DIMMA1/P1-DIMMC1/P1-DIMMD1/P1-DIMME1/P1-DIMMF1/P1-DIMMG1 CPU2: P2-DIMMA1/P2-DIMMC1/P2-DIMMD1/P2-DIMME1/P2-DIMMF1/P2-DIMMG1 or CPU1: P1-DIMMA1/P1-DIMMB1/P1-DIMMC1/P1-DIMME1/P1-DIMMG1/P1-DIMMH1 CPU2: P2-DIMMA1/P2-DIMMB1/P2-DIMMC1/P2-DIMME1/P2-DIMMG1/P2-DIMMH1 or CPU1: P1-DIMMB1/P1-DIMMC1/P1-DIMMD1/P1-DIMME1/P1-DIMMF1/P1-DIMMH1 CPU2: P2-DIMMB1/P2-DIMMC1/P2-DIMMD1/P2-DIMME1/P2-DIMMF1/P2-DIMMH1 or CPU1: P1-DIMMA1/P1-DIMMB1/P1-DIMMD1/P1-DIMMF1/P1-DIMMG1/P1-DIMMH1 CPU2: P2-DIMMA1/P2-DIMMB1/P2-DIMMD1/P2-DIMMF1/P2-DIMMG1/P2-DIMMH1
2 CPUs & 16 DIMMs	CPU1: P1-DIMMA1/P1-DIMMB1/P1-DIMMC1/P1-DIMMD1/P1-DIMME1/P1-DIMMF1/P1-DIMMG1/P1-DIMMH1 CPU2: P2-DIMMA1/P2-DIMMB1/P2-DIMMC1/P2-DIMMD1/P2-DIMME1/P2-DIMMF1/P2-DIMMG1/P2-DIMMH1
2 CPUs & 22 DIMMs	CPU1: P1-DIMMA1/P1-DIMMA2/P1-DIMMB1/P1-DIMMB2/P1-DIMMC1/P1-DIMMC2/P1-DIMMD1/P1-DIMMD2/P1-DIMME1/P1-DIMME2/P1-DIMMF1/P1-DIMMF2/P1-DIMMG1/P1-DIMMG2/P1-DIMMH1/P1-DIMMH2 CPU2: P2-DIMMA1/P2-DIMMC1/P2-DIMMD1/P2-DIMME1/P2-DIMMF1/P2-DIMMG1
2 CPUs & 24 DIMMs	CPU1: P1-DIMMA1/P1-DIMMA2/P1-DIMMB1/P1-DIMMB2/P1-DIMMC1/P1-DIMMC2/P1-DIMMD1/P1-DIMMD2/P1-DIMME1/P1-DIMME2/P1-DIMMF1/P1-DIMMF2/P1-DIMMG1/P1-DIMMG2/P1-DIMMH1/P1-DIMMH2 CPU2: P2-DIMMA1/P2-DIMMB1/P2-DIMMC1/P2-DIMMD1/P2-DIMME1/P2-DIMMF1/P2-DIMMG1/P2-DIMMH1
2 CPUs & 32 DIMMs	CPU1: P1-DIMMA1/P1-DIMMA2/P1-DIMMB1/P1-DIMMB2/P1-DIMMC1/P1-DIMMC2/P1-DIMMD1/P1-DIMMD2/P1-DIMME1/P1-DIMME2/P1-DIMMF1/P1-DIMMF2/P1-DIMMG1/P1-DIMMG2/P1-DIMMH1/P1-DIMMH2 CPU2: P2-DIMMA1/P2-DIMMA2/P2-DIMMB1/P2-DIMMB2/P2-DIMMC1/P2-DIMMC2/P2-DIMMD1/P2-DIMMD2/P2-DIMME1/P2-DIMME2/P2-DIMMF1/P2-DIMMF2/P2-DIMMG1/P2-DIMMG2/P2-DIMMH1/P2-DIMMH2

Note: This memory configuration is recommended by Supermicro for optimal memory performance. Please use this configuration to maximize your memory performance.

DIMM Installation

Note: The DDR5 DIMM module is NOT hot-swappable and be sure to disconnect power for a minimum of 20 seconds before inserting or removing it.

1. Insert the desired number of DIMMs into the memory slots based on the recommended DIMM population tables in the previous section. Locate DIMM memory slots on the motherboard as shown on the right.

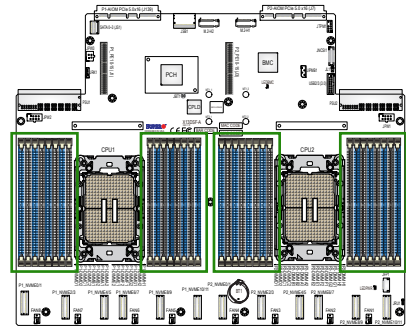

2. Push the release tabs outwards on both ends of the DIMM slot to unlock it.

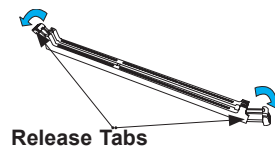

3. Align the key of the memory module with the receptive point on the memory slot.

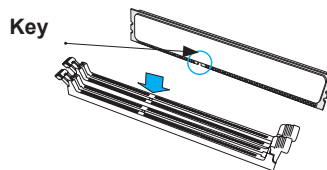

4. Align the notches on both ends of the module against the receptive points on the ends of the slot.

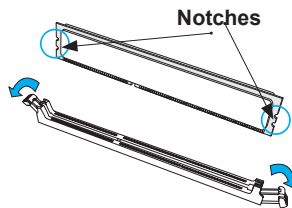

5. Push both ends of the module straight down into the slot until the module snaps into place.
6. Press the release tabs to the lock positions to secure the memory module into the slot.

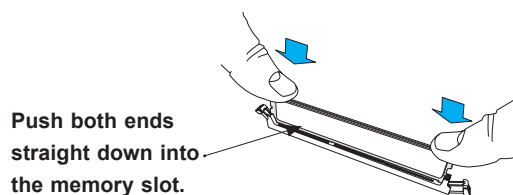

DIMM Removal

Press both release tabs on the ends of the memory module to unlock it. Once the memory module has been loosened, remove it from the memory slot.

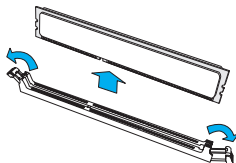

Warning! Please do not use excessive force when pressing the release tabs on the ends of the DIMM socket to avoid causing any damage to the memory module or the DIMM socket. Please handle memory modules with care. Carefully follow all the instructions given on page 1 of this chapter to avoid ESD-related damages done to your memory modules or components.

3.5 Motherboard Battery

The motherboard uses non-volatile memory to retain system information when system power is removed. This memory is powered by a lithium battery residing on the motherboard.

Replacing the Battery

Begin by [removing power](#) from the system.

1. Push aside the small clamp that covers the edge of the battery. When the battery is released, lift it out of the holder.
2. To insert a new battery, slide one edge under the lip of the holder with the positive (+) side facing up. Then push the other side down until the clamp snaps over it.

Note: Handle used batteries carefully. Do not damage the battery in any way; a damaged battery may release hazardous materials into the environment. Do not discard a used battery in the garbage or a public landfill. Please comply with the regulations set up by your local hazardous waste management agency to dispose of your used battery properly.

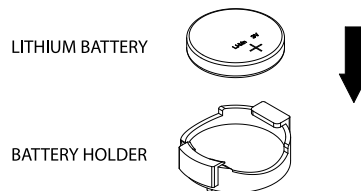

Figure 3-3. Installing the Onboard Battery

Warning: There is a danger of explosion if the onboard battery is installed upside down (which reverses its polarities). This battery must be replaced only with the same or an equivalent type recommended by the manufacturer (CR2032).

3.6 Storage Drives

The SSG-221E-NE324R supports E3.S (1T) 3.5" NVMe drives and E3.S (1T) combined with E3.S (2T) CXL 3.5" NVMe drives in front. They can be removed without powering down the system.

Note: Enterprise level storage drives are recommended for use in Supermicro chassis and servers. For information on recommended drives, visit the Supermicro website product pages at www.supermicro.com/products.

Installing Drives

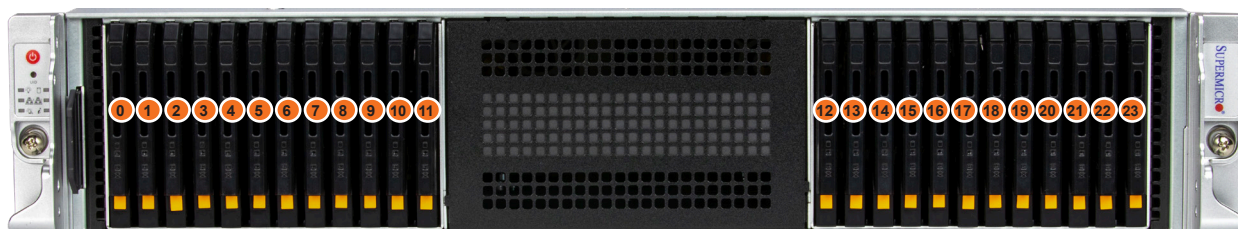

Figure 3-4. Logical Drive Numbers

Drive Carriers

The drives are mounted in drive carriers to simplify their installation and removal from the chassis. These carriers also help promote proper airflow through the drive bays. Each drive carrier has two LED indicators.

Removing Drive Carriers from the Chassis

1. The drive carriers are accessible directly from the front of the chassis.
2. To remove the carrier, use the drive carrier lever as a handle to pull the lever and slide the drive carrier out of the chassis.

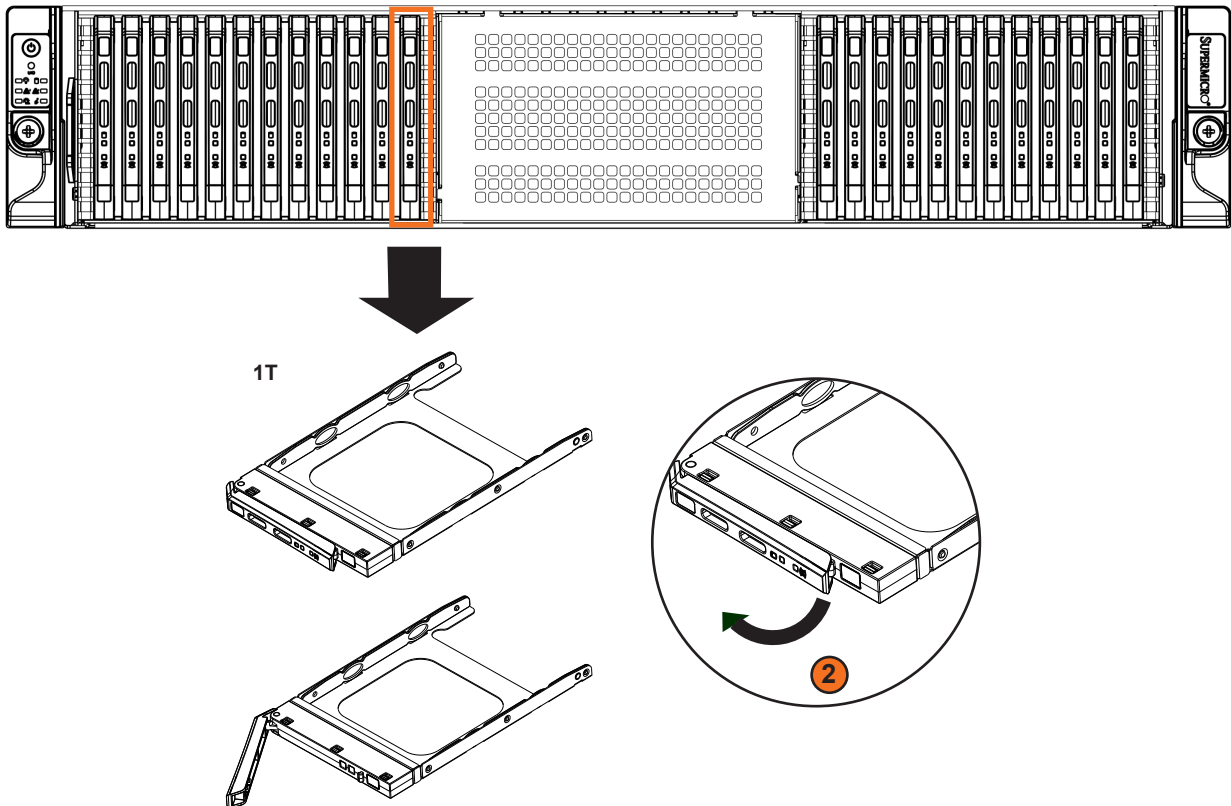
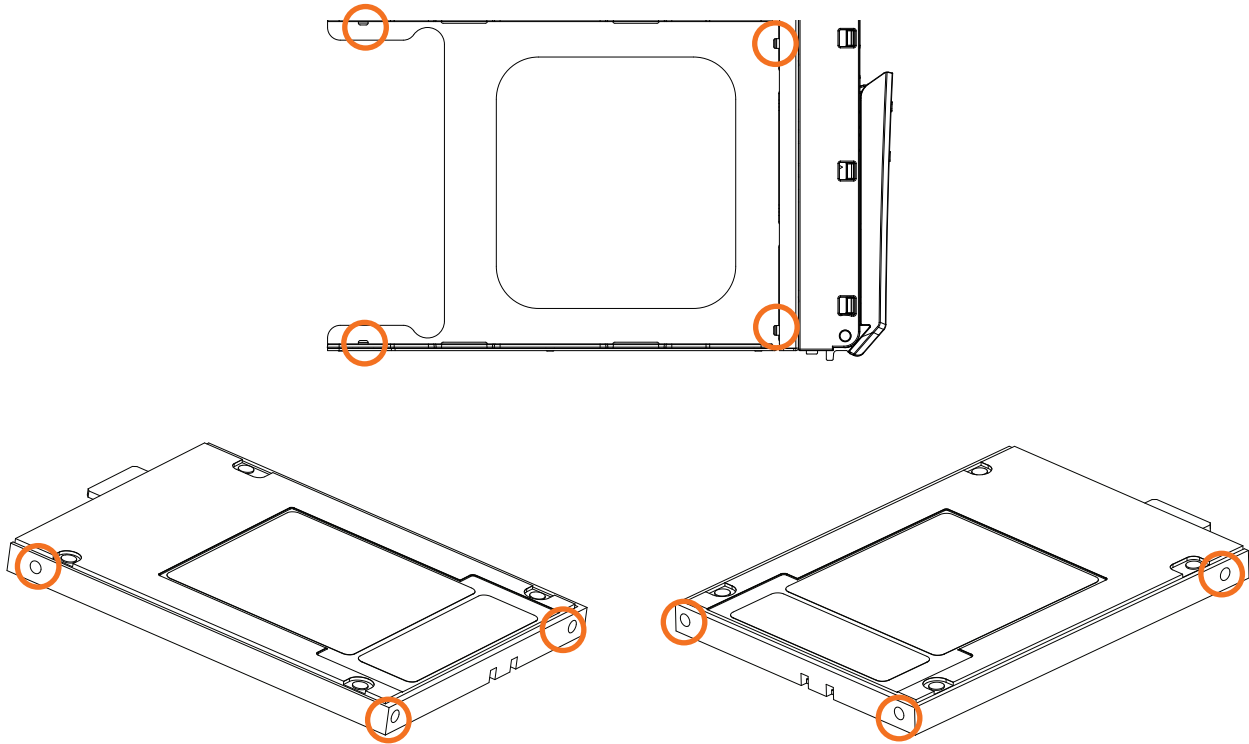

Figure 3-5. Removing a 1T Drive Carrier

Installing a Storage Drive

1. The SSG-221E-NE324R uses drive carriers to mount the storage drives.
2. These drive carriers feature four small stubs that will secure the drive. These stubs and the corresponding holes on the drives are shown below.



3. To mount a storage drive, insert the drive front in first (#1), then push the rear in (#2). The stubs will snap into place securing the drive onto the drive carrier.

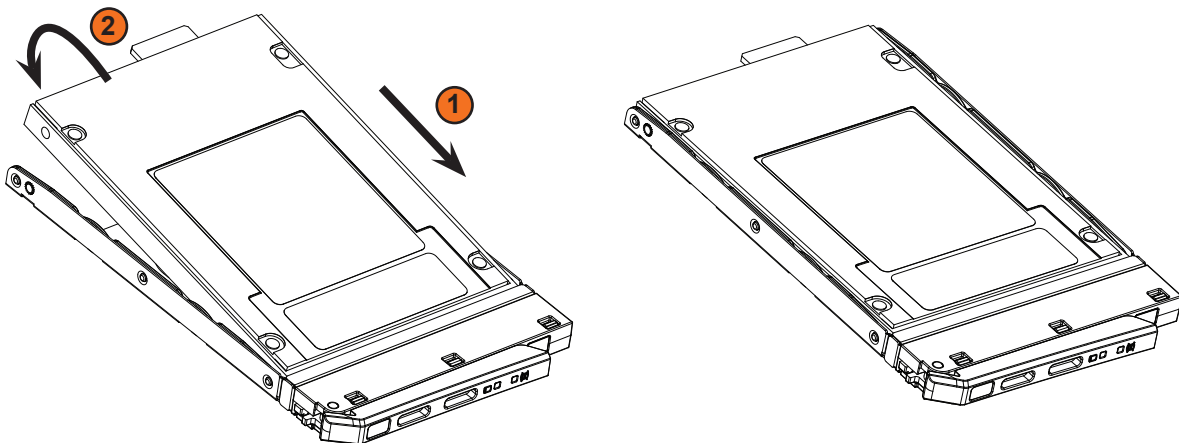
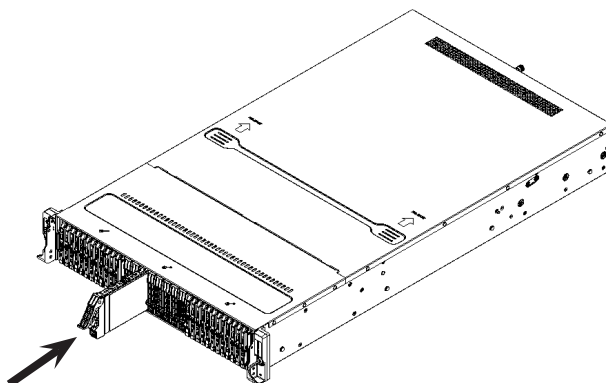

Figure 3-6. Installing a Drive into the Drive Carrier

4. Insert the drive and carrier into its bay. When the carrier reaches the rear of the bay, the release handle will retract.



5. Using the thumb, push the drive carrier handle until it clicks into the locked position.

Caution: Except for short periods of time, such as swapping drives, do not operate the server with the drive bays empty.

Note: Enterprise level storage drives are recommended for use in Supermicro chassis and servers. For information on recommended drives, visit the Supermicro website at <http://www.supermicro.com/products/nfo/files/storage/SBB-HDDCompList.pdf>.

3.7 Installing an OCP NIC Card

What is an OCP NIC card?

An OCP NIC, also known as an Open Compute Project Network Interface Card, is a type of network interface card designed according to the specifications and standards set forth by the Open Compute Project (OCP). The Open Compute Project is an initiative that aims to design and develop open hardware solutions for data centers and other computing environments.

An OCP NIC typically features a modular and open design, allowing for greater flexibility and interoperability within data center environments. These network interface cards are intended to be used in conjunction with OCP-compatible servers and networking equipment. OCP NICs are often optimized for high-performance, low-latency networking, and can support various network speeds such as 10 Gigabit Ethernet (10 GbE), 25 Gigabit Ethernet (25 GbE), 40 Gigabit Ethernet (40 GbE), or higher.

Installing an OCP Card

1. Power down the system as described earlier in this section.
2. Insert the OCP NIC card into an empty slot on the rear.
3. Tighten the small thumb screw that will secure the OCP NIC on the rear of the chassis. Do not over-tighten.

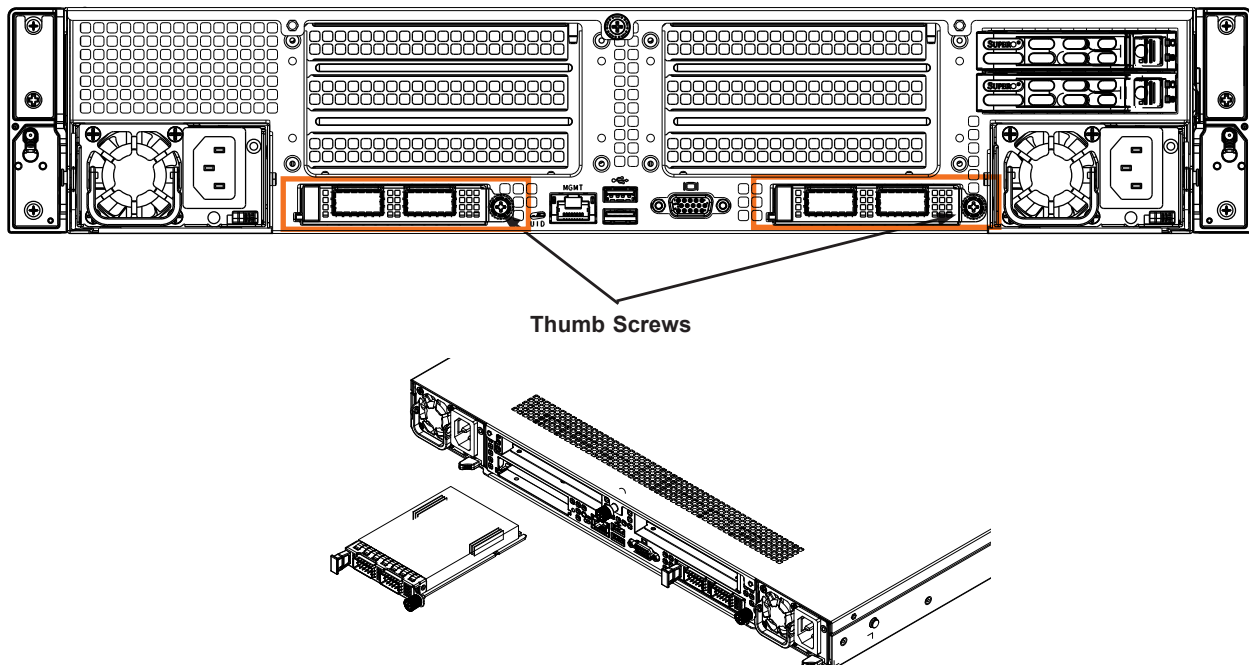

Figure 3-7. Inserting the OCP NIC

3.8 System Cooling

Eight 8-cm heavy-duty fans provide cooling for the system. They can be replaced without powering down the system.

Replacing a System Fan

1. If necessary, open the chassis while the power is running to determine which fan requires changing. (Never run the server for an extended period of time with the chassis open.)
2. Remove the chassis from the rack and seat it on a work bench (safety area). Open the mid-chassis cover as described in Section 3.2.
3. Lift fan housing that with the failed fan (or empty space, if new fan) from the chassis and pull it completely out of the chassis.
4. Place/Replace the new fan into the space in the housing while making sure the arrows on the top of the fan (indicating air direction) point in the same direction as the arrows on the other fans.
5. Replace the fan housing containing the new fan into the chassis.
6. The fan will automatically begin running at the correct speed.

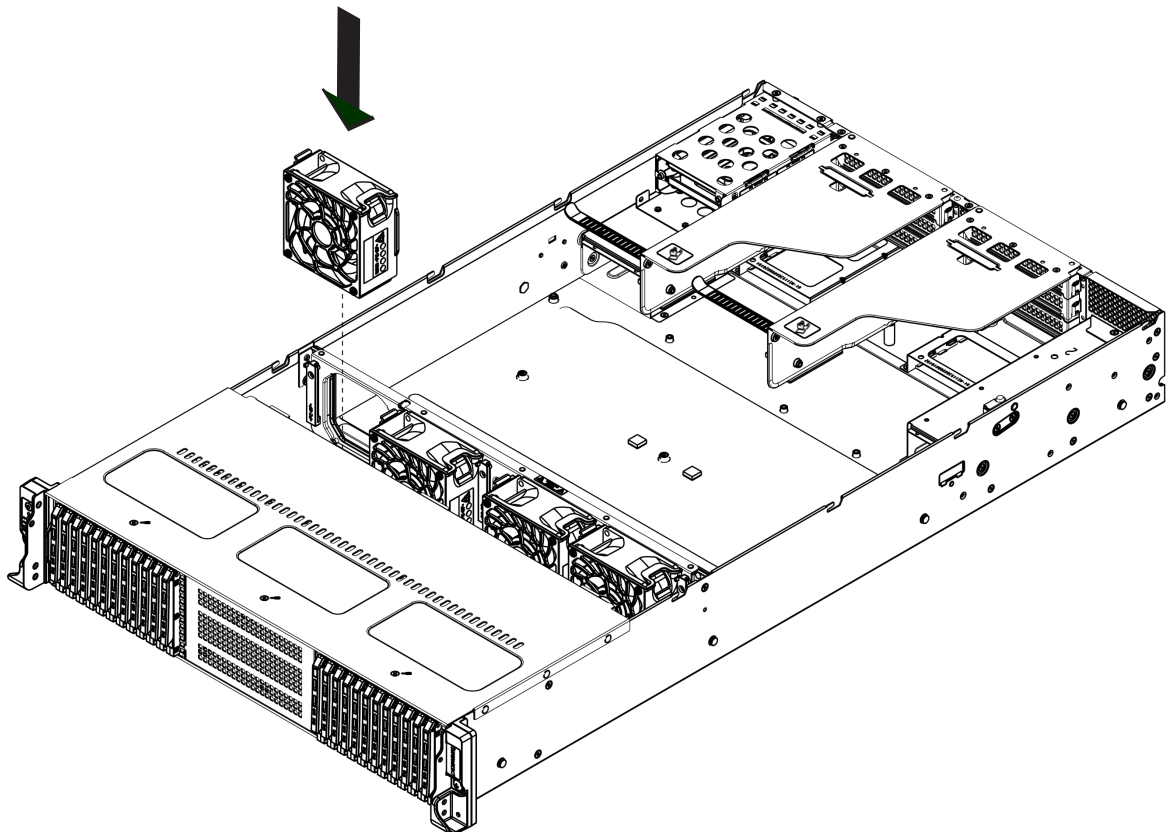

Figure 3-8. Placing a System Fan

Installing the Air Shrouds

Air shrouds concentrate airflow to maximize fan efficiency. They do not require screws to install.

Installing the Standard Air Shrouds

- Position the air shrouds as illustrated in the figure below, sliding the front over the edge of the fan tray. Align the holes in the edge of the shrouds with the hold in the fan tray.

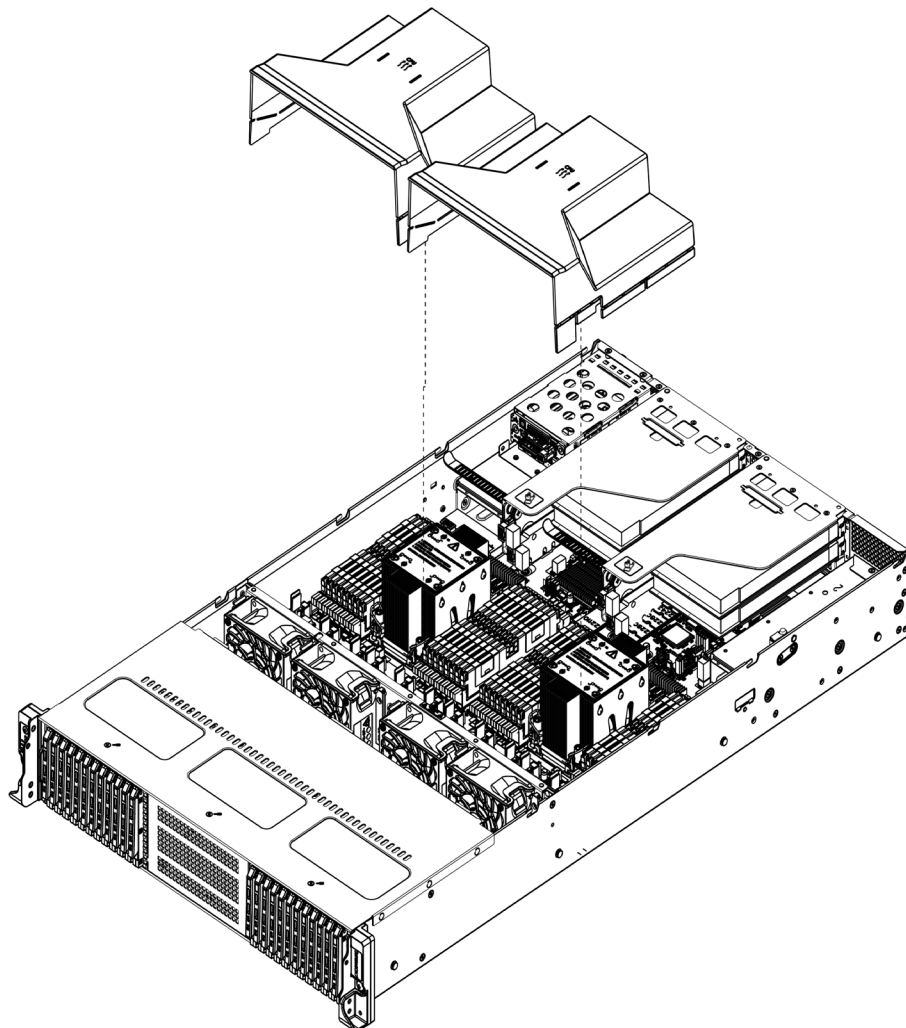

Figure 3-9. Installing the Air Shrouds

3.9 Power Supply

The chassis features redundant 2000 W power supplies. The power modules can be changed without powering down the system. New units can be ordered directly from Supermicro or authorized distributors.

These power supplies are auto-switching capable. This feature enables them to automatically sense the input voltage and operate at a 100-120 V or 180-240 V. An amber light will be illuminated on the power supply when the power is off. An illuminated green light indicates that the power supply is operating.

Changing the Power Supply

1. Unplug the AC cord from the module to be replaced.
2. Push the release tab on the back of the power supply as illustrated.
3. Pull the power supply out using the handle provided.

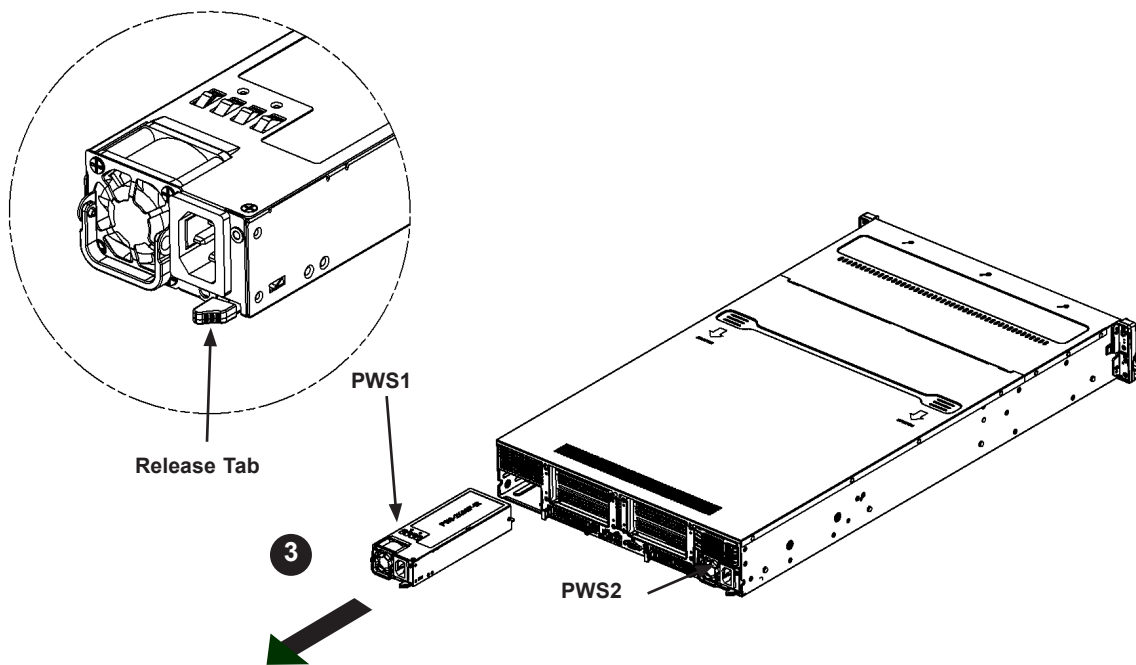

Figure 3-10. Power Supply Release Tab

4. Replace the failed power module with the same model.
5. Push the new power supply module into the power bay until it clicks.
6. Plug the AC power cord back into the module.

3.10 PCI Expansion Cards

The system accepts up to four PCIe 5.0 expansion cards and two PCIe 5.0 AIOM cards.



Figure 3-11. Expansion Slots

Expansion Slot Locations	
Slot	Description
1, 2	PCIe FHHL Gen5 x8 (slot 1) x16 (slot 2). x8 mode when slots 1 and 2 are used.
3, 4	PCIe FHHL Gen5 x8 (slot 3) x16 (slot 4). x8 mode when slots 3 and 4 are used.
A1, A2	Gen5 AIOM1, AIOM2

CPU1 ■ CPU2 ■

Installing an Expansion Cards

1. Power down the system and remove rear cover as described in [Section 3.1](#).
2. In the rear of the chassis, remove one of the two PCIe brackets from the rear of the chassis. There no screws to remove.
3. Insert the PCIe expansion card into the bracket. Secure the card into the bracket with a screw.
4. Replace the bracket with the installed expansion card into the PCIe slot.
5. Replace the top covers and power up the system.

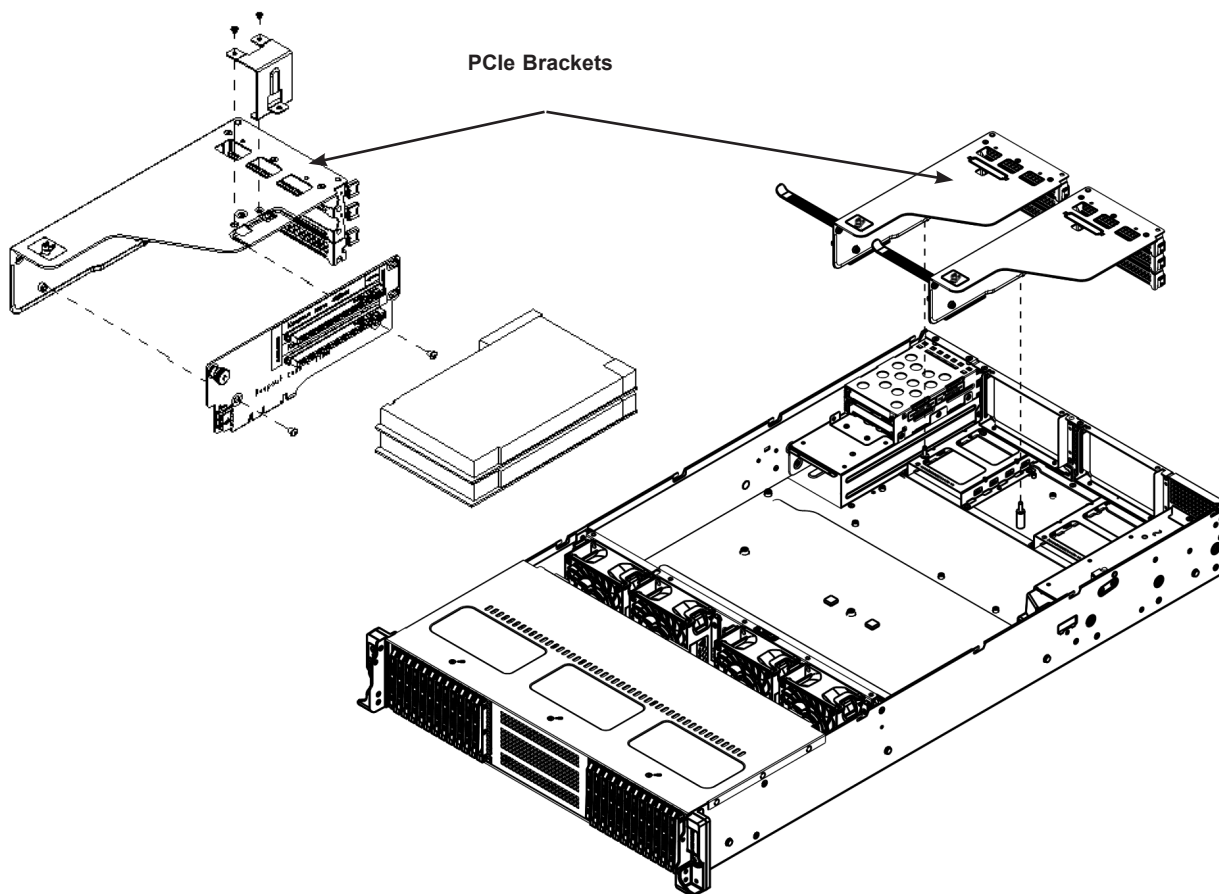

Figure 3-12. Installing PCIe Expansion Cards

3.11 Cable Routing Diagram

Use this section to route or reroute cables. Proper routing is important to maintain airflow through the system.

Cable part numbers and descriptions are available at the [Online Cable Matrix](#).

MCIO Cable

CBL-MCIO-1422LO5Y

P1_NVME0/1 to SSD 0-1
 P1_NVME2/3 to SSD 2-3
 P1_NVME4/5 to SSD 4-5
 P1_NVME6/7 to SSD 6-7
 P1_NVME8/9 to SSD 8-9
 P1_NVME10/11 to SSD 10-11

P2_NVME0/1 to SSD 12-13
 P2_NVME2/3 to SSD 14-15
 P2_NVME4/5 to SSD 16-17
 P2_NVME6/7 to SSD 18-19
 P2_NVME8/9 to SSD 20-21
 P2_NVME10/11 to SSD 22-23

Backplane Power Cables

CBL-PWEX-1142B-45

JPW1 to JPWR1
 JPW2 to JPWR2

Front Panel Cable

Ribbon cable to JFP1

USB Cable

CBL-SAST-1215X-85

JSB1 to JSB2

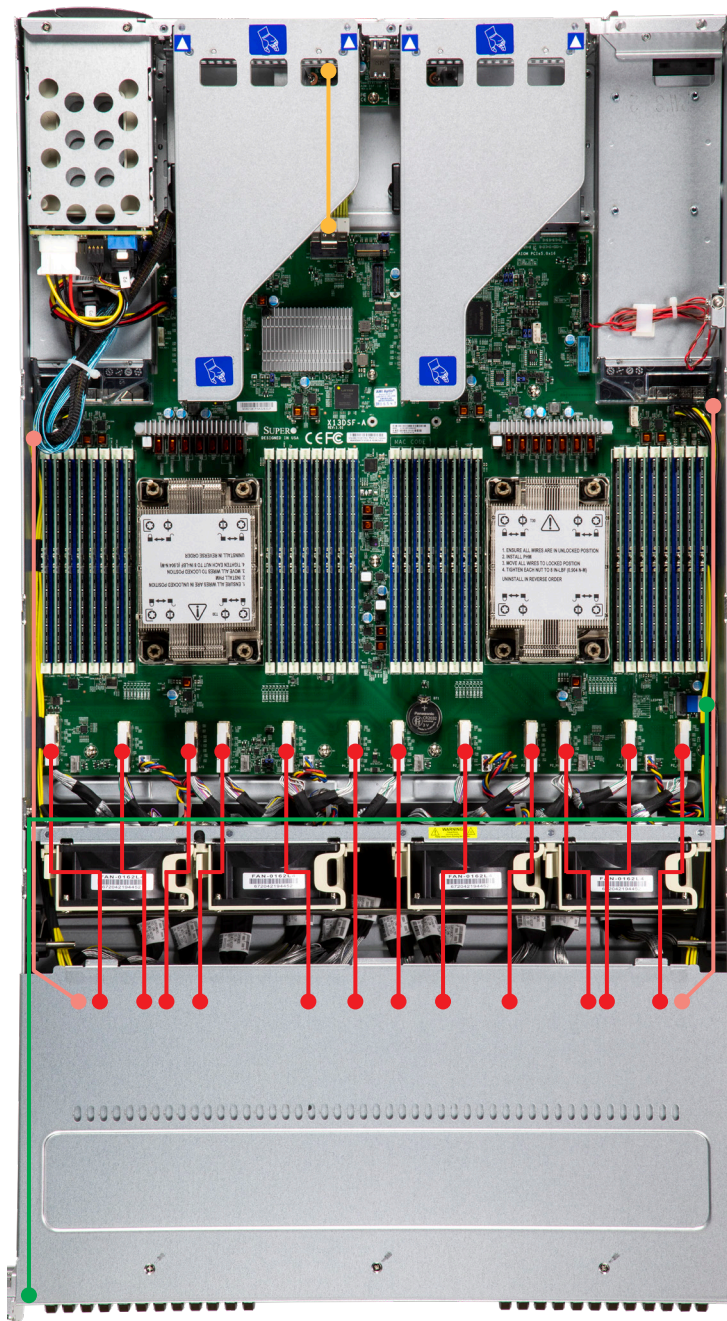

Figure 3-13. Cable Routing Diagram

Chapter 4

Motherboard Connections

This section describes the jumpers, connections and LEDs on the motherboard and provides pinout definitions. Some connections might not be used in this system. A motherboard layout indicating component locations may be found in [Chapter 1](#). More detail can be found in the [Motherboard Manual](#).

4.1 Power Connections

Two power supply connectors, located at PSU1/PSU2, provide main power to your system. The two 8-pin power connectors (JPW1, JPW2) and one 4-pin power connector (JPW3) provide additional power for system use. All these power connectors meet the ATX SSI EPS 12 V specification and must be connected to your power supply to provide adequate power to your system.

Important: To provide adequate power to your system, be sure to connect the main power connectors (PSU1, PSU2) to the power supplies. Failure to do so may void the manufacturer warranty on your power supply and motherboard.

12 V 8-pin Power Pin Definitions	
Pin#	Definition
1 - 4	Ground
5 - 8	+12 V

Required Connection

5 V/12 V 4-pin Power Pin Definitions	
Pin#	Definition
1	Ground
2	Ground
3	+12 V
4	+5 V

Required Connection

4.2 Headers and Connectors

Fan Headers

There are eight 4-pin fan headers (FAN1 - FAN8) on the motherboard. These fan headers are used for the cooling fans for your system. All these 4-pin fan headers are backwards compatible with the traditional 3-pin fans. However, fan speed control is available for 4-pin fans only by Thermal Management via the BMC 2.0 interface. Refer to the table below for pin definitions.

Fan Header Pin Definitions	
Pin#	Definition
1	Ground
2	2.5 A/+12 V
3	Tachometer
4	PWM_Control

TPM/Port 80 Header

The JTPM1 header is used to connect a Trusted Platform Module (TPM)/Port 80, which is available from Supermicro (optional). A TPM/Port 80 connector is a security device that supports encryption and authentication in drives. It allows the motherboard to deny access if the TPM, which is associated with the drive, is not installed in the system. Please go to the following link for more information on the TPM: https://www.supermicro.com/manuals/other/AOM-TPM-9670V_9670H.pdf.

Trusted Platform Module Header Pin Definitions			
Pin#	Definition	Pin#	Definition
1	+3.3 V	2	SPI_CS#
3	RESET#	4	SPI_MISO
5	SPI_CLK	6	GND
7	SPI_MOSI	8	NC
9	+3.3 V Stdby	10	SPI_IRQ#

4-pin BMC External I²C Header

A System Management Bus header for the BMC is located at JIPMB1. Connect the appropriate cable here to use the IPMB I²C connection on your system.

NC-SI Connector

The Network Controller Sideband Interface (NC-SI) connector is located at JNCSI1. This connector is used to connect a Network Interface Card (NIC) to the motherboard to allow the onboard BMC to communicate with a network.

Note: For detailed instructions on how to configure Network Interface Card (NIC) settings, please refer to the Network Interface Card Configuration User's Guide posted on the web page under the link: <http://www.supermicro.com/support/manuals/>.

Chassis Intrusion

A Chassis Intrusion header is located at JL1 on the motherboard. Attach the appropriate cable from the chassis to inform you when the chassis is opened. Refer to the table below for pin definitions.

Chassis Intrusion Pin Definitions	
Pin#	Definition
1	Intrusion Input
2	Ground

NVMe PCIe 3.0 x4 / SATA 3.0 Hybrid M.2 Slots

Two M.2 slots are located at M.2-H1 and M.2-H2 on the motherboard. The hybrid M.2 slots support NVMe PCIe 3.0 x4 and SATA 3.0 M.2 devices in the 2280 and 22110 form factors. M.2 allows for a variety of card sizes, increased functionality, and spatial efficiency.

SATA 3.0 Connector

A SATA 3.0 connector, located at JS1, supports four SATA 3.0 connections (SATA 0-3) on the motherboard. The SATA 3.0 connector is supported by the Intel C741 chipset. Connecting a proper SATA cable to JS1 to use SATA 3.0 connections.

MCIO NVMe Connectors

12 MCIO NVMe connectors, located at P1_NVME0/1 - P1_NVME10/11 (supported by CPU1) and P2_NVME0/1 - P2_NVME10/11 (supported by CPU2), provide 24 NVMe PCIe 5.0 x4 connections on the motherboard. Use these MCIO connectors to support high-speed PCIe NVMe storage devices.

Note: When installing an NVMe device on a motherboard, please be sure to connect the NVMe port (P1_NVME0/1) first for your system to work properly.

Universal Serial Bus (USB) Header

There is one USB 3.0 header, located at USB2/3, that supports two USB connections for front access. The USB header can be used for USB support via USB cables (not included).

Front Panel USB 3.0 Header Pin Definitions			
Pin#	Definition	Pin#	Definition
1	VBUS	20	Key Pin
2	Stda_SSRX-	19	Power
3	Stda_SSRX+	18	USB3_RN
4	GND	17	USB3_RP
5	Stda_SSTX-	16	GND
6	Stda_SSTX+	15	USB3_TN
7	GND	14	USB3_TP
8	D-	13	GND
9	D+	12	USB_N
10	NC	11	USB_P

VROC RAID Key Header

An Intel VROC RAID Key header is located at JRK1 on the motherboard. Install a VROC RAID Key on JRK1 for NVMe RAID support as shown in the illustration below.

Note: For detailed instructions on how to configure VROC RAID settings, please refer to the VROC RAID Configuration User's Guide posted on the web page under the link: <https://www.supermicro.com/support/manuals/>.

Intel VROC Key Pin Definitions	
Pin#	Definition
1	Ground
2	3.3 V Standby
3	Ground
4	PCH RAID Key

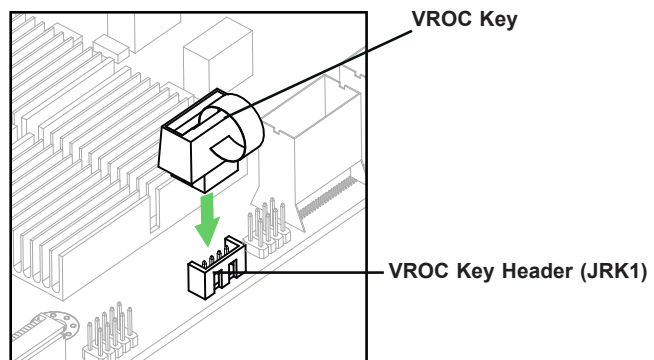

4.3 Rear I/O Connectors

Advanced I/O Module (AIOM) Connectors for Rear I/O Support

Two Supermicro proprietary Advanced I/O Module (AIOM) connectors used for PCIe 5.0 x16 add-on modules are located at P1-AIOM (J139, supported by CPU1) and P2-AIOM (J7, supported by CPU2). The two AIOM connectors provide input/output connections on the rear side of your system.

Rear I/O Module Connector

A Supermicro proprietary rear I/O module connector is located at JSB1 on the motherboard. This connector provides support for rear I/O module connection.

4.4 Connectors/Ports on the AOM-DSF-IO

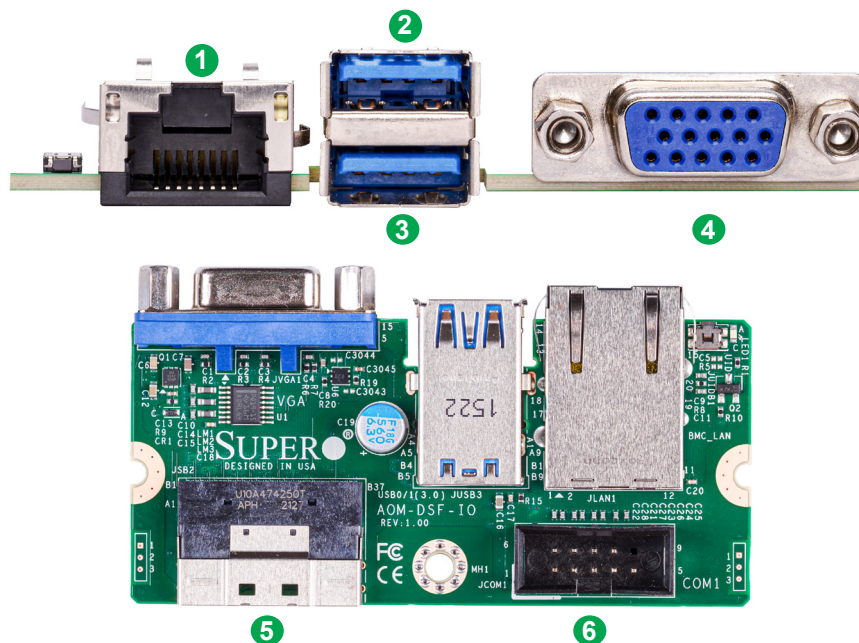

Figure 4-1. AOM-DSF-IO Ports

AOM-DSF-IO Ports	
#	Description
1	BMC_LAN Port
2	USB 0 (3.0)
3	USB 1 (3.0)
4	VGA Port
5	I/O Connector
6	COM Port Header

BMC LAN Port

A dedicated BMC LAN port (BMC_LAN) is located on the AOM-DSF-IO. The dedicated BMC LAN port provides LAN support for the Baseboard Management Controller (BMC). Connect an RJ45 cable to this LAN port for BMC LAN support.

COM Header

One COM header that supports serial link interface is on the AOM-DSF-IO. This COM header is located at COM1.

I/O Module Connector

An I/O module connector is located at JSB2 on the AOM-DSF-IO. Use JSB2 to connect the I/O module to the motherboard.

UID (Unit Identification)/BMC Reset Switch and UID/BMC Reset LED Indicators

A UID LED/BMC Reset switch (JUIDB1) is located on the AOM-DSF-IO. This switch has dual functions. It can be used to identify a system unit that is in need of service, and it can also be used to reset the BMC settings.

When functioning as a BMC reset switch, JUIDB1 will trigger a cold reboot when you press and hold the switch for six seconds. It will also restore the BMC to the manufacturer's default when you press and hold the switch for 12 seconds.

When functioning as a UID LED switch, JUIDB1 will turn both rear UID LED (LED1) on the AOM-DSF-IO and front UID LED (Pin 3/Pin 4 of JFP1) on the motherboard on and off when you press the switch on/off.

To achieve these dual purposes, the UID LED/BMC Reset switch works in conjunction with the BMC Heartbeat LED (LEDBMC) on the motherboard and front/rear UID LEDs. Please note that UID can also be triggered via BMC on the motherboard. For more details on the UID LEDs and BMC LEDs, refer to the tables below. Also, refer to the BMC User's Guide posted on our website at <https://www.supermicro.com> for more information on BMC.

UID/BMC Reset Switch (JUIDB1) Features and Settings					
When Used as a UID LED Switch			When Used as a BMC Reset Switch		
Work w/ Rear UID LED (LED1) and Front UID LED (JFP1: Pin 3 and Pin 4)			Work with BMC Heartbeat LED (LEDBMC)		
Rear UID LED	LED1	Blue: Unit identified	BMC Heartbeat LED	LEDBMC	Blinking green: BMC Normal
Front UID LED	Pin 3/Pin 4 (JFP1)	Blue: Unit identified	BMC Reset: Press and hold the switch (JUIDB1) six seconds	LEDBMC: Solid green: during reboot	Triggering a cold reboot; LED: solid green on during cold reboot
Press the switch (JUIDB1) to turn on and off both rear and front UID LED indicators;			BMC Reset: Press and hold the switch (JUIDB1) 12 seconds	LEDBMC: Solid green: during BMC reset	BMC: Reset to the manufacturer's default; LED: solid on during BMC Reset

UID/BMC Reset Switch (JUIDB1) Pin Definitions	
Pin#	Definition
1	Ground
2	Ground
3	Button In
4	Button In

Universal Serial Bus (USB) Ports

There are two USB 3.0 ports (USB0, USB1) on the AOM-DSF-IO. These USB ports can be used for USB support via USB cables (not included).

VGA Connections

There is one VGA connection in your system. The rear VGA connection is located at VGA on the AOM-DSF-IO. The VGA connection provides analog interface support between the computer and the video displays.

4.5 Front Control Panel

Front Control Panel Header with I²C

There is one front control panel headers located on this motherboard. The front control panel header, located at JFP1, contains header pins for various buttons and LED indications with I²C support for front access. This front control panel header is designed specifically for use with Supermicro chassis. Refer to the figure below for the pin-out descriptions for JFP1.

JFP1

1	○	Power Button
2	○	Reset/UID Button
3	○	UID LED_N
4	○	Fail LED_N (OH/FF/PF)
5	○	LAN-2 Activity LED
6	○	LAN-1 Activity LED (Aggregate all LAN
7	○	Drive Acitivity LED
8	○	Standby LED_N
9	○	Power/RoT LED_N
10	○	P3V3_STBY
11	○	Ground
12	○	I2C Data
13	○	I2C Clock
14	○	Ground
15	○	Power Fail LED_P
16	○	P5V
17	○	P5V
18	○	P5V
19	○	Power Fail LED_N
20	○	Ground

Figure 4-2. JFP1 Header Pins

Front Control Panel LEDs

Front Control Panel (JFP1) LED Indicators						
Event	Power	Drive	LAN	UID	Information	Power Fail
Power On	Solid On					
Drive Activity		Blinking				
NIC Activity			Blinking			
Overheat					Solid On	
Fan Fail					Blinking at 1 Hz	
Power Fail					Blinking at 1/4 Hz	Solid On
Local UID On				Solid On		
Remote UID On				Blinking at 1 Hz		
Checking	BMC/BIOS Blinking at 4Hz					
Recovering/Updating	BMC Blinking at 4Hz BMC 2 Blinks at 4 Hz, 1 Pause at 2 Hz (on-on-off-off)			BIOS/BMC Blinking at 10 Hz		
Flash Not Detected or Golden Image Check Failed	BMC/BIOS Blinking at 1 Hz					
CPLD Recovery Mode				Blinking at 10 Hz (MB UID LED)	Blinking at 10 Hz (FP Red LED)	

UID/BMC Reset Switch (JUIDB1) Features and Settings		
When Used as a UID LED Switch	When Used as a BMC Reset Switch	
Work with Rear UID LED (LED1) and Front UID LED (JFP1: Pin 3 and Pin 4)	Work with Rear UID LED (LED1) and Front UID LED (JFP1: Pin 3 and Pin 4)	
LED solid on: Unit identified; Press JUIDB1 to turn on and off both rear and front UID LED indicators	LED blinking: BMC reset	
LED blink at 1 Hz: Remote activated	BMC Reset Type 1	Triggering a (BMC) cold reboot; LED: Starts blinking at 2 Hz while pressing and holding JUIDB1 for more than six seconds; Reset duration: 250 ms
LED blink at 10 Hz: BIOS/BMC FW update	BMC Reset Type 2	Triggering a (BMC) reset to factory default configuration; LED: Starts blinking at 4 Hz while pressing and holding JUIDB1 for more than 12 seconds

Power On and BMC/BIOS Status LED Button

The Power On and BMC/BIOS Status LED button is located on Pin 1 of the front control panel header located at JFP1. Momentarily contacting Pin 1 of JFP1 will power on/off the system or display BMC/BIOS status. Refer to the table below for more information.

Power Button BMC/BIOS Status LED Indicator	
Status	Event
Green: solid on	System power on
BMC/BIOS blinking green at 4 Hz	BMC/BIOS checking
BIOS blinking green at 4 Hz	BIOS recovery/update in progress
BMC blinking red x2 (2 blinks red) at 4 Hz, 1 pause at 2 Hz (on-on-off-off)	BMC recovery/update in progress
BMC/BIOS blinking green at 1 Hz	Flash not detected or golden image checking failure

Front UID Switch/Reset Button

The Front UID switch/BMC Reset button/System Reset button connection is located on Pin 2 of JFP1, which is used in conjunction with the Reset button/UID switch select jumper located at JRU1. To configure Pin 2 of JFP1 for front UID switch and BMC reset use in a chassis that supports front UID connection, close Pin 1 and Pin 2 of JRU1. To set Pin 2 of JFP1 for system reset support, close Pin 2 and Pin 3 of JRU1.

Front UID Switch/Reset Button Select Jumper (JRU1) Jumper Settings	
State	Description
Close Pin 1 and Pin 2 of JRU1	Pin 2 of JFP1: used for front UID switch and BMC reset support (Default)
Close Pin 2 and Pin 3 of JRU1	Pin 2 of JFP1: used for system reset support

UID LED

The unit identifier LED connection is located on Pin 3 of JFP1. Refer to the figure below for more information on JFP1.

Fail LED (Information LED for OH/FF/PF)

The Fail LED (Information LED for OH/Fan Fail/PWR Fail) connection is located on Pin 4 of JFP1. The LED provides warnings of overheating, power failure, or fan failure. Refer to the table below for more information.

Fail LED (Information LED) (OH/Fan Fail/PWR Fail) LED States	
Status	Description
Solid red (on)	An overheat condition has occurred.
Blinking red (1 Hz)	Fan failure: check for an inoperative fan.
Blinking red (0.25 Hz)	Power failure: check for a non-operational power supply
Blinking red (10 Hz) (FP red LED)	CPLD recovery mode error(s)
Solid blue	UID has been activated locally. Use this function to locate a unit in a rack mount environment that might be in need of service.
Blinking blue (1 Hz)	Local UID has been activated locally on. Use this function to identify a unit that might be in need of service.
BIOS/BMC blinking blue (10 Hz)	BIOS/BMC: recovery and/or update in progress
Red Info LED blinking (10 Hz) and MB UID LED blue blinking (10 Hz)	CPLD: recovery and/or update in progress

LAN1/LAN2 (NIC1/NIC2)

The Network Interface Controller (NIC) LED connection for LAN Port 1 is located on Pin 6 of JFP1, and LAN Port 2 is on Pin 5. Refer to the table below.

LAN1/LAN2 LED LED States	
Color	State
NIC 2: Blinking green	LAN 2: Active
NIC 1: Blinking green	LAN 1: Active

Drive Activity LED

The drive activity LED connection is located on Pin 7 of JFP1. When this LED is blinking green, it indicates drive activity. Refer to the table below.

Drive Activity LED LED State	
Color	State
Blinking Green	Drive Active

Standby Power LED

The LED indicator for standby power is located on Pin 8 of JFP1. If this LED is on, standby power is on.

RoT (Root of Trust) Power LED

The Power LED for Root of Trust (RoT) connection is located on Pin 9 of JFP1. If this LED is on, power for the RoT chip is on.

Standby Power

A Standby Power (I²C) connection is located on Pin 10 - Pin 14 of JFP1 to provide power to the system when it is in standby mode. Refer to the table below for pin definitions.

3.3 V Standby PWR Pin Definitions	
Pin#	Definition
10	P3V3 Standby
11	Ground
12	I ² C Data
13	I ² C Clock
14	Ground

Power Fail LED Indicators

Power Failure LED Indicators are located on Pin 15 and Pin 19 of JFP1. Refer to the table below for pin definitions.

Power Fail LED Pin Definitions (JFP1)	
Pin#	Definition
15	PWR Failure LED-Positive
19	PWR Failure LED-Negative

FP Power

Front Panel power connections are located on Pin 16 - Pin 18 of JFP1 to provide power to your system. Refer to the table below for pin definitions.

FP PWR Pin Definitions	
Pin#	Definition
16	+5 V PWR
17	
18	

4.6 Jumpers

Explanation of Jumpers

To modify the operation of the motherboard, jumpers are used to choose between optional settings. Jumpers create shorts between two pins to change the function associated with it. Pin 1 is identified with a square solder pad on the printed circuit board.

Note: On a two-pin jumper, "Closed" means the jumper is on both pins and "Open" indicates the jumper is either on only one pin or has been completely removed.

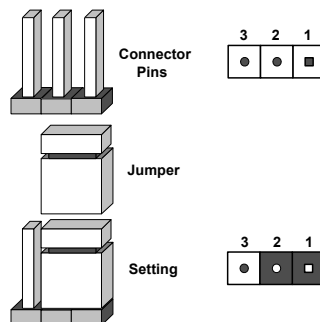

UID LED and Reset Button Select

JRU1 is used in conjunction with Pin 2 of Front Control Panel (JFP1) to function as a system reset button or a UID LED/BMC reset button. To configure Pin 2 of JFP1 for front UID switch and BMC reset use in a chassis that supports front UID connection, close Pins 1 and 2 of JRU1. To set Pin 2 of JFP1 for system reset support, close Pins 2 and 3 of JRU1. Please refer to the table below for more information on JRU1.

Front UID Switch/Reset Button Select Jumper (JRU1) Jumper Settings	
State	Description
Close Pin 1 and Pin 2 of JRU1	Pin 2 of JFP1: used for front UID switch and BMC reset support (Default)
Close Pin 2 and Pin 3 of JRU1	Pin 2 of JFP1: used for system reset support

4.7 LED Indicators

BMC Heartbeat LED

A BMC Heartbeat LED is located at LEDBMC on the motherboard. When LEDBMC is blinking green, the BMC is functioning normally.

BMC Heartbeat LED Indicator	
LED Color	Definition
Green: Blinking	BMC Normal

Onboard Power LED

The Onboard Power LED is located at LEDPWR on the motherboard. When this LED is on, the system power is on. Be sure to turn off the system power and unplug the power cords before removing or installing components. Refer to the table below for more information.

Onboard Power LED Indicator	
LED Color	Definition
Off	System Power Off (power cable not connected)
Green	System Power On

BMC LAN LEDs

The AOM-DSF-IO provides a dedicated BMC LAN connection. The LED on the right side of the BMC LAN port indicates activity, and the LED on the left indicates the speed of the connection. Refer to the table below for more information.

BMC LAN LEDs		
	Color/State	Definition
Link (left)	Green: Solid	100 Mbps
	Amber: Solid	1 Gbps
Activity (Right)	Amber: Blinking	Active

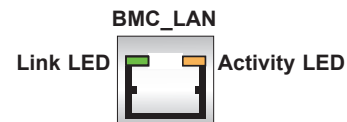

Unit ID LED

The rear UID LED indicator is located at LED1 on the AOM-DSF-IO. This UID indicator provides easy identification of a system that may need service.

UID LED LED Indicator	
LED Color	Definition
Blue: On	System Identified

Chapter 5

Software

After the hardware has been installed, you can install the Operating System (OS), configure RAID settings and install the drivers.

5.1 Microsoft Windows OS Installation

If you will be using RAID, you must configure RAID settings before installing the Windows OS and the RAID driver. Refer to the RAID Configuration User Guides posted on our website at www.supernmicro.com/support/manuals.

Installing the OS

1. Create a method to access the MS Windows installation ISO file. That might be a USB flash or media drive, perhaps using an external USB/SATA flash or media drive, or the BMC KVM console.
2. Boot from a bootable device with Windows OS installation. You can see a bootable device list by pressing **F11** during the system startup.

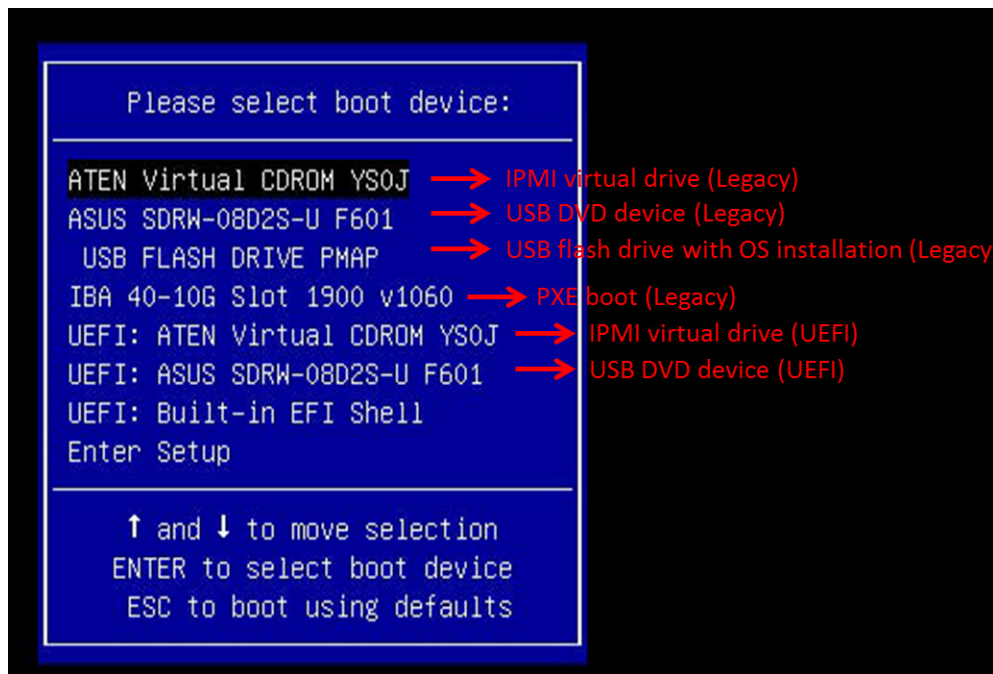

Figure 5-1. Select Boot Device

3. During Windows Setup, continue to the dialog where you select the drives on which to install Windows. If the disk you want to use is not listed, click on “Load driver” link at the bottom left corner.

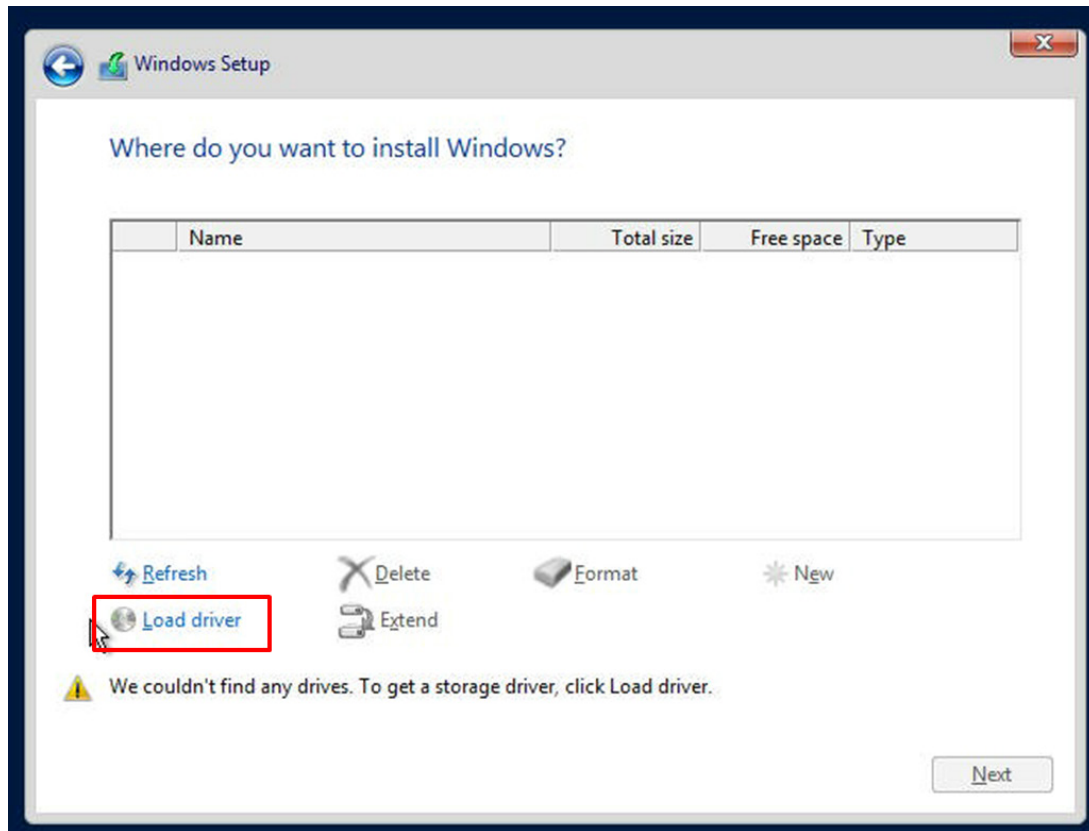

Figure 5-2. Load Driver Link

To load the driver, browse the USB flash drive for the proper driver files.

- For RAID, choose the SATA/sSATA RAID driver indicated then choose the storage drive on which you want to install it.
 - For non-RAID, choose the SATA/sSATA AHCI driver indicated then choose the storage drive on which you want to install it.
4. Once all devices are specified, continue with the installation.
 5. After the Windows OS installation has completed, the system will automatically reboot multiple times.

5.2 Driver Installation

The Supermicro website contains drivers and utilities for your system at <https://www.supermicro.com/wdl/driver>. Some of these must be installed, such as the chipset driver.

After accessing the website, go into the CDR_Images (in the parent directory of the above link) and locate the ISO file for your motherboard. Download this file to a USB flash or media drive. (You may also use a utility to extract the ISO file if preferred.)

Another option is to go to the Supermicro website at www.supermicro.com > Products. Find the product page for your motherboard, and "Download the Latest Drivers and Utilities."

Insert the flash drive or disk and the screenshot shown below should appear.

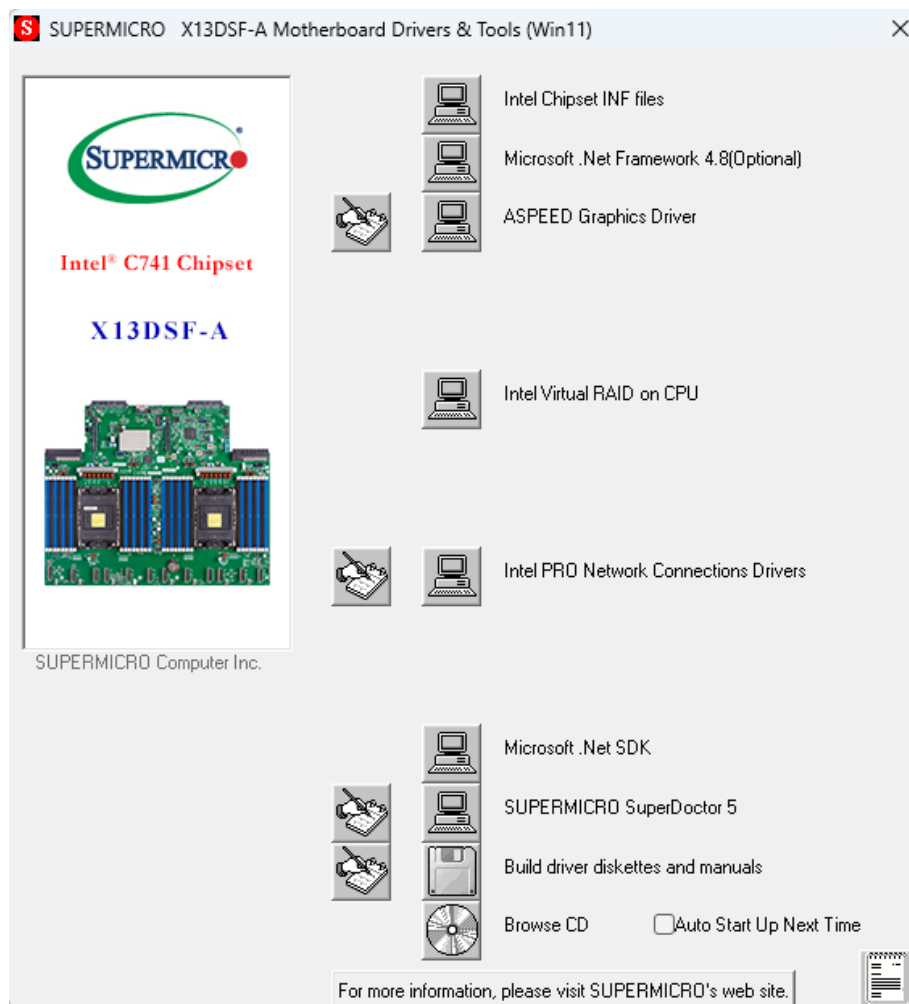

Figure 5-3. Driver and Tool Installation Screen

Note: Click the icons showing a hand writing on paper to view the readme files for each item. Click the computer icons to the right of these items to install each item (from top to bottom) one at a time. **After installing each item, you must reboot the system before moving on to the next item on the list.** The bottom icon with a CD on it allows you to view the entire contents.

5.3 BMC

The motherboard provides remote access, monitoring and management through the baseboard management controller (BMC) and other management controllers distributed among different system modules. There are several BIOS settings that are related to BMC. For general documentation and information on BMC, visit our website at:

www.supermicro.com/en/solutions/management-software/bmc-resources

BMC ADMIN User Password

For security, each system is assigned a unique default BMC password for the ADMIN user. This can be found on a sticker on the chassis and a sticker on the motherboard. The sticker also displays the BMC MAC address.

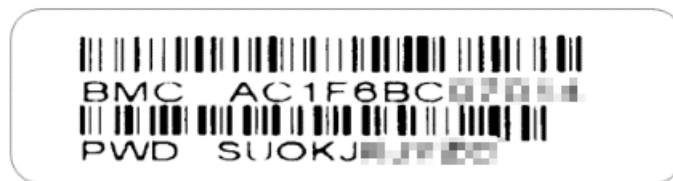

Figure 5-4. BMC Password Label

Chapter 6

Optional Components

This chapter describes optional system components and installation procedures.

Optional Parts	
Description	Part Number
Network cards	AOC-S25G-M2S
	AOC-SGP-I2
	AOC-S40G-I2Q
Power cords	CBL-PWCD-0579-1
	CBL-PWCD-0300-IS
	CBL-PWCD-0579
TPM security modules	AOM-TPM-9671V-S-O
	AOM-TPM-9670V-S-O

6.1 Storage Control Card and Cable(s)

Supernano offers storage controller cards for various data protection and drive RAID levels. Please refer to the product page for the latest cards and add-on options.

6.2 TPM Security Module

SPI capable TPM 2.0 (or 1.2) with Infineon 9670 controller, horizontal form factor

The JTPM1 header is used to connect a Trusted Platform Module (TPM). A TPM is a security device that supports encryption and authentication in drives. It enables the motherboard to deny access if the TPM associated with the drive is not installed in the system.

Details and installation procedures are at:

<http://www.supermicro.com/manuals/other/TPM.pdf>.

- AOM-TPM-9671V-S-O
- AOM-TPM-9670V-S-O

6.3 Intel Virtual RAID on CPU (VROC)

Intel® Virtual RAID on CPU (Intel VROC) is an enterprise RAID solution for NVMe SSDs directly attached to Intel Xeon Scalable processors. Intel Volume Management Device (VMD) is an integrated controller inside the CPU PCIe root complex.

- A single processor supports up to 12 NVMe SSDs and up to 6 RAID arrays.
- A dual processor system supports up to 24 NVMe SSDs and 12 RAID arrays.

Stripe sizes are 4K, 8K, 16K, 32K, 64K, 128K.

Requirements and Restrictions

- **Intel VROC is only available when the system is configured for UEFI boot mode.**
- To enable the **mdadm** command and support for RSTe, install the patch from
 - Linux: <https://downloadcenter.intel.com/download/28158/Intel-Virtual-RAID-on-CPU-Intel-VROC-and-Intel-Rapid-Storage-Technology-enterprise-Intel-RSTe-Driver-for-Linux->
 - Windows: <https://downloadcenter.intel.com/download/28108/Intel-Virtual-RAID-on-CPU-Intel-VROC-and-Intel-Rapid-Storage-Technology-enterprise-Intel-RSTe-Driver-for-Windows->
- To enable Intel VROC, a hardware key must be inserted on the motherboard, and the appropriate processor's Virtual Management Devices must be enabled in the BIOS setup.
- It is possible to enable Intel VROC without a hardware key installed, but only RAID0 will be enabled.
- Intel VROC is not compatible with secure boot. This feature must be disabled.
- When creating bootable OS RAID1 devices, you must have both devices on the same CPU, and a VMD on that CPU.
- Spanning drives when creating RAID devices is not recommended due to performance issues, even though it is supported.

Supported SSDs and Operating Systems

To see the latest support information: <https://www.intel.com/content/www/us/en/support/articles/000030310/memory-and-storage/ssd-software.html>

Additional Information

Additional information is available on the product page for the Supermicro add-on card and the linked manuals.

www.supermicro.com/products/accessories/addon/AOC-VROCxxxMOD.cfm

Hardware Key

The Intel VROC hardware key is a license key that detects the Intel VROC SKU and activates the function accordingly. The key must be plugged into the Supermicro motherboard (connector JRK1). The key options are:

Intel® VROC Keys			
VROC Package	Description	Part Number	Intel MM Number
Standard	RAID 0, 1, 10 Supports 3rd party SSDs	AOC-VROCSTNMOD	951605
Premium	RAID 0, 1, 5, 10 Supports 3rd party SSDs	AOC-VROCPREMOD	951606
Intel SSD only	RAID 0, 1, 5, 10 Supports Intel SSDs only	AOC-VROCINTMOD	956822



Figure 6-1. Intel VROC RAID Key and Motherboard Connector JRK1

Configuring NVMe RAID Manually

RAID for NVMe SSDs is enabled by default when Intel VROC Raid Key is populated. It may be managed manually through the UEFI BIOS.

1. Reboot the server and press [DEL] key to access the BIOS options.
2. Switch to **Advanced > Chipset Configuration > North Bridge > IIO Configuration > Intel® VMD Technology**.

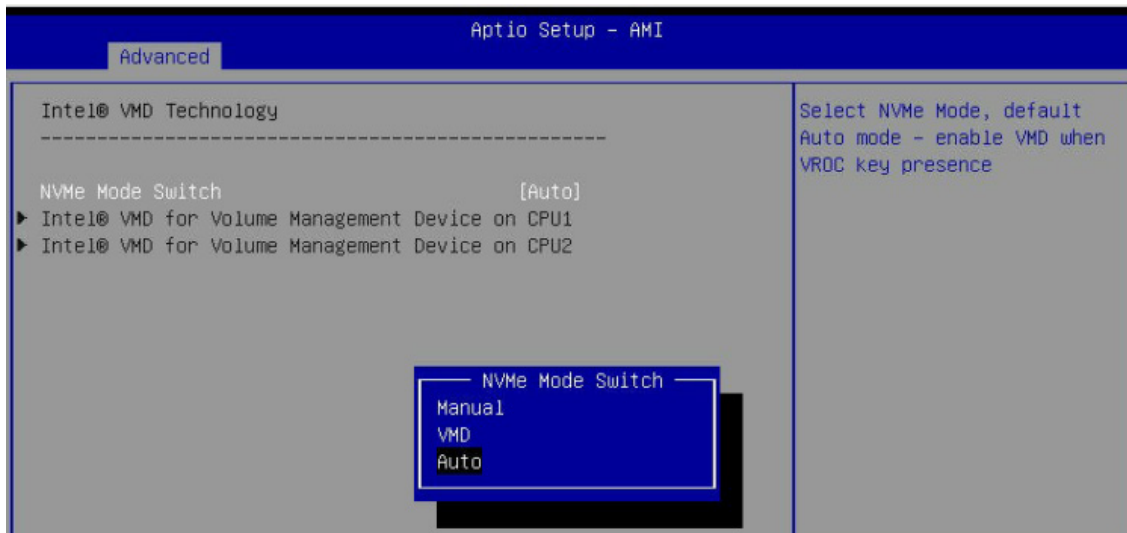

Figure 6-2. BIOS, Selecting VMD Mode

You can select a mode. The default is **Auto**. The **VMD** switch enables VMD mode for all NVMe ports despite the presence of the VROC key. The **Manual** switch allows the user to choose devices on which to enable VMD.

The onboard M.2 NVMe from PCH is located in the CPU1 section.

The screenshot on the next page shows example choices in Manual mode.

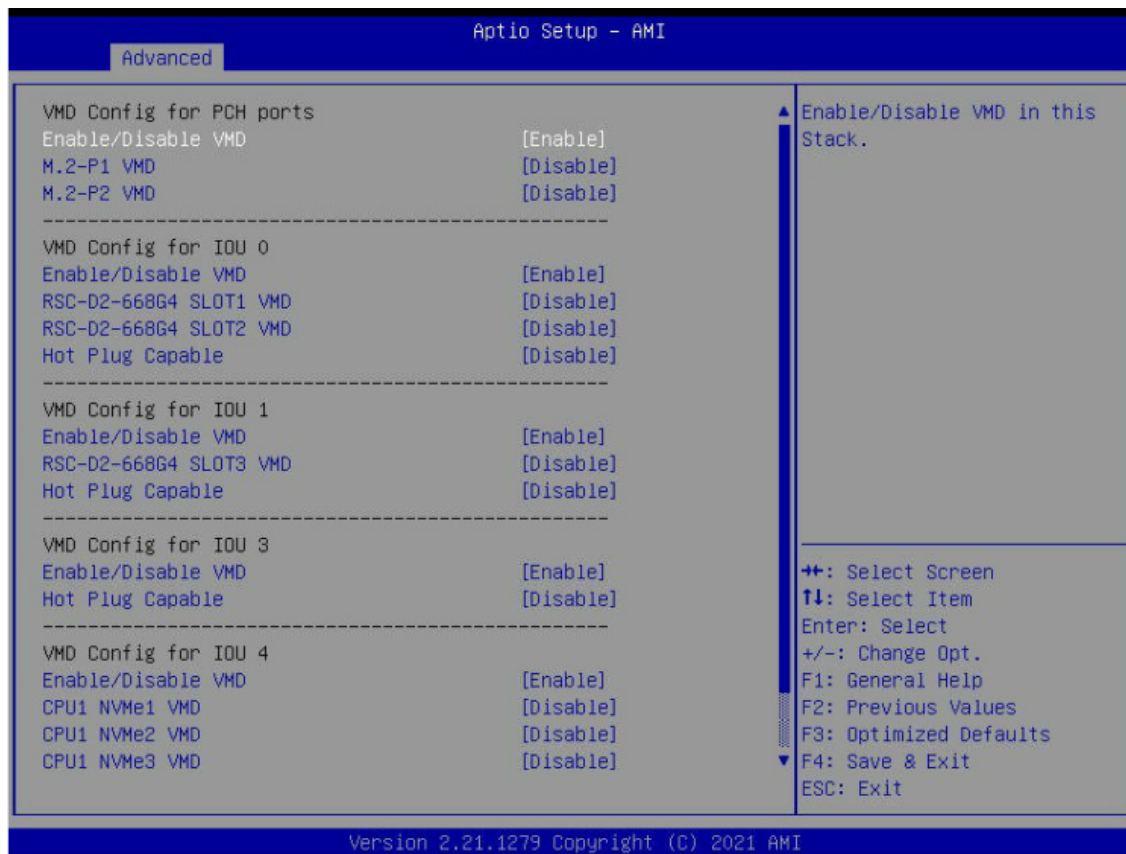

Figure 6-3. BIOS, Manual Mode (Example—your server may look different.)

3. Select the desired PStack# to Enable or Disable the corresponding Intel VMD controller

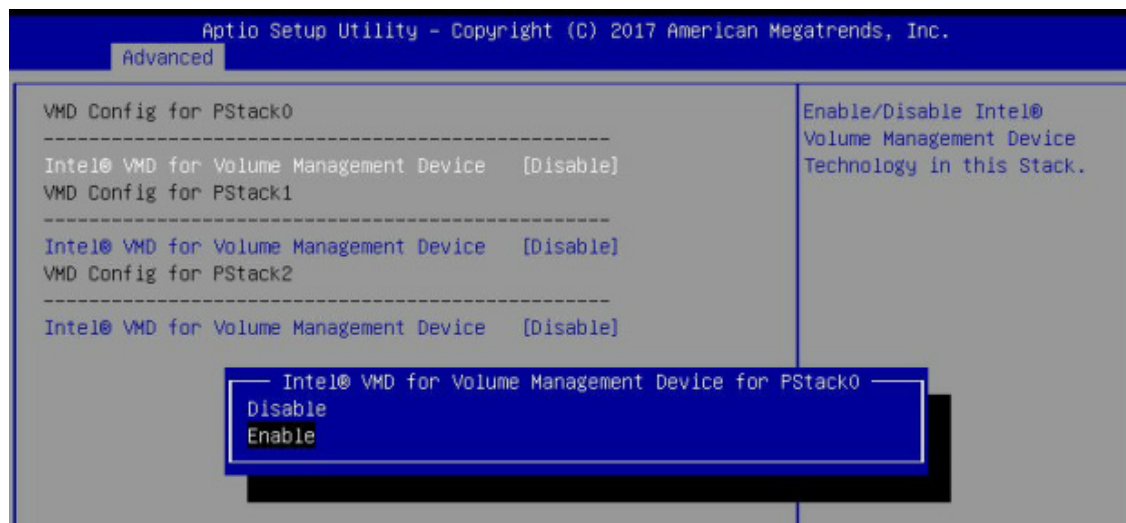

Figure 6-4. BIOS, Enabling VMD for Pstack0

- 4. Select the desired PCIe slot to Enable or Disable Intel VMD functionality according to the current hardware configuration being used. Hot Plug Capability can also be Enabled or Disabled.

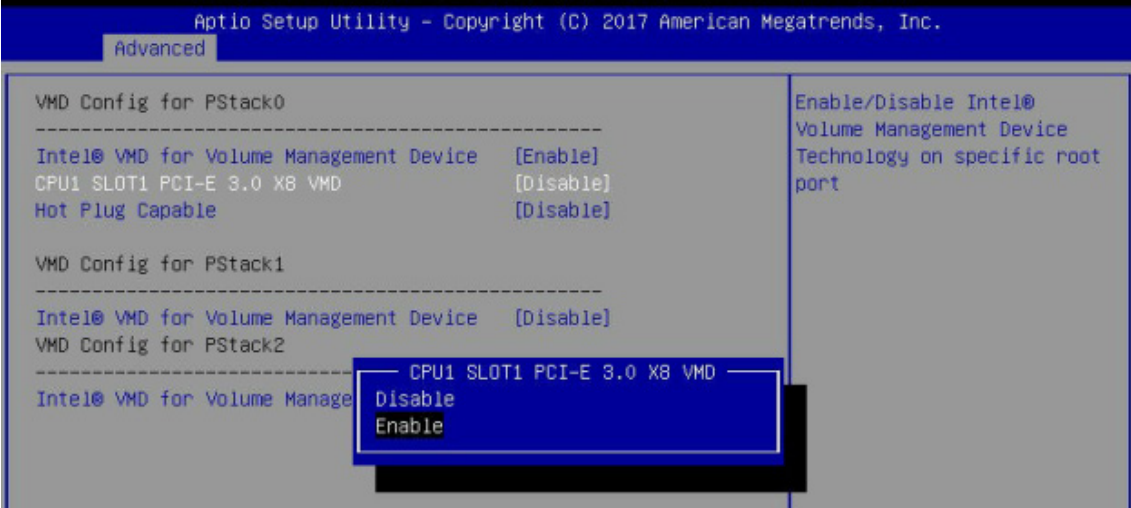

Figure 6-5. BIOS, Enabling VMD Functionality per Slot

- 5. Repeat steps 3 and 4 for each PStack# on each CPU to be enabled or disabled. In this example, we enabled CPU1 Slot1 (Figure 6-11) and CPU2 Slot5 (Figure 6-12) (four U.2 form factor SSDs), as well as CPU1 M.2 C-1 and CPU1 M2. C-2 (two M.2 form factor SSDs)

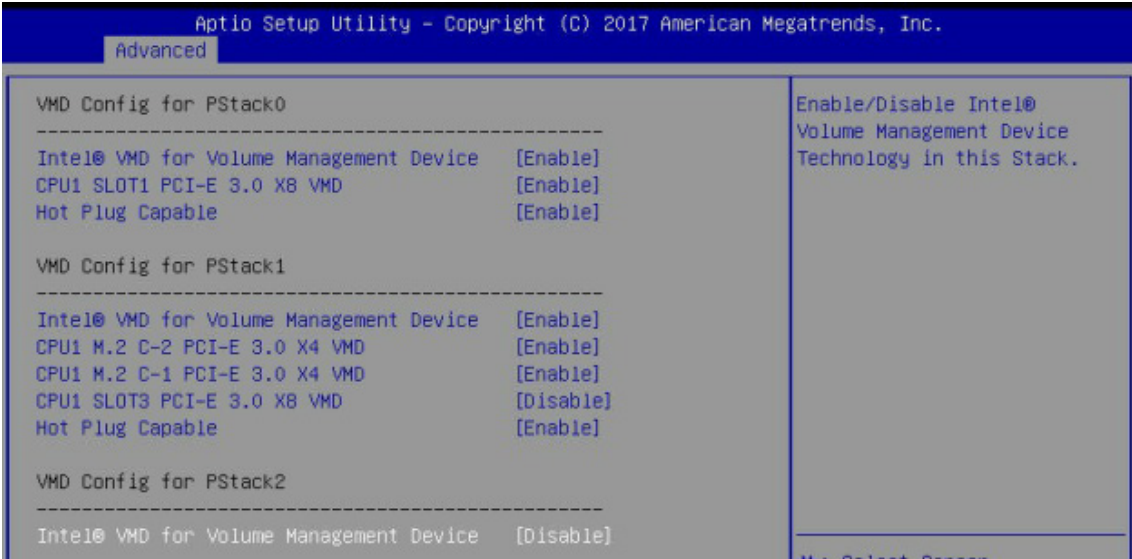

Figure 6-6. BIOS, Enabling CPU1 Example

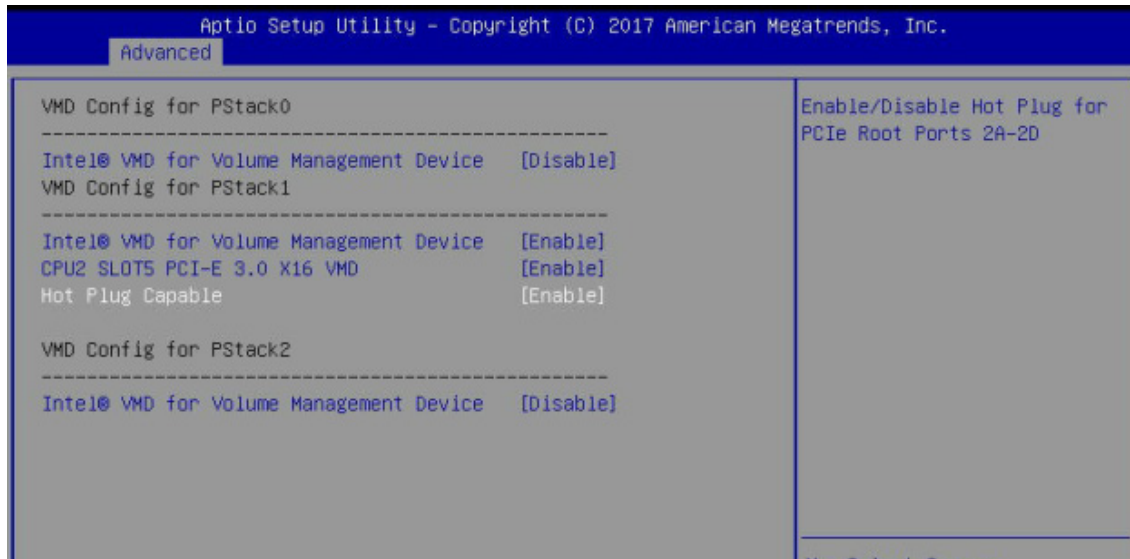

Figure 6-7. BIOS, Enabling CPU2 Example

6. Press [F4] to save the configuration and reboot the system and press [DEL] to enter BIOS.

Note: Disabling the VMD controller without first deleting the associated existing RAID volume can lead to unexpected behavior. This action is strongly not recommended.

Note: The effects of physically changing or swapping a CPU on the VMD controller enablement has not yet been thoroughly tested or documented.

7. Switch to **Advanced > Intel(R) Virtual RAID on CPU > All Intel VMD Controllers > Create RAID Volume**.
8. Set **Name**.
9. Set **RAID Level**.

10. If cross-controller RAID is required, select **Enable RAID spanned over VMD Controller**.

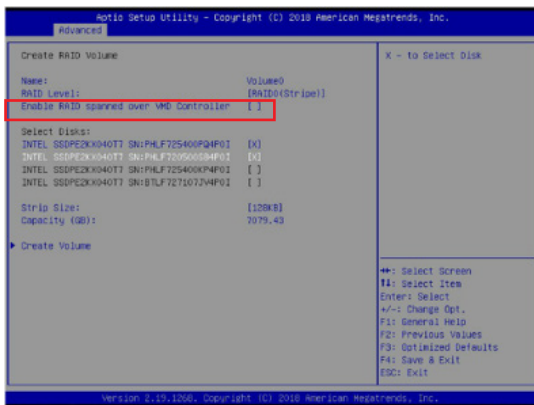

Figure 6-8. Created Volume *without* enabling RAID spanned over VMD controller

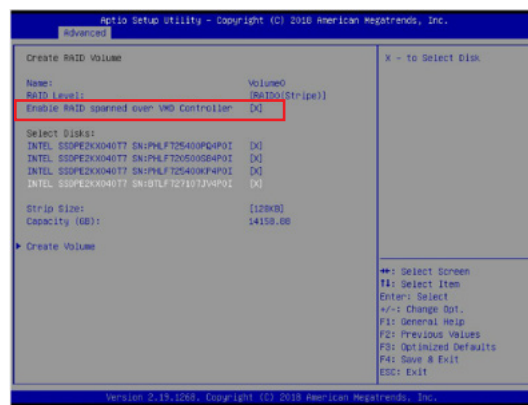

Figure 6-9. Created Volume *with* enabling RAID spanned over VMD controller

11. Select specific disks for RAID with an [X].
- RAID0: Select at least two [2 - 24] disks
 - RAID1: Select only two disks
 - RAID5: Select at least three [3 - 24] disks
 - RAID10: Select only four disks
12. Select **Strip Size** (Default 64KB).
13. Select **Create Volume**.
14. If another RAID is needed, start again at step 9.
15. Press [F4] to save and reboot.

Status Indications

An LED indicator on the drive carrier shows the RAID status of the drive.

Drive Carrier Status LED Indicator	
Status	State (red)
Normal function	Off
Locating	4 Hz blinking
Fault	Solid on
Rebuilding	1 Hz blinking

IBPI SFF 8489 Defined Status LED States

Hot Swap Drives

Intel VMD enables hot-plug and hot-unplug for NVMe SSDs, whether from Intel or other manufacturers. Under vSphere ESXi, several steps are necessary to avoid potential stability issues. See the information at link [1] below.

Hot-unplug

1. Prevent devices from being re-detected during rescan:

```
esxcli storage core claiming autoclaim --enabled=false
```

2. Unmount the VMFS volumes on the device. Check [2] for details.
3. Detach the device. Check [3] for details.
4. Physically remove the device.

Hot-plug

- Physically install the device.

ESXi will automatically discover NVMe SSDs, but a manual scan may be required in some cases.

Related Information Links

[1] <https://kb.vmware.com/s/article/2151404>

[2] <https://docs.vmware.com/en/VMware-vSphere/6.5/com.vmware.vsphere.storage.doc/GUID-1B56EF97-F60E-4F21-82A7-8F2A7294604D.html>

[3] <https://docs.vmware.com/en/VMware-vSphere/6.5/com.vmware.vsphere.storage.doc/GUID-F2E75F67-740B-4406-9F0C-A2D99A698F2A.html>

Chapter 7

Troubleshooting and Support

7.1 Information Resources

Website

A great deal of information is available on the Supermicro website; www.supermicro.com.

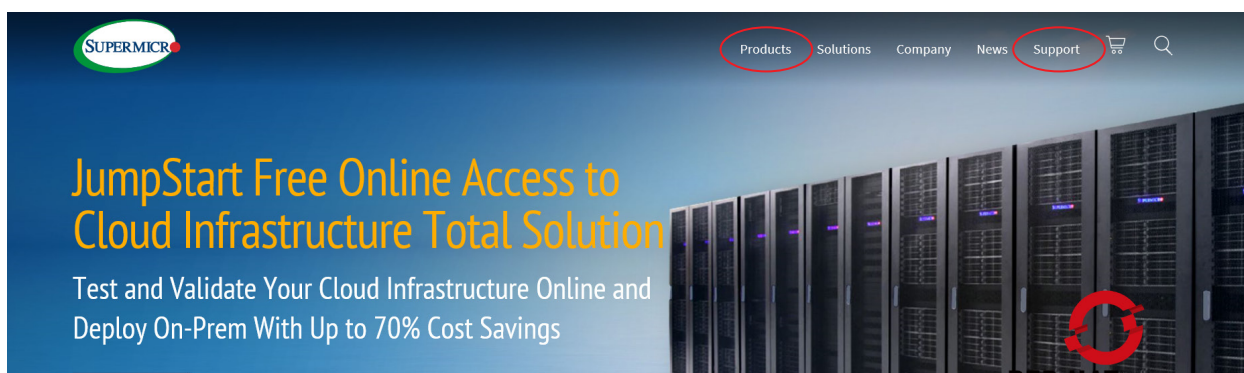

Figure 7-1. Supermicro Website

- Specifications for servers and other hardware are available by clicking the **Products** option.
- The **Support** option offers downloads (manuals, BIOS/BMC, drivers, etc.), FAQs, RMA, warranty, and other service extensions.

Direct Links for the SSG-221E-NE324R System

Web [SSG-221E-NE324R](#) specifications page

X13DSF-A [motherboard page](#) for links to the Quick Reference Guide, User Manual, validated storage drives, etc.

Direct Links for General Support and Information

[Frequently Asked Questions](#)

[TPM User Guide](#)

[SuperDoctor5 Large Deployment Guide](#)

For validated memory, use our [Product Resources page](#)

Direct Links (continued)

[Product Matrices](#) page for links to tables summarizing specs for systems, motherboards, power supplies, riser cards, add-on cards, etc.

[Security Center](#) for recent security notices

[Supermicro Phone and Addresses](#)

7.2 Baseboard Management Controller (BMC)

The system supports the Baseboard Management Controller (BMC). BMC is used to provide remote access, monitoring and management. There are several BIOS settings that are related to BMC.

For general documentation and information on BMC, please visit our website at: <https://www.supermicro.com/en/solutions/management-software/bmc-resources>.

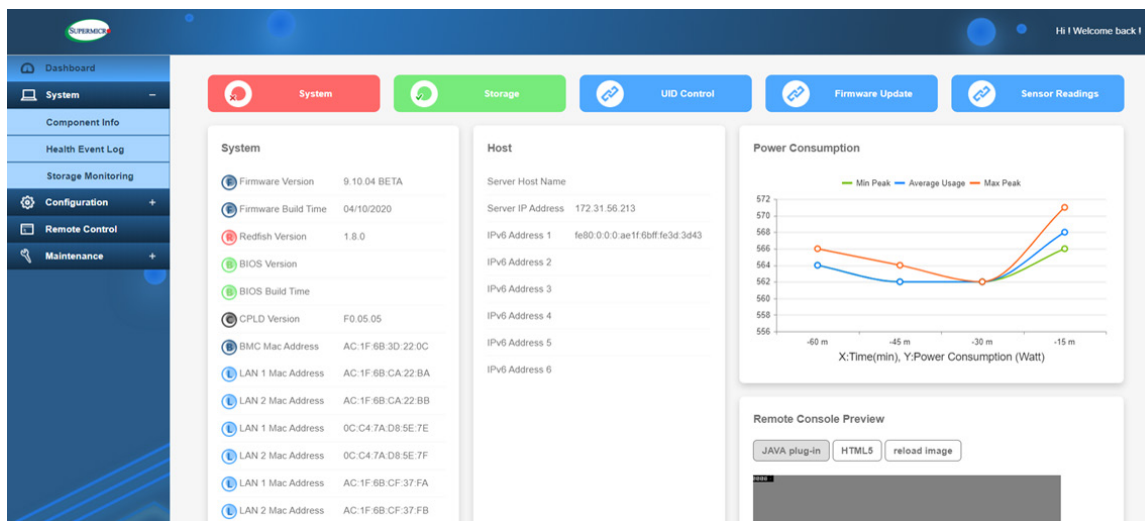

Figure 7-2. BMC Sample

7.3 Troubleshooting Procedures

Use the following procedures to troubleshoot your system. If you have followed all of the procedures below and still need assistance, refer to the [Technical Support Procedures](#) or [Returning Merchandise for Service](#) sections in this chapter. [Power down](#) the system before changing any non hot-swap hardware components.

No Power

1. As you try to power up the system, note any beep codes.
2. Check that the power LED on the motherboard is on.

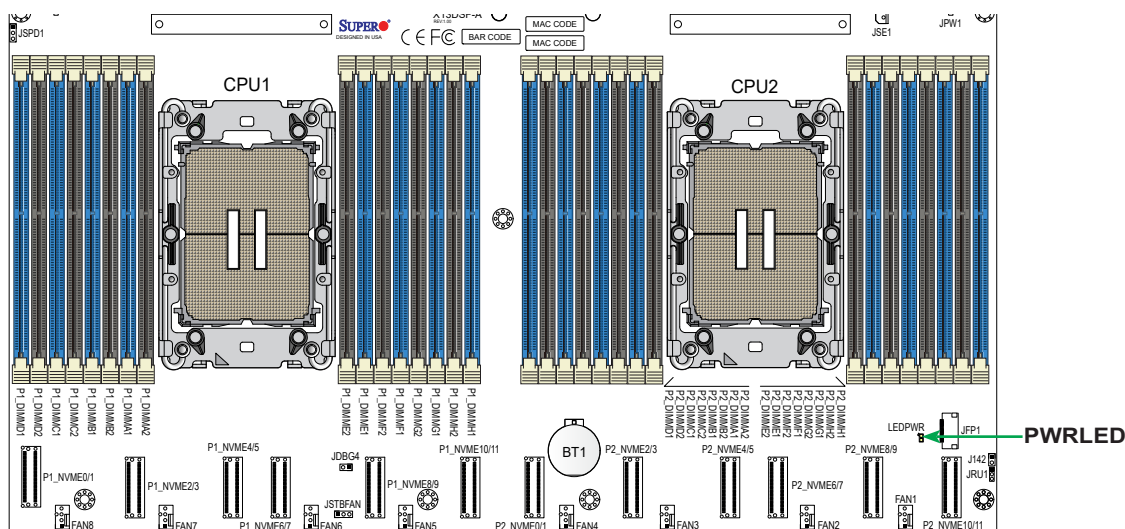

Figure 7-3. Location of the MB Power LED

3. Make sure that no short circuits exist between the motherboard and chassis.
4. Disconnect all cables from the motherboard, including those for the keyboard and mouse.
5. Remove all add-on cards.
6. Install a CPU, a heatsink, connect the internal speaker (if applicable), and the power LED to the motherboard. Make sure that the heatsink is fully seated.
7. Use the correct type of onboard CMOS battery as recommended by the manufacturer. Check to verify that it still supplies approximately 3 VDC. If it does not, replace it with a new one. **Warning:** To avoid possible explosion, do not install the battery upside down.
8. Verify that all jumpers are set to their default positions.
9. Check that the power supplies' input voltage operate at 100-120 V or 180-240 V.
10. Turn the power switch on and off to test the system

No Video

1. If the power is on but you have no video, remove all the add-on cards and cables.
2. As you try to power up the system, note any beep codes.

System Boot Failure

If the system does not display Power-On-Self-Test (POST) or does not respond after the power is turned on, check the following:

Turn on the system with only one DIMM module installed. If the system boots, check for bad DIMM modules or slots by following the Memory Errors Troubleshooting procedure below.

Memory Errors

1. Make sure that the DIMM modules are properly and fully installed.
2. Confirm that you are using the correct memory. Also, it is recommended that you use the same memory type and speed for all DIMMs in the system. See [Section 3.5](#) for memory details.
3. Check for bad DIMM modules or slots by swapping modules between slots and noting the results.
4. Check the power supply voltage 115 V/230 V switch.

Losing the System Setup Configuration

- Always replace power supplies with the exact same model that came with the system. A poor quality power supply may cause the system to lose the CMOS setup configuration.
- The battery on your motherboard may be old. Check to verify that it still supplies approximately 3 VDC. If it does not, replace it with a new one.
- If the above steps do not fix the setup configuration problem, contact your vendor for repairs.

When the System Becomes Unstable

If the system becomes unstable during or after OS installation, check the following:

1. CPU/BIOS support: Make sure that your CPU is supported and that you have the latest BIOS installed in your system.
2. Memory support: Make sure that the memory modules are supported by testing the modules using memtest86 or a similar utility.

Note: Refer to the product page on our website at <http://www.supermicro.com> for memory and CPU support and updates.

3. Storage drive support: Make sure that all storage drives work properly. Replace the bad drives with good ones.
4. System cooling: Check the system cooling to make sure that all heatsink fans and CPU/system fans, etc., work properly. Check the hardware monitoring settings in the BMC to make sure that the CPU and system temperatures are within the normal range. Also check the front panel Overheat LED and make sure that it is not on.
5. Adequate power supply: Make sure that the power supply provides adequate power to the system. Make sure that all power connectors are connected. Please refer to our website for more information on the minimum power requirements.
6. Proper software support: Make sure that the correct drivers are used.

If the system becomes unstable before or during OS installation, check the following:

1. Source of installation: Make sure that the devices used for installation are working properly, including boot devices such as a CD.
2. Cable connection: Check to make sure that all cables are connected and working properly.
3. Using the minimum configuration for troubleshooting: Remove all unnecessary components (starting with add-on cards first), and use the minimum configuration (but with a CPU and a memory module installed) to identify the trouble areas. Refer to the steps listed in Section A above for proper troubleshooting procedures.
4. Identifying bad components by isolating them: If necessary, remove a component in question from the chassis, and test it in isolation to make sure that it works properly. Replace a bad component with a good one.
5. Check and change one component at a time instead of changing several items at the same time. This will help isolate and identify the problem.
6. To find out if a component is good, swap this component with a new one to see if the system will work properly. If so, then the old component is bad. You can also install the component in question in another system. If the new system works, the component is good and the old system has problems.

7.4 Crash Dump Using BMC

In the event of a processor internal error (IERR) that crashes your system, you may want to provide information to support staff. You can download a crash dump of status information using BMC.

Check the BMC Error Log

1. Access the BMC web interface.
2. Click the **Server Health** tab, then **Event Log** to verify an IERR error.

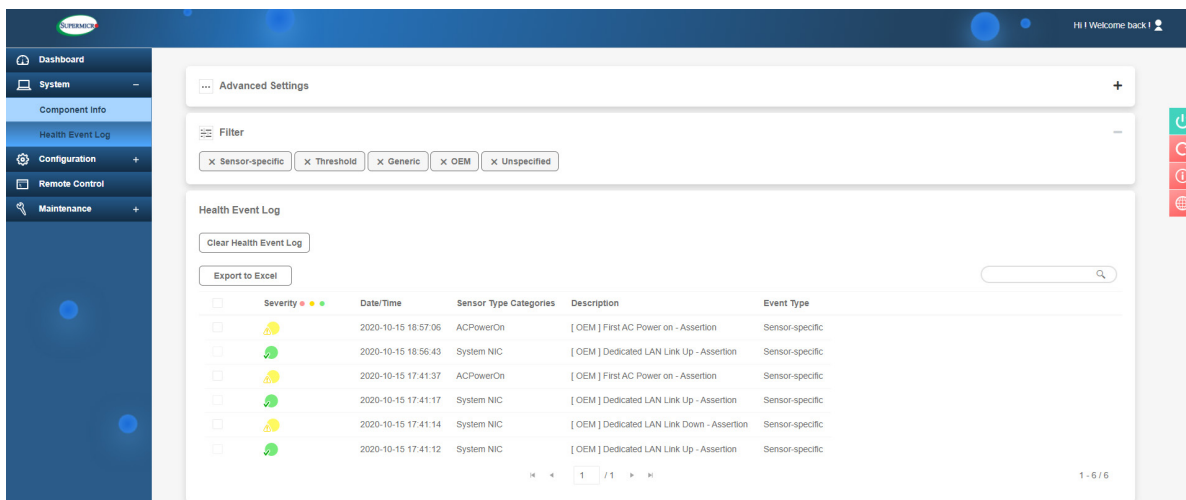

Figure 7-3. BMC Event Log

In the event of an IERR, the BMC executes a crash dump. You must download the crash dump and save it.

7.5 CMOS Clear

JBT1 is used to clear CMOS, which will also clear any passwords. Instead of pins, this jumper consists of contact pads to prevent accidentally clearing the contents of CMOS.

To Clear CMOS

1. First [power down](#) the system completely.
2. [Remove the cover](#) of the chassis to access the motherboard.
3. [Remove the onboard battery](#) from the motherboard.
4. Short the CMOS pads with a metal object such as a small screwdriver for at least four seconds.
5. Remove the screwdriver or shorting device.
6. Replace the cover, reconnect the power cords and power on the system.



Notes: Clearing CMOS will also clear all passwords.

Do not use the PW_ON connector to clear CMOS.

7.6 BMC Reset

The BMC can be reset using the UID button.

- Reset – Press and hold the button. After six seconds, the LED blinks at 2 Hz. The BMC resets and the reset duration is approximately 250 ms. Then the BMC starts to boot.
- Restore factory default configuration – Hold the button for twelve seconds. The LED blinks at 4 Hz while defaults are configured. **Note:** All BMC settings including username and password will be removed except the FRU and network settings.

Firmware update – When the BMC firmware is being updated, the UID LED blinks at 10 Hz.

BMC Reset Options		
Event	UID LED	BMC Heartbeat LED
Reset	Blue, Blinks at 2 Hz	Green, solid
Restore Defaults	Blue, Blinks at 4 Hz	Off
Update	Blue, Blinks at 10 Hz	

7.7 Where to Get Replacement Components

If you need replacement parts for your system, to ensure the highest level of professional service and technical support, purchase exclusively from our Supermicro Authorized Distributors/System Integrators/Resellers. A list can be found at: <http://www.supermicro.com>. Click the "Where to Buy" tab.

7.8 Reporting an Issue

Technical Support Procedures

Before contacting Technical Support, please take the following steps. If your system was purchased through a distributor or reseller, please contact them for troubleshooting services. They have the best knowledge of your specific system configuration.

1. Please review the [Troubleshooting Procedures](#) in this manual and [Frequently Asked Questions](#) on our website before contacting Technical Support.
2. BIOS upgrades can be downloaded from our website. **Note:** Not all BIOS can be flashed depending on the modifications to the boot block code.
3. If you still cannot resolve the problem, include the following information when contacting us for technical support:
 - System, motherboard, and chassis model numbers and PCB revision number
 - BIOS release date/version (this can be seen on the initial display when your system first boots up)
 - System configuration

An example of a Technical Support form is posted on our [website](#). Distributors: For immediate assistance, please have your account number ready when contacting our technical support department by email.

Returning Merchandise for Service

A receipt or copy of your invoice marked with the date of purchase is required before any warranty service will be rendered. You can obtain service by calling your vendor for a Returned Merchandise Authorization (RMA) number. When returning to the manufacturer, the RMA number should be prominently displayed on the outside of the shipping carton, and mailed prepaid or hand-carried. Shipping and handling charges will be applied for all orders that must be mailed when service is complete.

For faster service, RMA authorizations may be requested online:

[\(http:// www. supermicro. com/ support/rma/\)](http://www.supermicro.com/support/rma/)

Whenever possible, repack the chassis in the original Supermicro carton, using the original packaging material. If these are no longer available, be sure to pack the chassis securely, using packaging material to surround the chassis so that it does not shift within the carton and become damaged during shipping.

This warranty only covers normal consumer use and does not cover damages incurred in shipping or from failure due to the alteration, misuse, abuse or improper maintenance of products.

During the warranty period, contact your distributor first for any product problems.

Vendor Support Filing System

For issues related to Intel, use the Intel IPS filing system:

<https://www.intel.com/content/www/us/en/design/support/ips/training/welcome.html>

For issues related to Red Hat Enterprise Linux, since it is a subscription based OS, contact your account representative.

7.9 Feedback

Supermicro values your feedback as we strive to improve our customer experience in all facets of our business. Please email us at techwriterteam@supermicro.com to provide feedback on our manuals.

Appendix A

Standardized Warning Statements for AC Systems

About Standardized Warning Statements

The following statements are industry standard warnings, provided to warn the user of situations which have the potential for bodily injury. Should you have questions or experience difficulty, contact Supermicro's Technical Support department for assistance. Only certified technicians should attempt to install or configure components.

Read this appendix in its entirety before installing or configuring components in the Supermicro chassis.

These warnings may also be found on our website at http://www.supermicro.com/about/policies/safety_information.cfm.

Warning Definition



Warning! This warning symbol means danger. You are in a situation that could cause bodily injury. Before you work on any equipment, be aware of the hazards involved with electrical circuitry and be familiar with standard practices for preventing accidents.

警告の定義

この警告サインは危険を意味します。

人身事故につながる可能性がありますので、いずれの機器でも動作させる前に、電気回路に含まれる危険性に注意して、標準的な事故防止策に精通して下さい。

此警告符号代表危險。

您正处于可能受到严重伤害的工作环境中。在您使用设备开始工作之前，必须充分意识到触电的危险，并熟练掌握防止事故发生的标准工作程序。请根据每项警告结尾的声明号码找到此设备的安全性警告说明的翻译文本。

此警告符號代表危險。

您正處於可能身體可能會受損傷的工作環境中。在您使用任何設備之前，請注意觸電的危險，並且要熟悉預防事故發生的標準工作程序。請依照每一注意事項後的號碼找到相關的翻譯說明內容。

Warnung

WICHTIGE SICHERHEITSHINWEISE

Dieses Warnsymbol bedeutet Gefahr. Sie befinden sich in einer Situation, die zu Verletzungen führen kann. Machen Sie sich vor der Arbeit mit Geräten mit den Gefahren elektrischer Schaltungen und den üblichen Verfahren zur Vorbeugung vor Unfällen vertraut. Suchen Sie mit der am Ende jeder Warnung angegebenen Anweisungsnummer nach der jeweiligen Übersetzung in den übersetzten Sicherheitshinweisen, die zusammen mit diesem Gerät ausgeliefert wurden.

BEWAHREN SIE DIESE HINWEISE GUT AUF.

INSTRUCCIONES IMPORTANTES DE SEGURIDAD

Este símbolo de aviso indica peligro. Existe riesgo para su integridad física. Antes de manipular cualquier equipo, considere los riesgos de la corriente eléctrica y familiarícese con los procedimientos estándar de prevención de accidentes. Al final de cada advertencia encontrará el número que le ayudará a encontrar el texto traducido en el apartado de traducciones que acompaña a este dispositivo.

GUARDE ESTAS INSTRUCCIONES.

IMPORTANTES INFORMATIONS DE SÉCURITÉ

Ce symbole d'avertissement indique un danger. Vous vous trouvez dans une situation pouvant entraîner des blessures ou des dommages corporels. Avant de travailler sur un équipement, soyez conscient des dangers liés aux circuits électriques et familiarisez-vous avec les procédures couramment utilisées pour éviter les accidents. Pour prendre connaissance des traductions des avertissements figurant dans les consignes de sécurité traduites qui accompagnent cet appareil, référez-vous au numéro de l'instruction situé à la fin de chaque avertissement.

CONSERVEZ CES INFORMATIONS.

תקנון הזהרות אזהרה

הזהרות הבאות הן אזהרות על פי תקני התעשייה, על מנת להזהיר את המשתמש מפני חבלה פיזית אפשרית. במידה ויש שאלות או היתקלות בבעיה כלשהי, יש ליצור קשר עם מחלקת תמיכה טכנית של סופרמיקרו. טכנאים מוסמכים בלבד רשאים להתקין או להגדיר את הרכיבים. יש לקרוא את הנספח במלואו לפני התקנת או הגדרת הרכיבים במארזי סופרמיקרו.

اَكْ ف حالة وُكِي اَي تتسبب ف اصابة جسدهُ هذا الزهز عْ خطر! تحذُرُ .
 قبل اَي تعول على اَي هعدات، كي على علن بالوخاطز ال اَجوة عي الذوائر
 الكهزبائِة
 وكي على دراةُ بالووارسات النقاىِة لو عْ وقع اَي حادث
 استخدم رقن الب اى الو صُص ف هاةُ كل تحذُرُ للعشر تزجوتها

안전을 위한 주의사항

경고!

이 경고 기호는 위험이 있음을 알려 줍니다. 작업자의 신체에 부상을 야기 할 수 있는 상태에 있게 됩니다. 모든 장비에 대한 작업을 수행하기 전에 전기회로와 관련된 위험요소들을 확인하시고 사전에 사고를 방지할 수 있도록 표준 작업절차를 준수해 주시기 바랍니다.

해당 번역문을 찾기 위해 각 경고의 마지막 부분에 제공된 경고문 번호를 참조하십시오

BELANGRIJKE VEILIGHEIDSINSTRUCTIES

Dit waarschuwings symbool betekent gevaar. U verkeert in een situatie die lichamelijk letsel kan veroorzaken. Voordat u aan enige apparatuur gaat werken, dient u zich bewust te zijn van de bij een elektrische installatie betrokken risico's en dient u op de hoogte te zijn van de standaard procedures om ongelukken te voorkomen. Gebruik de nummers aan het eind van elke waarschuwing om deze te herleiden naar de desbetreffende locatie.

BEWAAR DEZE INSTRUCTIES

Installation Instructions



Warning! Read the installation instructions before connecting the system to the power source.

設置手順書

システムを電源に接続する前に、設置手順書をお読み下さい。

警告

将此系统连接电源前,请先阅读安装说明。

警告

將系統與電源連接前，請先閱讀安裝說明。

Warnung

Vor dem Anschließen des Systems an die Stromquelle die Installationsanweisungen lesen.

¡Advertencia!

Lea las instrucciones de instalación antes de conectar el sistema a la red de alimentación.

Attention

Avant de brancher le système sur la source d'alimentation, consulter les directives d'installation.

יש לקרוא את הוראות התקנה לפני חיבור המערכת למקור מתח.

اقر إرشادات التركيب قبل توصيل النظام إلى مصدر للطاقة

시스템을 전원에 연결하기 전에 설치 안내를 읽어주십시오.

Waarschuwing

Raadpleeg de installatie-instructies voordat u het systeem op de voedingsbron aansluit.

Circuit Breaker

Warning! This product relies on the building's installation for short-circuit (overcurrent) protection. Ensure that the protective device is rated not greater than: 250 V, 20 A.

サーキット・ブレーカー

この製品は、短絡(過電流)保護装置がある建物での設置を前提としています。

保護装置の定格が250 V、20 Aを超えないことを確認下さい。

警告

此产品的短路(过载电流)保护由建筑物的供电系统提供,确保短路保护设备的额定电流不大于250V,20A。

警告

此產品的短路(過載電流)保護由建築物的供電系統提供,確保短路保護設備的額定電流不大於250V,20A。

Warnung

Dieses Produkt ist darauf angewiesen, dass im Gebäude ein Kurzschluss- bzw. Überstromschutz installiert ist. Stellen Sie sicher, dass der Nennwert der Schutzvorrichtung nicht mehr als: 250 V, 20 A beträgt.

¡Advertencia!

Este equipo utiliza el sistema de protección contra cortocircuitos (o sobrecorrientes) del edificio. Asegúrese de que el dispositivo de protección no sea superior a: 250 V, 20 A.

Attention

Pour ce qui est de la protection contre les courts-circuits (surtension), ce produit dépend de l'installation électrique du local. Vérifiez que le courant nominal du dispositif de protection n'est pas supérieur à :250 V, 20 A.

מוצר זה מסתמך על הגנה המותקנת במבנים למניעת קצר חשמלי. יש לוודא כי המכשיר המגן מפני הקצר החשמלי הוא לא יותר מ-250VDC, 20A

هذا المنتج يعتمد على معدات الحماية مه الدوائر القصيرة التي تم تثبيتها في المبنى
تأكد من أن تقييم الجهاز الوقائي ليس أكثر من : 20A, 250V

경고!

이 제품은 전원의 단락(과전류)방지에 대해서 전적으로 건물의 관련 설비에 의존합니다. 보호장치의 정격이 반드시 250V(볼트), 20A(암페어)를 초과하지 않도록 해야 합니다.

Waarschuwing

Dit product is afhankelijk van de kortsluitbeveiliging (overspanning) van uw elektrische installatie. Controleer of het beveiligde apparaat niet groter gedimensioneerd is dan 250V, 20A.

Power Disconnection Warning



Warning! The system must be disconnected from all sources of power and the power cord removed from the power supply module(s) before accessing the chassis interior to install or remove system components (except for hot-swap components).



電源切断の警告

システムコンポーネントの取り付けまたは取り外しのために、シャーシ内部にアクセスするには、システムの電源はすべてのソースから切断され、電源コードは電源モジュールから取り外す必要があります。

警告

在你打开机箱并安装或移除内部器件前,必须将系统完全断电,并移除电源线

警告

在您打開機殼安裝或移除內部元件前，必須將系統完全斷電，並移除電源線

Warnung

Das System muss von allen Quellen der Energie und vom Netzanschlusskabel getrennt sein, das von den Spg.Versorgungsteilmodulen entfernt wird, bevor es auf den Chassisinnenraum zurückgreift, um Systemsbestandteile anzubringen oder zu entfernen.

¡Advertencia!

El sistema debe ser disconnected de todas las fuentes de energía y del cable eléctrico quitado de los módulos de fuente de alimentación antes de tener acceso el interior del chasis para instalar o para quitar componentes de sistema.

Attention

Le système doit être débranché de toutes les sources de puissance ainsi que de son cordon d'alimentation secteur avant d'accéder à l'intérieur du chassis pour installer ou enlever des composants de système.

אזהרה מפני ניתוק חשמלי

אזהרה!

יש לנתק את המערכת מכל מקורות החשמל ויש להסיר את כבל החשמלי מהספק לפני גישה לחלק הפנימי של המארז לצורך התקנת או הסרת רכיבים.

يجب فصل انظاؤ من جميع مصادر انطاقت وإزانت سهك انكهرباء من وحدة امداد انطاقت قېم

انصل إلى امناطق انداخييت نههيكم نشييج أو إزانت مكناث الجهاز

경고!

시스템에 부품들을 장착하거나 제거하기 위해서는 새시 내부에 접근하기 전에 반드시 전원 공급장치로부터 연결되어있는 모든 전원과 전기코드를 분리해주어야 합니다.

Waarschuwing

Voordat u toegang neemt tot het binnenwerk van de behuizing voor het installeren of verwijderen van systeem onderdelen, dient u alle spanningsbronnen en alle stroomkabels aangesloten op de voeding(en) van de behuizing te verwijderen

Equipment Installation



Warning! Only authorized personnel and qualified service persons should be allowed to install, replace, or service this equipment.

機器の設置

トレーニングを受け認定された人だけがこの装置の設置、交換、またはサービスを許可されています。

警告

只有经过培训且具有资格的人员才能进行此设备的安装、更换和维修。

警告

只有經過受訓且具資格人員才可安裝、更換與維修此設備。

Warnung

Nur autorisiertes Personal und qualifizierte Servicetechniker dürfen dieses Gerät installieren, austauschen oder warten..

¡Advertencia!

Sólo el personal autorizado y el personal de servicio calificado deben poder instalar, reemplazar o dar servicio a este equipo.

Attention

Seul le personnel autorisé et le personnel de maintenance qualifié doivent être autorisés à installer, remplacer ou entretenir cet équipement..

אזהרה!

יש לאפשר רק צוות מורשה ואנשי שירות מוסמכים להתקין, להחליף או לטפל בציוד זה.

ينبغي السماح فقط للموظفين المعتمدين وأفراد الخدمة المؤهلين بتركيب هذا الجهاز أو استبداله أو صيانته.

경고!

승인된 직원과 자격을 갖춘 서비스 담당자만이 이 장비를 설치, 교체 또는 서비스할 수 있습니다.

Waarschuwing

Alleen geautoriseerd personeel en gekwalificeerd onderhoudspersoneel mag deze apparatuur installeren, vervangen of onderhouden..

Restricted Area

Warning! This unit is intended for installation in restricted access areas. A restricted access area can be accessed only through the use of a special tool, lock and key, or other means of security. (This warning does not apply to workstations).

アクセス制限区域

このユニットは、アクセス制限区域に設置されることを想定しています。

アクセス制限区域は、特別なツール、鍵と錠前、その他のセキュリティの手段を用いてのみ出入りが可能です。

警告

此部件应安装在限制进出的场所，限制进出的场所指只能通过使用特殊工具、锁和钥匙或其它安全手段进出的场所。

警告

此裝置僅限安裝於進出管制區域，進出管制區域係指僅能以特殊工具、鎖頭及鑰匙或其他安全方式才能進入的區域。

Warnung

Diese Einheit ist zur Installation in Bereichen mit beschränktem Zutritt vorgesehen. Der Zutritt zu derartigen Bereichen ist nur mit einem Spezialwerkzeug, Schloss und Schlüssel oder einer sonstigen Sicherheitsvorkehrung möglich.

¡Advertencia!

Esta unidad ha sido diseñada para instalación en áreas de acceso restringido. Sólo puede obtenerse acceso a una de estas áreas mediante la utilización de una herramienta especial, cerradura con llave u otro medio de seguridad.

Attention

Cet appareil doit être installée dans des zones d'accès réservés. L'accès à une zone d'accès réservé n'est possible qu'en utilisant un outil spécial, un mécanisme de verrouillage et une clé, ou tout autre moyen de sécurité.

אזור עם גישה מוגבלת

אזהרה!

יש להתקין את היחידה באזורים שיש בהם הגבלת גישה. הגישה ניתנת בעזרת 'מפתח, מנעול וכד' (כלי אבטחה בלבד).

تخصيص هذه انحدة نترك بُها ف مناطق محظورة تم .

،ممكن اننصل إن منطقت محظورة فقط من خلال استخذاو أداة خاصت أو أ وس هُت أخري نلالأمما ققم ومفتاح

경고!

이 장치는 접근이 제한된 구역에 설치하도록 되어있습니다. 특수도구, 잠금 장치 및 키, 또는 기타 보안 수단을 통해서만 접근 제한 구역에 들어갈 수 있습니다.

Waarschuwing

Dit apparaat is bedoeld voor installatie in gebieden met een beperkte toegang. Toegang tot dergelijke gebieden kunnen alleen verkregen worden door gebruik te maken van speciaal gereedschap, slot en sleutel of andere veiligheidsmaatregelen.

Battery Handling



Warning! There is the danger of explosion if the battery is replaced incorrectly. Replace the battery only with the same or equivalent type recommended by the manufacturer. Dispose of used batteries according to the manufacturer's instructions

電池の取り扱い

電池交換が正しく行われなかった場合、破裂の危険性があります。交換する電池はメーカーが推奨する型、または同等のものを使用下さい。使用済電池は製造元の指示に従って処分して下さい。

警告

電池更換不當會有爆炸危險。請只使用同類電池或制造商推荐的功能相当的電池更換原有電池。請按制造商的說明處理廢舊電池。

警告

電池更換不當會有爆炸危險。請使用製造商建議之相同或功能相當的電池更換原有電池。請按照製造商的說明指示處理廢棄舊電池。

Warnung

Bei Einsetzen einer falschen Batterie besteht Explosionsgefahr. Ersetzen Sie die Batterie nur durch den gleichen oder vom Hersteller empfohlenen Batterietyp. Entsorgen Sie die benutzten Batterien nach den Anweisungen des Herstellers.

Attention

Danger d'explosion si la pile n'est pas remplacée correctement. Ne la remplacer que par une pile de type semblable ou équivalent, recommandée par le fabricant. Jeter les piles usagées conformément aux instructions du fabricant.

¡Advertencia!

Existe peligro de explosión si la batería se reemplaza de manera incorrecta. Reemplazar la batería exclusivamente con el mismo tipo o el equivalente recomendado por el fabricante. Desechar las baterías gastadas según las instrucciones del fabricante.

אזהרה!

קיימת סכנת פיצוץ של הסוללה במידה והוחלפה בדרך לא תקינה. יש להחליף את הסוללה בסוג התואם מחברת יצרן מומלצת. סילוק הסוללות המשומשות יש לבצע לפי הוראות היצרן.

هناك خطر من انفجار في حالة اسبدال البطارية بطريقة غير صحيحة فعلى
اسبدال البطارية
فقط بنفس النوع أو ما يعادلها مما أوصت به الشركة المصنعة
جخلص من البطاريات المسحومة وفقا لعمليات الشركة الصانعة

경고!

배터리가 올바르게 교체되지 않으면 폭발의 위험이 있습니다. 기존 배터리와 동일하거나 제조사에서 권장하는 동등한 종류의 배터리로만 교체해야 합니다. 제조사의 안내에 따라 사용된 배터리를 처리하여 주십시오.

Waarschuwing

Er is ontplofingsgevaar indien de batterij verkeerd vervangen wordt. Vervang de batterij slechts met hetzelfde of een equivalent type die door de fabrikant aanbevolen wordt. Gebruikte batterijen dienen overeenkomstig fabrieksvoorschriften afgevoerd te worden.

Redundant Power Supplies



Warning! This unit might have more than one power supply connection. All connections must be removed to de-energize the unit.

冗長電源装置

このユニットは複数の電源装置が接続されている場合があります。

ユニットの電源を切るためには、すべての接続を取り外さなければなりません。

警告

此部件连接的电源可能不止一个，必须将所有电源断开才能停止给该部件供电。

警告

此装置连接的电源可能不只一个，必须切断所有电源才能停止对该装置的供电。

Warnung

Dieses Gerät kann mehr als eine Stromzufuhr haben. Um sicherzustellen, dass der Einheit kein Strom zugeführt wird, müssen alle Verbindungen entfernt werden.

¡Advertencia!

Puede que esta unidad tenga más de una conexión para fuentes de alimentación. Para cortar por completo el suministro de energía, deben desconectarse todas las conexiones.

Attention

Cette unité peut avoir plus d'une connexion d'alimentation. Pour supprimer toute tension et tout courant électrique de l'unité, toutes les connexions d'alimentation doivent être débranchées.

אם קיים יותר מספק אחד

אזהרה!

ליחידה יש יותר מחיבור אחד של ספק. יש להסיר את כל החיבורים על מנת לרוקן את היחידה.

قد يكون لهذا الجهاز عدة اتصالات بوحدات امداد الطاقة .

يجب إزالة كافة الاتصالات لعسل الوحدة عن الكهرباء

경고!

이 장치에는 한 개 이상의 전원 공급 단자가 연결되어 있을 수 있습니다. 이 장치에 전원을 차단하기 위해서는 모든 연결 단자를 제거해야만 합니다.

Waarschuwing

Deze eenheid kan meer dan één stroomtoevoeraansluiting bevatten. Alle aansluitingen dienen verwijderd te worden om het apparaat stroomloos te maken.

Backplane Voltage



Warning! Hazardous voltage or energy is present on the backplane when the system is operating. Use caution when servicing.

バックプレーンの電圧

システムの稼働中は危険な電圧または電力が、バックプレーン上にかかっています。

修理する際には注意ください。

警告

当系统正在进行时，背板上有很危险的电压或能量，进行维修时务必小心。

警告

當系統正在進行時，背板上危險的電壓或能量，進行維修時務必小心。

Warnung

Wenn das System in Betrieb ist, treten auf der Rückwandplatine gefährliche Spannungen oder Energien auf. Vorsicht bei der Wartung.

¡Advertencia!

Cuando el sistema está en funcionamiento, el voltaje del plano trasero es peligroso. Tenga cuidado cuando lo revise.

Attention

Lorsque le système est en fonctionnement, des tensions électriques circulent sur le fond de panier. Prendre des précautions lors de la maintenance.

מתח בפנל האחורי

אזהרה!

קיימת סכנת מתח בפנל האחורי בזמן תפעול המערכת. יש להיזהר במהלך העבודה.

هناك خطر من التيار الكهربائي أو الطاقة المتجددة على اللوحة
عندما يكون النظام يعمل كه حذرا عند خدمة هذا الجهاز

경고!

시스템이 동작 중일 때 후면판 (Backplane)에는 위험한 전압이나 에너지가 발생 합니다.
서비스 작업 시 주의하십시오.

Waarschuwing

Een gevaarlijke spanning of energie is aanwezig op de backplane wanneer het systeem in gebruik is. Voorzichtigheid is geboden tijdens het onderhoud.

Comply with Local and National Electrical Codes



Warning! Installation of the equipment must comply with local and national electrical codes.

地方および国の電気規格に準拠

機器の取り付けはその地方および国の電気規格に準拠する必要があります。

警告

设备安装必须符合本地与本国电气法规。

警告

設備安裝必須符合本地與本國電氣法規。

Warnung

Die Installation der Geräte muss den Sicherheitsstandards entsprechen.

¡Advertencia!

La instalación del equipo debe cumplir con las normas de electricidad locales y nacionales.

Attention

L'équipement doit être installé conformément aux normes électriques nationales et locales.

תיאום חוקי החשמל הארצי
אזהרה!
התקנת הציוד חייבת להיות תואמת לחוקי החשמל המקומיים והארציים.

تركيب المعدات الكهربائية يجب أن يمتثل للقوايه المحلية والبطية المتعلقة
بالكهرباء

경고!

현 지역 및 국가의 전기 규정에 따라 장비를 설치해야 합니다.

Waarschuwing

Bij installatie van de apparatuur moet worden voldaan aan de lokale en nationale elektriciteitsvoorschriften.

Product Disposal



Warning! Ultimate disposal of this product should be handled according to all national laws and regulations.

製品の廃棄

この製品を廃棄処分する場合、国の関係する全ての法律・条例に従い処理する必要があります。

警告

本产品的废弃处理应根据所有国家的法律和规章进行。

警告

本產品的廢棄處理應根據所有國家的法律和規章進行。

Warnung

Die Entsorgung dieses Produkts sollte gemäß allen Bestimmungen und Gesetzen des Landes erfolgen.

¡Advertencia!

Al deshacerse por completo de este producto debe seguir todas las leyes y reglamentos nacionales.

Attention

La mise au rebut ou le recyclage de ce produit sont généralement soumis à des lois et/ou directives de respect de l'environnement. Renseignez-vous auprès de l'organisme compétent.

סילוק המוצר

אזהרה!

סילוק סופי של מוצר זה חייב להיות בהתאם להנחיות וחוקי המדינה.

التخلص النهائي من هذا المنتج ينبغي التعامل معه وفقا لجميع القوانين واللوائح الوطنية عند

경고!

이 제품은 해당 국가의 관련 법규 및 규정에 따라 폐기되어야 합니다.

Waarschuwing

De uiteindelijke verwijdering van dit product dient te geschieden in overeenstemming met alle nationale wetten en reglementen.

Fan Warning



Warning! Hazardous moving parts. Keep away from moving fan blades. The fans might still be turning when you remove the fan assembly from the chassis. Keep fingers, screwdrivers, and other objects away from the openings in the fan assembly's housing.

ファンの警告

警告!回転部品に注意。運転中は回転部(羽根)に触れないでください。シャーシから冷却ファン装置を取り外した際、ファンがまだ回転している可能性があります。ファンの開口部に、指、ドライバー、およびその他のものを近づけないで下さい。

警告!

警告! 危險的可移動性零件。請務必與轉動的风扇叶片保持距離。當您從機架移除風扇裝置，風扇可能仍在轉動。小心不要將手指、螺絲起子和其他物品太靠近風扇

警告

危險的可移動性零件。請務必與轉動的风扇叶片保持距離。當您從機架移除風扇裝置，風扇可能仍在轉動。小心不要將手指、螺絲起子和其他物品太靠近風扇。

Warnung

Gefährlich Bewegende Teile. Von den bewegenden Lüfterblätter fern halten. Die Lüfter drehen sich u. U. noch, wenn die Lüfterbaugruppe aus dem Chassis genommen wird. Halten Sie Finger, Schraubendreher und andere Gegenstände von den Öffnungen des Lüftergehäuses entfernt.

¡Advertencia!

Riesgo de piezas móviles. Mantener alejado de las aspas del ventilador. Los ventiladores podran dar vuelta cuando usted quite el montaje del ventilador del chasis. Mantenga los dedos, los destornilladores y todos los objetos lejos de las aberturas del ventilador

Attention

Pieces mobiles dangereuses. Se tenir a l'écart des lames du ventilateur Il est possible que les ventilateurs soient toujours en rotation lorsque vous retirerez le bloc ventilateur du châssis. Prenez garde à ce que doigts, tournevis et autres objets soient éloignés du logement du bloc ventilateur.

אזהרה!

חלקים נעים מסוכנים. התרחק מלהבי המאוורר בפעולה כאשר מסירים את חלקי המאוורר מהמארז, יתכן והמאווררים עדיין עובדים. יש להרחיק למרחק בטוח את האצבעות וכלי עבודה שונים מהפתחים בתוך המאוורר

تحذير! أجزاء متحركة خطيرة. ابتعد عن شفرات المروحة المتحركة. من الممكن أن المراوح لا تزال تدور عند إزالة كتلة المروحة من الهيكل يجب إبقاء الأصابع ومفكات البراغي وغيرها من الأشياء بعيدا عن الفتحات في كتلة المروحة

경고!

움직이는 위험한 부품. 회전하는 송풍 날개에 접근하지 마세요. 새시로부터 팬 조립품을 제거할 때 팬은 여전히 회전하고 있을 수 있습니다. 팬 조립품 외관의 열려있는 부분들로부터 손가락 및 스크류드라이버, 다른 물체들이 가까이 하지 않도록 배치해 주십시오.

Waarschuwing

Gevaarlijk bewegende onderdelen. Houd voldoende afstand tot de bewegende ventilatorbladen. Het is mogelijk dat de ventilator nog draait tijdens het verwijderen van het ventilatorsamenstel uit het chassis. Houd uw vingers, schroevendraaiers en eventuele andere voorwerpen uit de buurt van de openingen in de ventilatorbehuizing.

Power Cable and AC Adapter



Warning! When installing the product, use the provided or designated connection cables, power cables and AC adaptors. Using any other cables and adaptors could cause a malfunction or a fire. Electrical Appliance and Material Safety Law prohibits the use of UL or CSA -certified cables (that have UL/CSA shown on the cord) for any other electrical devices than products designated by Supermicro only.

電源コードとACアダプター

製品を設置する場合、提供または指定および購入された接続ケーブル、電源コードとACアダプターを該当する地域の条例や安全基準に適合するコードサイズやプラグと共に使用下さい。他のケーブルやアダプタを使用すると故障や火災の原因になることがあります。

電気用品安全法は、ULまたはCSA認定のケーブル(UL/CSAマークがコードに表記)を Supermicro が指定する製品以外に使用することを禁止しています。

警告

安装此产品时,请使用本身提供的或指定的或采购的连接线,电源线和电源适配器。包含遵照当地法规和安全要求的合规的电源线尺寸和插头。使用其它线材或适配器可能会引起故障或火灾。除了Supermicro所指定的产品,电气用品和材料安全法律规定禁止使用未经UL或CSA认证的线材。(线材上会显示UL/CSA符号)。

警告

安裝此產品時,請使用本身提供的或指定的或採購的連接線,電源線和電源適配器。包含遵照當地法規和安全要求的合規的電源線尺寸和插頭。使用其它線材或適配器可能會引起故障或火災。除了Supermicro所指定的產品,電氣用品和材料安全法律規定禁止使用未經UL或CSA認證的線材。(線材上會顯示UL/CSA符號)。

Warnung

Nutzen Sie beim Installieren des Produkts ausschließlich die von uns zur Verfügung gestellten Verbindungskabeln, Stromkabeln und/oder Adapter, die Ihre örtlichen Sicherheitsstandards einhalten. Der Gebrauch von anderen Kabeln und Adapter können Fehlfunktionen oder Feuer verursachen. Die Richtlinien untersagen das Nutzen von UL oder CAS zertifizierten Kabeln (mit UL/CSA gekennzeichnet), an Geräten oder Produkten die nicht mit Supermicro gekennzeichnet sind.

¡Advertencia!

Cuando instale el producto, utilice la conexión provista o designada o procure cables, Cables de alimentación y adaptadores de CA que cumplan con los códigos locales y los requisitos de seguridad, incluyendo el tamaño adecuado del cable y el enchufe. El uso de otros cables y adaptadores podría causar un mal funcionamiento o un incendio. La Ley de Seguridad de Aparatos Eléctricos y de Materiales prohíbe El uso de cables certificados por UL o CSA (que tienen el certificado UL / CSA en el código) para cualquier otros dispositivos eléctricos que los productos designados únicamente por Supermicro.

Attention

Lors de l'installation du produit, utilisez les cables de connection fournis ou désigné ou achetez des cables, cables de puissance et adaptateurs respectant les normes locales et les conditions de securite y compris les tailles de cables et les prises electriques appropriées. L'utilisation d'autres cables et adaptateurs peut provoquer un dysfonctionnement ou un incendie. Appareils électroménagers et la Loi sur la Sécurité Matériel interdit l'utilisation de câbles certifiés- UL ou CSA (qui ont UL ou CSA indiqué sur le code) pour tous les autres appareils électriques sauf les produits désignés par Supermicro seulement.

AC ימאתמו מיילמשח מילבכ

!הרהזא

ךרוצל ומאתוה וא ושכרנ רשא AC מימאתמו מיקפס, מילבכב שמתשהל שי, רצומה תא מיניקתמ רשאכ לכב שומיש . עקתהו לבכה לש הנוכח הדימ ללוכ, תוימוקמה תוחיטבה תושירדל ומאתוה רשאו, הנקתהה למשחה ירישכמב שומישה יקוחל מאתהב. ילמשח רצק וא הלקתל מורגל לולע, רחא גוסמ מאתמ וא לבכ לש דוק מהילע עיפומ רשאכ) UL-ב או CSA-ב-ב מיכמומה מילבכב שמתשהל רוסיא מייק, תוחיטבה יקוחו דבלב Supermicro י"ע מאתוה רשא רצומב קר אלא, רחא ילמשח רצומ לכ רובע (UL/CSA)

תאלבאלא אארשב מץ וא אדדחמלא וא ארפוטמלא תאליטוטלא מאדחטסאב מץ, אגתנמלא בייקרת דנע לכלז יפ אמב אילחמלא אמאלסלא תאבלטתמו נינאווקב מאזתלאלא אמ דדרתמלא ראיטלא תאלוחמו אילברמלא קיירח וא לטע יפ בבסטטי דץ ירשא תאלוחמו תאלבאלא יא מאדחטסא. מילסלא סבאלאו לטומוא מץ ח CSA וא UL לביק נמ אדמאמלא תאלבאלא מאדחטסא תאדמלא אילברמלא אזהאלל אמאלסלא נונאק רזחי Supermicro לביק נמ אדדחמלא אילברמלא תאגתנמלא ריג ירשא תאדמא יא אמ (UL/CSA) אמאלע למחתיטלאו

전원 케이블 및 AC 어댑터

경고! 제품을 설치할 때 현지 코드 및 적절한 굵기의 코드와 플러그를 포함한 안전 요구 사항을 준수하여 제공되거나 지정된 연결 혹은 구매 케이블, 전원 케이블 및 AC 어댑터를 사용하십시오.

다른 케이블이나 어댑터를 사용하면 오작동이나 화재가 발생할 수 있습니다. 전기 용품 안전법은 UL 또는 CSA 인증 케이블 (코드에 UL / CSA가 표시된 케이블)을 Supermicro 가 지정한 제품 이외의 전기 장치에 사용하는 것을 금지합니다.

Stroomkabel en AC-Adapter

Waarschuwing! Bij het aansluiten van het Product uitsluitend gebruik maken van de geleverde Kabels of een andere geschikte aan te schaffen Aansluitmethode, deze moet altijd voldoen aan de lokale voorschriften en veiligheidsnormen, inclusief de juiste kabeldikte en stekker. Het gebruik van niet geschikte Kabels en/of Adapters kan een storing of brand veroorzaken. Wetgeving voor Elektrische apparatuur en Materiaalveiligheid verbied het gebruik van UL of CSA -gecertificeerde Kabels (met UL/CSA in de code) voor elke andere toepassing dan de door Supermicro hiervoor beoogde Producten.

Appendix B

System Specifications

Processors

Dual 5th/4th Gen Intel Xeon scalable with 4 UPI (16 GT/s max) and a total of 160 Gen5 PCIe lanes in a Socket E (LGA-4677)

Chipset

Intel® C741

BIOS

AMI 32 MB SPI Flash EEPROM

Memory

32 DIMM slots, 1 DPC ECC DDR5 RDIMM/LRDIMM for up to 5600 MT/s

Storage Drives

24 hot-swap E3.S (7.5 mm) NVMe drive bays

Two PCIe 3.0 (NVMe or SATA3 hybrid slots) with support of M-Key 2280 and 22110

PCI Expansion Slots

Two PCIe 5.0 x8 slots (full-height, full-length)

One PCIe 5.0 x16 slot (full-height, full-length; x8 when slots 1 and 2 are used)

One PCIe 5.0 x16 slot (full-height, full-length; x8 when slots 3 and 4 are used)

Two PCIe 5.0 AIOM slots

Input/Output

Four USB 3.0 ports (two front, two rear)

One rear RJ45 dedicated 1GbE IPMI

One rear VGA port

Motherboard

X13DSF-A: 12" (L) x 13" (W) (305 mm x 330 mm)

Chassis

CSE-126ES2-R2K08P: 4U; (WxHxD) 17.2 x 1.7 x 30.4 in. (437 x 43 x 772 mm)

System Cooling

Eight heavy duty 8-cm fans with optimal fan speed control

One air shroud

Power Supply

PWS-2K08A-1R: Two 2000 W redundant modules, 80Plus Titanium Level

AC Input

1000 W: 100-127 Vac / 50-60 Hz

1800 W: 200-220 Vac / 50-60 Hz

1980 W: 220-230V ac / 50-60 Hz

2000 W: 220-240 Vac / 50-60 Hz (for UL only)

2000 W: 230-240 Vac / 50-60 Hz

2000 W: 230-240 Vdc / 50-60 Hz (for China only)

+12 V

Max: 83 A / Min: 0 A (100 Vac-127 Vac)

Max: 150 A / Min: 0 A (200 Vac-220 Vac)

Max: 165 A / Min: 0 A (220 Vac-230 Vac)

Max: 166 A / Min: 0 A (230 Vac-240 Vac)

12 V SB

Max: 3.5 A

Operating Environment

Operating Temperature: 10° to 35° C (50° to 95° F)
 Non-operating Temperature: -40° to 60° C (-40° to 140° F)
 Operating Relative Humidity: 8% to 90% (non-condensing)
 Non-operating Relative Humidity: 5% to 95% (non-condensing)

Regulatory Compliance

FCC, ICES, CE, UKCA, VCCI, RCM, NRTL, CB

Applied Directives, Standards

EMC/EMI: 2014/30/EU (EMC Directive) CLASS A
 Electromagnetic Compatibility Regulations 2016
 FCC Part 15
 ICES-003
 VCCI-CISPR 32
 AS/NZS CISPR 32
 BS/EN 55032
 BS/EN 55035
 CISPR 32
 CISPR 24/CISPR 35
 BS/EN 61000-3-2
 BS/EN 61000-3-3
 BS/EN 61000-4-2
 BS/EN 61000-4-3
 BS/EN 61000-4-4
 BS/EN 61000-4-5
 BS/EN 61000-4-6
 BS/EN 61000-4-11

Product Safety: 2014/35/EU (LVD Directive)
 UL/CSA 62368-1 (USA and Canada)
 Electrical Equipment (Safety) Regulations 2016
 IEC/BS/EN 62368-1

Environment:

2011/65/EU (RoHS Directive)
 EC 1907/2006 (REACH)
 2012/19/EU (WEEE Directive)

Warning! This product can expose you to chemicals including lead, known to the State of California to cause cancer and birth defects or other reproductive harm. For more information, go to www.P65Warnings.ca.gov.

Perchlorate Warning

California Best Management Practices Regulations for Perchlorate Materials: This Perchlorate warning applies only to products containing CR (Manganese Dioxide) Lithium coin cells. Perchlorate Material-special handling may apply. See www.dtsc.ca.gov/hazardouswaste/perchlorate

この装置は、クラスA機器です。この装置を住宅環境で使用すると電波妨害を引き起こすことがあります。この場合には使用者が適切な対策を講ずるよう要求されることがあります。

VCCI - A